

# Automated Planning and Acting

## Deterministic Models

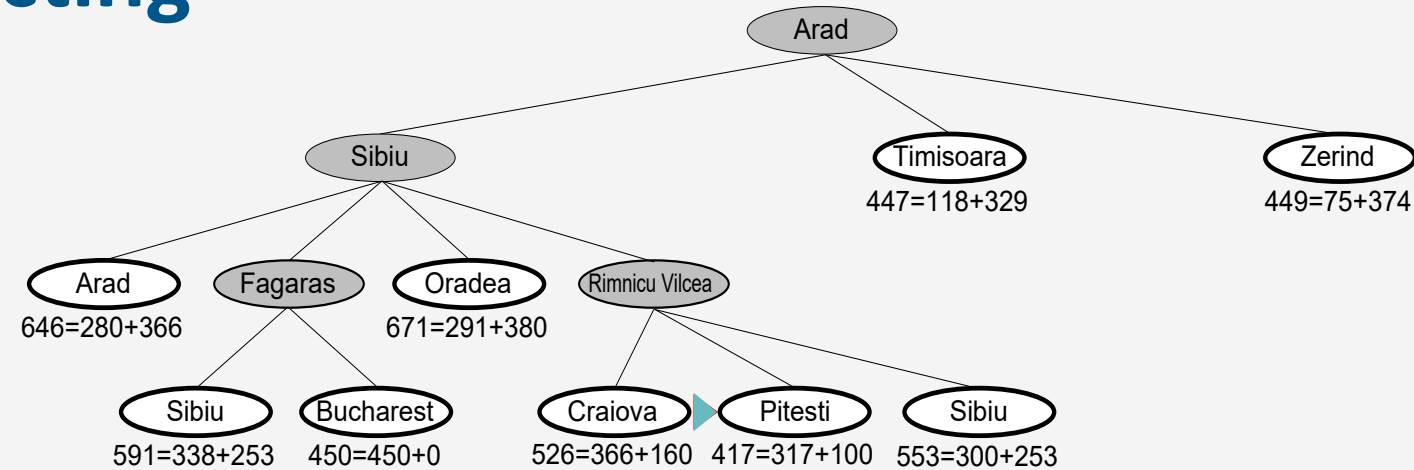

# Content: Planning and Acting

## 1. With **Deterministic** Models

- a. State-variable representation
- b. Forward State-Space Search
- c. Heuristic Functions
- d. Backward Search
- e. Plan-Space Search

## 2. With **Temporal** Models

## 3. With **Nondeterministic** Models

## 4. With **Probabilistic** Models

## 5. By **Decision Making**

- A. Foundations
- B. Extensions
- C. Structure

## 6. With **Human-awareness**

# Outline per the Book

## 2.1 *State-variable representation*

- State = {values of variables}; action = changes to those values

## 2.2 *Forward state-space search*

- Start at initial state, look for sequence of actions that achieve goal

## 2.3 *Heuristic functions*

- How to guide a forward state-space search

## 2.6 *Incorporating planning into an actor*

- Online lookahead, unexpected events

## 2.4 *Backward search*

- Start at goal state, go backwards toward initial state

## 2.5 *Plan-space search*

- Start with incomplete plan for getting from initial state to goal state, make transformations to fix flaws in the plan

## Motivation

- How to model a complex environment?
  - Generally, need simplifying **assumptions**
- **Classical planning**
  - **Finite, static world**: Change occurs only when the actor causes it
  - **No concurrent actions, no explicit time**: Just a sequence of states and actions  $\langle s_0, a_1, s_1, a_2, s_2, \dots \rangle$
  - **Determinism, no uncertainty**: Can predict exactly what each action will do
    - No accidents, no “chance” outcomes
- Avoids a lot of complications
  - But most real-world environments do not satisfy the assumptions
- Errors in prediction
  - OK if they are infrequent and do not have severe consequences

## Domain Model

- **State-transition system** (or *classical planning domain*)
  - $\Sigma = (S, A, \gamma, cost)$ ; *cost* is optional
    - $S$  - finite set of **states** that the system may be in
    - $A$  - finite set of **actions**: things the actor can do
    - $\gamma : S \times A \rightarrow S$  - **prediction function** (or *state-transition function*)
      - **partial** function:  $\gamma(s, a)$  is not defined unless  $a$  is **applicable** in  $s$
      - $\text{dom}(a) = \{s \in S \mid \gamma(s, a) \text{ is defined}\} = \{s \in S \mid a \text{ applicable in } s\}$  (domain)
      - $\text{ran}(a) = \{\gamma(s, a) \mid s \in \text{dom}(a)\}$  (range)
    - $cost : S \times A \rightarrow \mathbb{R}^+$  -or-  $cost : A \rightarrow \mathbb{R}^+$ 
      - Could be monetary cost, time required, something else
      - Often omitted from  $\Sigma$ ; default is  $cost(a) = 1$

## Domain Model

- Given a state-transition system  $\Sigma = (S, A, \gamma, cost)$
- **Classical planning problem:**  $P = (\Sigma, s_0, S_g)$ 
  - $\Sigma$  planning domain
  - $s_0 \in S$  initial state
  - $S_g \subseteq S$  set of goal states
- **Solution** for  $P$ 
  - A sequence of actions called **plan** that will produce a state in  $S_g$

## Representing $\Sigma$

- If  $S$  and  $A$  are small enough
  - Give each state and action a name
  - For each  $s$  and  $a$ , store  $\gamma(s, a)$  in a lookup table
- In larger domains, do not represent all states explicitly
  - Language for describing properties of states
  - Language for describing how each action changes those properties
  - Start with initial state, use actions to produce other states

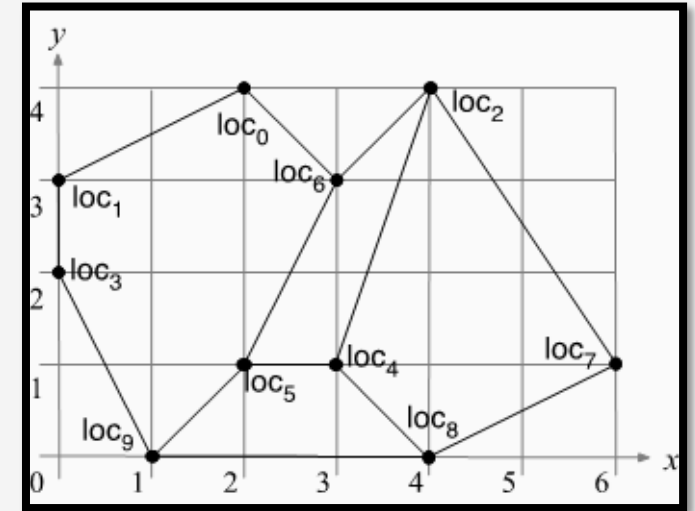

## Domain-specific Representation

- Made to order for a specific environment
- State: arbitrary data structure
- Action: (head, preconditions, effects, cost)
  - **head**: name and parameter list
    - Get actions by instantiating the parameters
  - **preconditions**:
    - Computational tests to predict whether an action can be performed in a state  $s$
    - Should be necessary/sufficient for the action to run without error
  - **effects**:
    - Procedures that modify the current state
  - **cost**: procedure that returns a number
    - Can be omitted, default is  $\text{cost} \equiv 1$

## Example

- Drilling holes in a metal workpiece
  - A state
    - Geometric model of the workpiece, information about its location and orientation
    - Capabilities and status of drilling machine and drill bit
  - Several actions
    - Putting the workpiece onto the drilling machine
    - Clamping it
    - Loading a drill bit
    - Drilling (next slide)

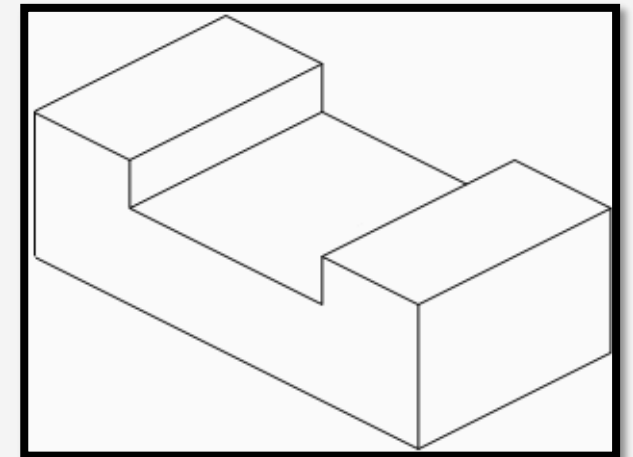

# Drilling

- Name and parameters:
  - drill-hole(*machine, drill-bit, workpiece, geometry, machining-tolerances*)
- Preconditions
  - Can the drilling machine and drill bit produce a hole having the desired geometry and machining tolerances?
  - Is the drill bit installed? Is the workpiece clamped onto the drilling platform? Etc.
- Effects
  - Geometric model of new workpiece geometry, annotated with tolerances
- Cost
  - Estimate of time or monetary cost

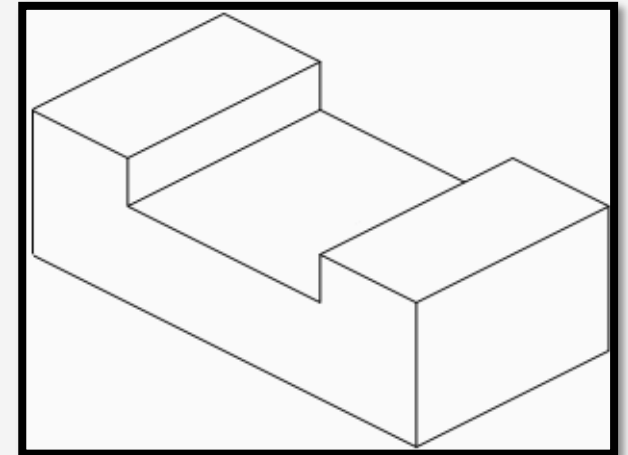

## Discussion

- Advantage of domain-specific representation:
  - Can choose whatever works best for that particular domain
- Disadvantage:
  - For each new domain, need new representation and deliberation algorithms
- Alternative: **domain-independent** representation
  - Try to create a “standard format” that can be used for many different planning domains
  - Deliberation algorithms that work for anything in this format
- **State-variable** representation
  - Simple formats for describing states and actions
  - Limited representational capability but easy to compute, easy to reason about
  - Domain-independent search algorithms and heuristic functions that can be used in all state-variable planning problems

## State-Variable Representation

- $E$  : environment that we want to represent
- $B$  : set of objects
  - Names for objects in  $E$ , mathematical constants, ...
  - Only needs to include objects that matter at current level of abstraction
- Example (slightly different from the book)
  - $B = Robots \cup Containers \cup Locs \cup \{nil\}$ 
    - $Robots = \{r1, r2\}$
    - $Containers = \{c1, c2\}$
    - $Locs = \{d1, d2, d3\}$
- Can omit lots of details
  - E.g., physical characteristics of robots, containers, loading docks, roads

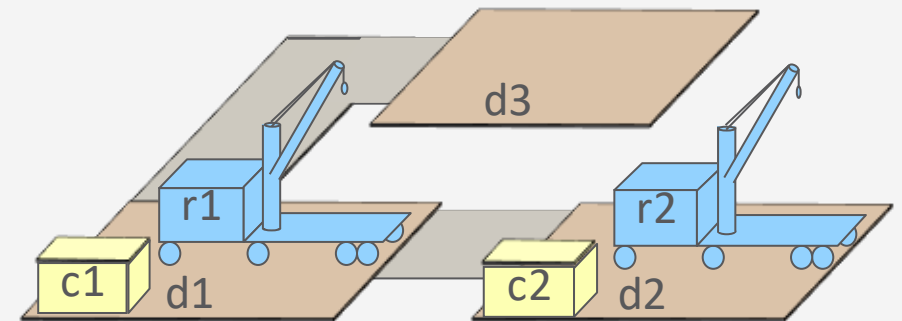

## Properties of Objects

- Define ways to represent properties of objects
  - Two kinds of properties: **rigid** and **varying**
  - Sets of rigid properties  $R$  and varying properties  $X$
- **Rigid** property:  $n$ -ary relation  $r$  over  $B$ 
  - Stays the same in every state
  - Representation
    - As a mathematical relation
      - $adj = \{(d1, d2), (d2, d1), (d1, d3), (d3, d1)\}$
    - As a set of ground atoms
      - $adj(d1, d2), adj(d2, d1), adj(d1, d3), adj(d3, d1)$

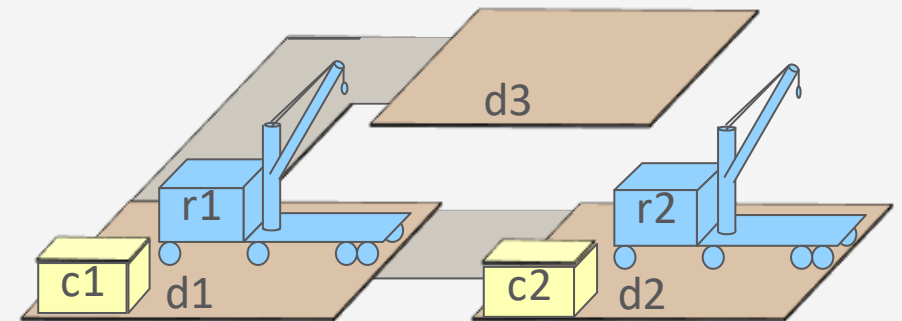

## Varying Properties

- **Varying** property  $x$  (or *fluent*)
  - May differ in different states
  - Represent it using a **state variable** to assign a value to
- Set of state variables  $X = \{loc(r1), loc(r2), loc(c1), loc(c2), cargo(r1), cargo(r2)\}$
- Each state variable  $x \in X$  has a **range**  
$$ran(x) = \{\text{all values that can be assigned to } x\}$$
  - $ran(loc(r1)) = ran(loc(r2)) = Locs$
  - $ran(loc(c1)) = ran(loc(c2)) = Robots \cup Locs$
  - $ran(cargo(r1)) = ran(cargo(r2)) = Containers \cup \{nil\}$ 
    - $cargo(r)$ : robot  $r$  has a cargo

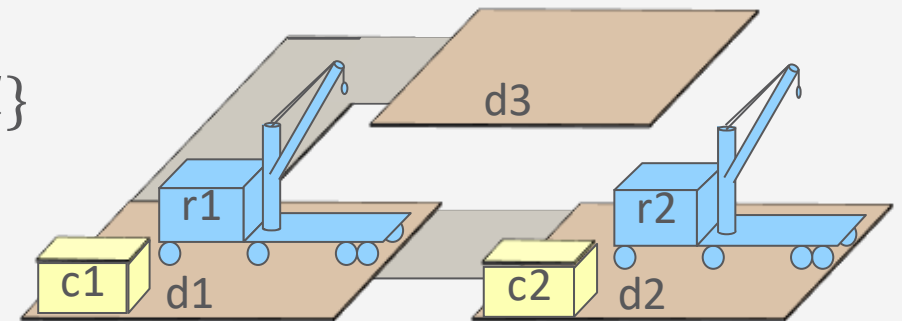

## States as Functions

- Represent each state as a **variable-assignment function**

- Function that maps each  $x \in X$  to a value in  $\text{ran}(x)$

$$\begin{aligned}
 s_1(\text{loc}(r1)) &= d1, & s_1(\text{loc}(r2)) &= d2, \\
 s_1(\text{cargo}(r1)) &= \text{nil}, & s_1(\text{cargo}(r2)) &= \text{nil}, \\
 s_1(\text{loc}(c1)) &= d1, & s_1(\text{loc}(c2)) &= d2
 \end{aligned}$$

- Mathematically, a function is a set of ordered pairs

$$s_1 = \{(\text{loc}(r1), d1), (\text{cargo}(r1), \text{nil}), (\text{loc}(c1), d1), \dots\}$$

- Write it as a set of **ground positive literals** (or *ground atoms*):

$$\begin{aligned}
 s_1 = \{ & \text{loc}(r1) = d1, \text{ cargo}(r1) = \text{nil}, \\
 & \text{loc}(r2) = d2, \text{ cargo}(r2) = \text{nil}, \\
 & \text{loc}(c1) = d1, \text{ loc}(c2) = d2 \}
 \end{aligned}$$

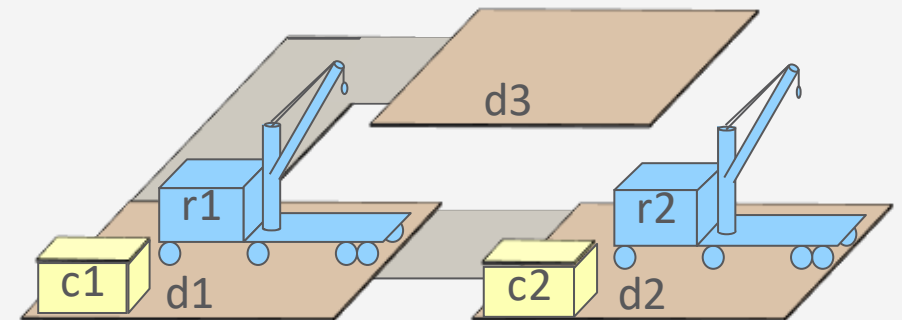

## States as Functions

- Let  $s$  be a variable-assignment function
  - $s$  is a state only if it has a sensible meaning in our intended environment  $E$
  - **Interpretation**: a function  $I$ 
    - Maps each  $b \in B$  to an object in  $E$
    - Maps each  $r \in R$  to a rigid property in  $E$
    - Maps each  $x \in X$  to a varying property in  $E$
- **State**: a variable-assignment function  $s$  such that  $I(s)$  can occur in  $E$ 
  - **State space**  $S = \{\text{all possible states}\}$

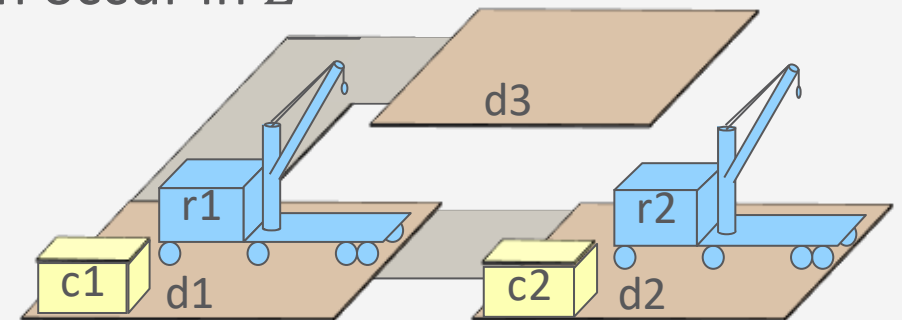

## Action Templates

- Action **template**  $\alpha$ : a parameterized action representing a set of actions  
 $\alpha = (\text{head}(\alpha), \text{pre}(\alpha), \text{eff}(\alpha), \text{cost}(\alpha))$ 
  - $\text{head}(\alpha)$ : **name, parameters**
    - Each parameter has a range  $\subseteq B$
  - $\text{pre}(\alpha)$ : **precondition** literals
    - $\text{rel}(t_1, \dots, t_k), \text{var}(t_1, \dots, t_k) = t_0$
    - $\neg \text{rel}(t_1, \dots, t_k), \neg \text{var}(t_1, \dots, t_k) = t_0$
    - Each  $t_i$  is a parameter or an element of  $B$
  - $\text{eff}(\alpha)$ : **effect** literals  $\text{var}(t_1, \dots, t_k) \leftarrow t_0$
  - $\text{cost}(\alpha)$ : a number; optional, default = 1

- Example  $\alpha$ :
  - head:  $\text{move}(r, l, m)$ 
    - pre:  $\text{loc}(r) = l, \text{adj}(l, m)$
    - eff:  $\text{loc}(r) \leftarrow m$
  - Ranges
    - $\text{ran}(r) = \text{Robots} = \{r1, r2\}$
    - $\text{ran}(l) = \text{ran}(m) = \text{Locs} = \{d1, d2, d3\}$
    - $\text{ran}(c) = \text{Containers} = \{c1, c2\}$

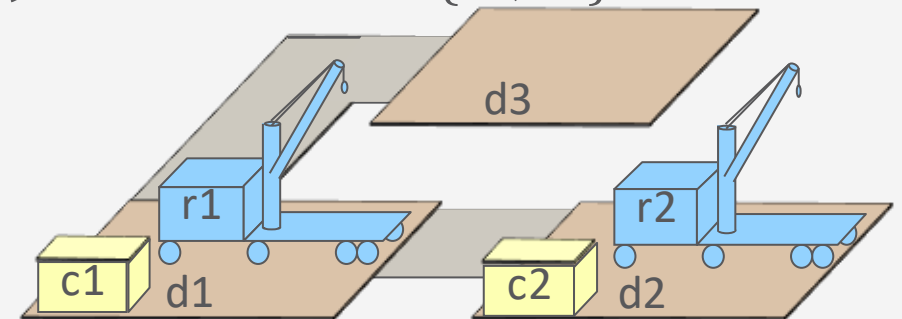

How many move actions exist?

## Actions

- **Action**  $a$ : *ground instance* of an action template  $\alpha$ 
  - Replace each parameter  $t$  occurring in  $\alpha$  with a value from  $\text{ran}(t)$
- Example  $a$ :
  - $\text{move}(r1, d1, d2)$ 
    - pre:  $\text{loc}(r1) = d1, \text{adj}(d1, d2)$
    - eff:  $\text{loc}(r1) \leftarrow d2$

- Example  $\alpha$ :
  - head:  $\text{move}(r, l, m)$ 
    - pre:  $\text{loc}(r) = l, \text{adj}(l, m)$
    - eff:  $\text{loc}(r) \leftarrow m$
  - Ranges
    - $\text{ran}(r) = \text{Robots} = \{r1, r2\}$
    - $\text{ran}(l) = \text{ran}(m) = \text{Locs} = \{d1, d2, d3\}$
    - $\text{ran}(c) = \text{Containers} = \{c1, c2\}$

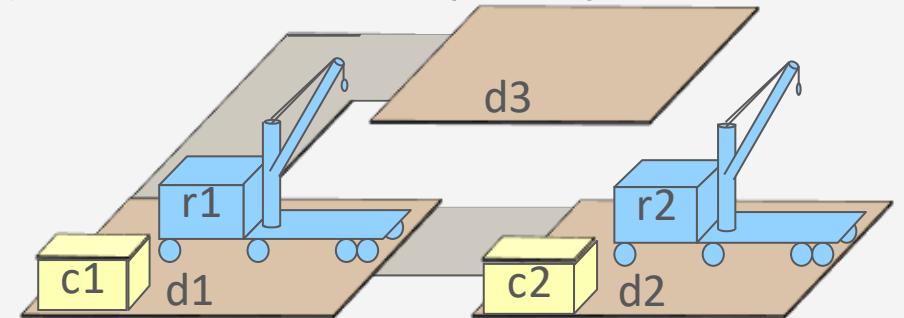

## Action Space

- $\mathcal{A}$  set of action templates
- Action space  $A$ 
  - = {all actions we can get from  $\mathcal{A}$ }
  - = {all ground instances of  $a \in \mathcal{A}$ }

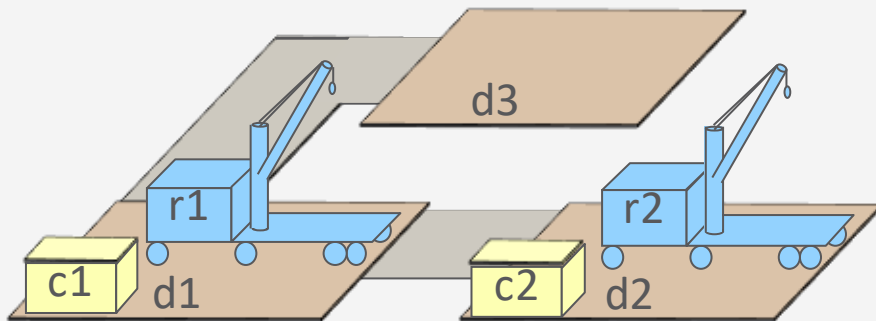

- Example  $\mathcal{A}$ :
  - head:  $move(r, l, m)$ 
    - pre:  $loc(r) = l, adj(l, m)$
    - eff:  $loc(r) \leftarrow m$
  - head:  $take(r, l, c)$ 
    - pre:  $cargo(r) = nil, loc(r) = l, loc(c) = l$
    - eff:  $cargo(r) \leftarrow c, loc(c) \leftarrow r$
  - head:  $put(r, l, c)$ 
    - pre:  $loc(r) = l, loc(c) = r$
    - eff:  $cargo(r) \leftarrow nil, loc(c) \leftarrow l$

# Applicability

- Action  $a$  is **applicable** in state  $s$  if
  - For every positive literal  $l \in pre(\alpha)$ ,  $l$  is in  $s$  or in one of the rigid relations
  - For every negative literal  $\neg l \in pre(\alpha)$ ,  $l$  is not in  $s$  nor in any rigid relations
  - Examples
    - Applicable action in  $s_1$ :  $move(r1, d1, d2)$ 
      - pre:  $loc(r1) = d1, adj(d1, d2)$
      - eff:  $loc(r1) \leftarrow d2$
    - Not applicable action in  $s_1$ :  $move(r1, d2, d1)$ 
      - pre:  $loc(r1) = d2, adj(d2, d1)$
      - eff:  $loc(r1) \leftarrow d1$

How many applicable move actions exist?

Why?

- Example
  - Rigid relation:  $adj = \{(d1, d2), (d2, d1), (d1, d3), (d3, d1)\}$
  - State  $s_1 = \{cargo(r1) = nil, cargo(r2) = nil, loc(r1) = d1, loc(r2) = d2, loc(c1) = d1, loc(c2) = d2\}$
  - Action template  $move(r, l, m)$ 
    - pre:  $loc(r) = l, adj(l, m)$
    - eff:  $loc(r) \leftarrow m$

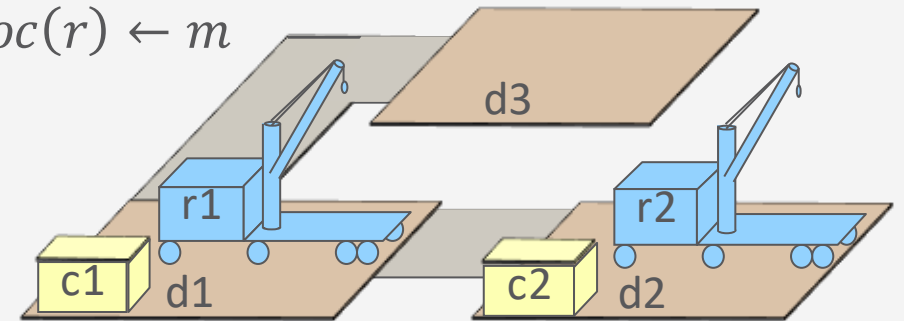

## Computing Prediction Function $\gamma$

- If action  $a$  is **applicable** in state  $s$ , then  $\gamma(s, a)$  is computed as:

$$\{(x, w) \mid \text{eff}(a) \text{ contains the effect } x \leftarrow w\}$$

$$\cup \{(x, w) \in s \mid x \text{ is not the target of any effect in } \text{eff}(a)\}$$

- Example: action  $\text{take}(r2, d2, c2)$  in state  $s_1$ ;  $s_2 = \gamma(s_1, \text{take}(r2, d2, c2))$

- pre:

- $\text{cargo}(r2) = \text{nil}$

- $\text{loc}(r2) = d2$

- $\text{loc}(c2) = d2$

- eff:

- $\text{cargo}(r2) \leftarrow c2$

- $\text{loc}(c2) \leftarrow r2$

$$s_1 = \left\{ \begin{array}{l} \text{cargo}(r1) = \text{nil}, \text{cargo}(r2) = \text{nil}, \\ \text{loc}(r1) = d1, \text{loc}(r2) = d2, \\ \text{loc}(c1) = d1, \text{loc}(c2) = d2 \end{array} \right\}$$

$$s_2 = \left\{ \begin{array}{l} \text{cargo}(r1) = \text{nil}, \text{cargo}(r2) = c2, \\ \text{loc}(r1) = d1, \text{loc}(r2) = d2, \\ \text{loc}(c1) = d1, \text{loc}(c2) = r2 \end{array} \right\}$$

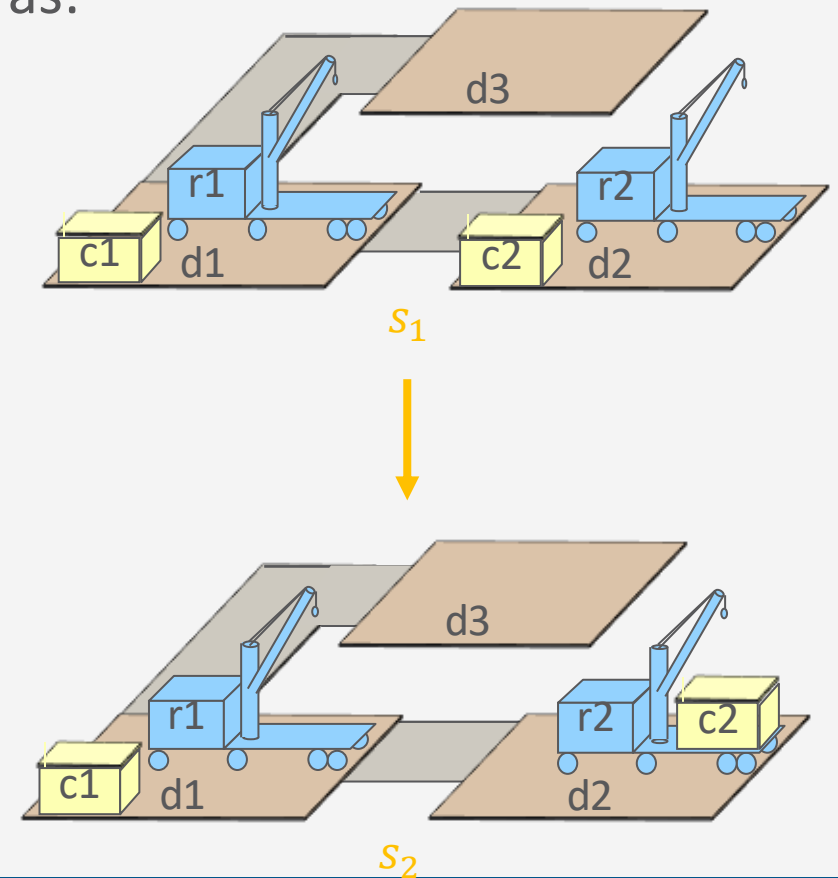

## State-Variable Planning Domain

- Let
  - $B$  = finite set of objects
  - $R$  = finite set of rigid relations over  $B$
  - $X$  = finite set of state variables
    - for every state variable  $x$ ,  $\text{ran}(x) \subseteq B$
  - $S$  = state space over  $X$  = {all variable-assignment functions that have sensible interpretations}
  - $\mathcal{A}$  = finite set of action templates
    - For every parameter  $t$ ,  $\text{ran}(t) \subseteq B$
  - $A$  = {all ground instances of action templates in  $\mathcal{A}$ }
  - $\gamma(s, a) = \{(x, w) \mid \text{eff}(a) \text{ contains } x \leftarrow w\} \cup \{(x, w) \in s \mid x \text{ not target of any effect in } \text{eff}(a)\}$
- Then  $\Sigma = (S, A, \gamma)$  is a **state-variable planning domain**

# Plans

- Plan: sequence of actions  $\pi = \langle a_1, a_2, \dots, a_n \rangle$ 
  - $cost(\pi) = \sum_i cost(a_i)$
  - Length of  $\pi = n$
- $\pi$  is applicable in  $s_0$  if the actions in  $\pi$  can be applied in the order given,
  - i.e., there are states  $s_1, s_2, \dots, s_n$  such that  $\gamma(s_0, a_1) = s_1, \gamma(s_1, a_2) = s_2, \dots, \gamma(s_{n-1}, a_n) = s_n$
  - If so, then define  $\gamma(s_0, \pi) = s_n$
- Example
  - $\pi = \langle move(r1, d3, d1), take(r1, d1, c1), move(r1, d1, d3) \rangle$ 
    - $cost(\pi) = 3$  (default)
  - Applicable in  $s_0 = \{loc(r1) = d3, cargo(r1) = nil, loc(c1) = d1\}$ 
    - $\gamma(s_0, \pi) = \{loc(r1) = d3, cargo(r1) = c1, loc(c1) = r1\}$

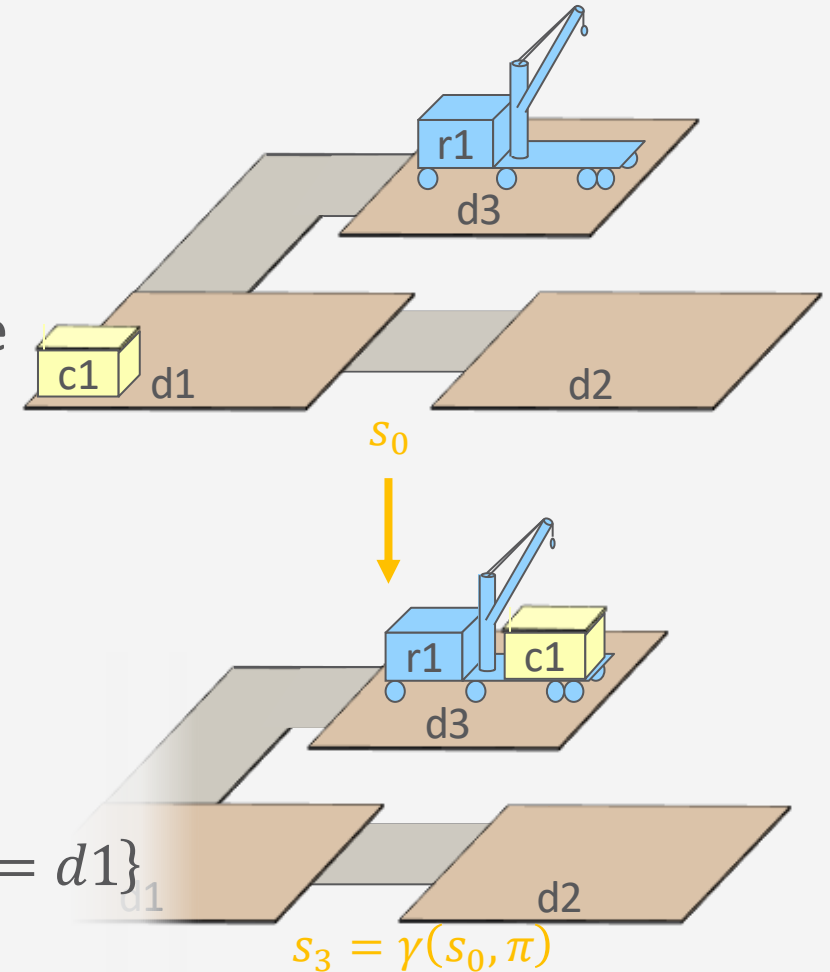

## State Space

- Directed graph
  - Nodes = states of the world
  - Edges:  $\gamma$
- If  $\pi = \langle a_1, a_2, \dots, a_n \rangle$  is applicable in  $s_0$ , it produces a **path**  $\langle s_1, s_2, \dots, s_n \rangle$ 
  - $\gamma(s_0, a_1) = s_1$ ,
  - $\gamma(s_1, a_2) = s_2, \dots$ ,
  - $\gamma(s_{n-1}, a_n) = s_n$

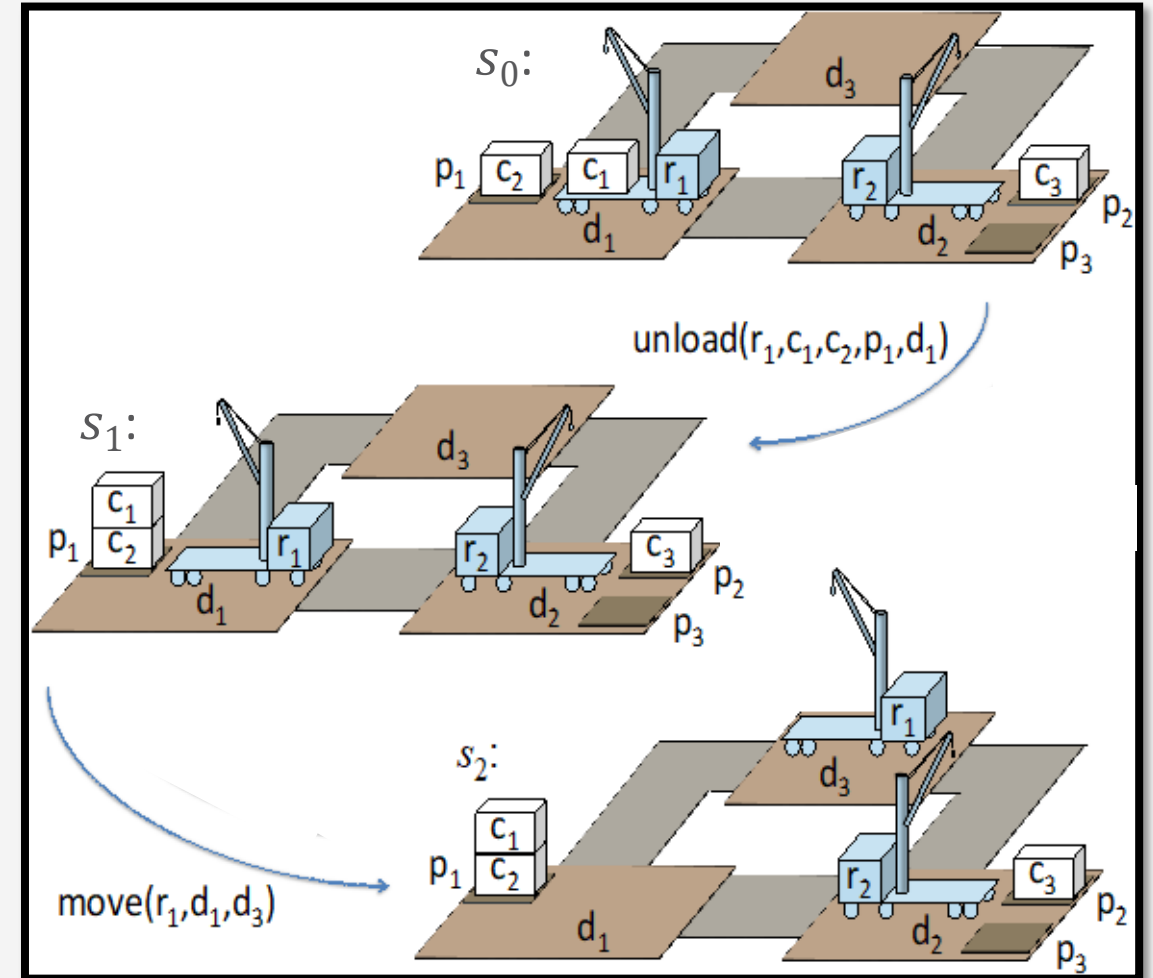

# Planning Problems

- State-variable planning problem

$$P = (\Sigma, s_0, g)$$

- State-variable representation of a classical planning problem
- $\Sigma = (S, A, \gamma)$  state-variable planning domain
- $s_0 \in S$  is the initial state
- $g$  set of ground literals called **goal**
  - $S_g = \{ \text{all states in } S \text{ that satisfy } g \}$   
 $= \{ s \in S \mid s \cup R \text{ contains every positive literal in } g, \text{ and none of the negative literals in } g \}$
- If  $\gamma(s_0, \pi) \in S_g$ , then  $\pi$  is a **solution** for  $P$

How many solutions of length 3 exist?

- Example

- $s_0 = \{ \text{loc}(r1) = d2, \text{cargo}(r1) = \text{nil}, \text{loc}(c1) = d1 \}$
- $adj = \{ (d1, d2), (d2, d1), (d1, d3), (d3, d1) \}$
- $g = \{ \text{cargo}(r1) = c1 \}$
- $\pi = \langle \text{move}(r1, d2, d1), \text{take}(r1, d1, c1) \rangle$

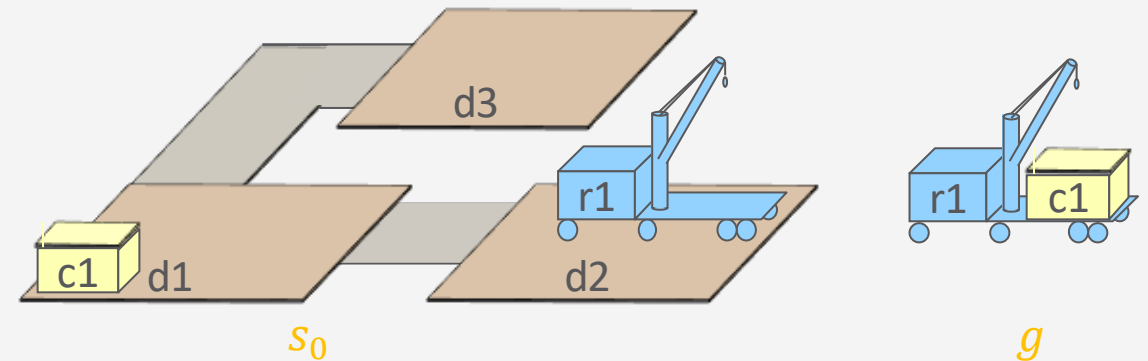

# Classical Representation

- Motivation
  - The field of AI planning started out as automated theorem proving
  - It still uses a lot of that notation
- Classical representation is equivalent to state-variable representation
  - Represents both rigid and varying properties using logical predicates
    - $adj(l, m)$  - location  $l$  is adjacent to location  $m$
    - $loc(r) = l \rightarrow loc(r, l)$  - robot  $r$  is at location  $l$
    - $loc(c) = r \rightarrow loc(c, r)$  - container  $c$  is on robot  $r$
    - $cargo(r) = c \rightarrow loaded(r)$  - robot  $r$  is loaded with a container
- State  $s =$  a set of ground atoms
  - $s_0 = \{adj(d1, d2), adj(d2, d1), adj(d1, d3), adj(d3, d1), loc(c1, d1), loc(r1, d2)\}$

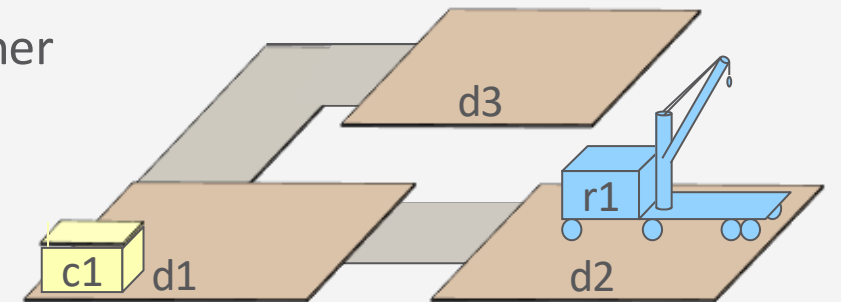

## Classical Representation

- Equivalent expressive power
  - Each can be converted to the other in linear time and space
    - Each logical atom  $p$  is translated into a Boolean state variable  $x_p$  with parameter list  $(t_1, \dots, t_k)$ 
      - Positive literals  $p(t_1, \dots, t_k)$  become  $x_p(t_1, \dots, t_k) = 1$
      - Negative literals  $\neg p(t_1, \dots, t_k)$  become  $x_p(t_1, \dots, t_k) = 0$
    - ← Each state variable  $x(t_1, \dots, t_k)$  is translated into a set of logical atoms  $\{p_x(t_1, \dots, t_k, v) \mid v \in \text{ran}(x)\}$ 
      - Planning operator  $\triangleq$  action template (next slide)
- Worst case complexity: EXPSPACE
  - Time needed to solve a classical planning problem may be exponential in the size of the problem description

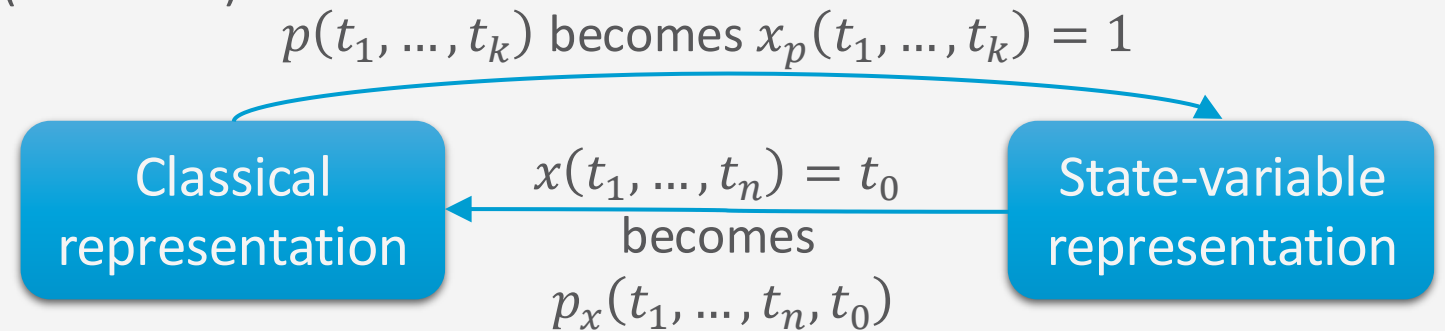

## Classical Planning Operators

- Given action template  
 $\alpha = (\text{head}(\alpha), \text{pre}(\alpha), \text{eff}(\alpha), \text{cost}(\alpha))$
- Planning operator  
 $o = (\text{head}(o), \text{pre}(o), \text{eff}(o))$ 
  - $\text{pre}(o), \text{eff}(o)$  are sets of literals
- May have twice as many effects and parameters as action template
  - From operator to template: same number
- Translation from  $\alpha$  to  $o$ 
  - Precondition  $x(t_1, \dots, t_k) = v$ 
    - $p_x(t_1, \dots, t_k, v)$
  - Precondition  $x(t_1, \dots, t_k) \neq v$ 
    - $\neg p_x(t_1, \dots, t_k, v)$
  - Effect  $x(t_1, \dots, t_k) \leftarrow v'$ 
    - $p_x(t_1, \dots, t_k, v')$
    - If  $p_x(t_1, \dots, t_k, v) \in \text{pre}(o)$  for some  $v$ :
      - Add new effect  $\neg p_x(t_1, \dots, t_k, v)$
    - Otherwise
      - Add new parameter  $u$  to  $\text{head}(o)$
      - Add new precondition  $p_x(t_1, \dots, t_k, u)$
      - Add new effect  $\neg p_x(t_1, \dots, t_k, u)$

## Classical Planning Operators: Example

- Action templates
  - head:  $move(r, l, m)$ 
    - pre:  $loc(r) = l, adj(l, m)$
    - eff:  $loc(r) \leftarrow m$
  - head:  $take(r, l, c)$ 
    - pre:  $cargo(r) = nil, loc(r) = l, loc(c) = l$
    - eff:  $cargo(r) \leftarrow c, loc(c) \leftarrow r$
  - head:  $put(r, l, c)$ 
    - pre:  $loc(r) = l, loc(c) = r$
    - eff:  $cargo(r) \leftarrow nil, loc(c) \leftarrow l$
- Classical planning operators
  - head:  $move(r, l, m)$ 
    - pre:  $loc(r, l), adj(l, m)$
    - eff:  $\neg loc(r, l), loc(r, m)$
  - head:  $take(r, l, c)$ 
    - pre:  $\neg loaded(r), loc(r, l), loc(c, l)$
    - eff:  $loaded(r), loc(c, r), \neg loc(c, l)$
  - head:  $put(r, l, c)$ 
    - pre:  $loc(r, l), loc(c, r)$
    - eff:  $\neg loaded(r), loc(c, l), \neg loc(c, r)$

## PDDL – Planning Domain Definition Language

- Language for defining planning domains and problems
  - LISP-like syntax
- Original version  $\approx$  1996
  - Just classical planning
- Multiple revisions and extensions
  - Different subsets accommodate different kinds of planning
- We will discuss the classical-planning subset
  - Chapter 2 of the PDDL book



## Example Domain

- Classical planning operators
  - $move(r, l, m)$ 
    - pre:  $loc(r, l), adj(l, m)$
    - eff:  $\neg loc(r, l), loc(r, m)$
  - $take(r, l, c)$ 
    - pre:  $\neg loaded(r), loc(r, l), loc(c, l)$
    - eff:  $loaded(r), loc(c, r), \neg loc(c, l)$
  - $put(r, l, c)$ 
    - pre:  $loc(r, l), loc(c, r)$
    - eff:  $\neg loaded(r), loc(c, l), \neg loc(c, r)$

```
(define (domain example-domain-1)
  (requirements :negative-preconditions)
```

```
(:action move
:parameters (?r ?l ?m)
:precondition (and (loc ?r ?l)
                  (adj ?l ?m))
:effect (and (not (loc ?r ?l))
            (loc ?r ?m)))
```

```
(:action take
:parameters (?r ?l ?c)
:precondition (and (loc ?r ?l)
                  (loc ?c ?l)
                  (not (loaded ?r)))
:effect (and (not (loc ?r ?l))
            (loc ?r ?m)))
```

```
(:action put
:parameters (?r ?l ?c)
:precondition (and (loc ?r ?l)
                  (loc ?c ?r))
:effect (and (loc ?c ?l)
            (not (loc ?c ?r))
            (not (loaded ?r))))
```

## Example Problem

- Initial state  $s_0 =$   
 $\{adj(d1, d2), adj(d2, d1),$   
 $adj(d1, d3), adj(d3, d1),$   
 $loc(c1, d1), loc(r1, d2)\}$
- Goal state  $g = \{loc(c1, r1)\}$

```
(define (problem example-problem-1)
  (:domain example-domain-1))
```

```
(:init
  (adj d1 d2)
  (adj d2 d1)
  (adj d1 d3)
  (adj d3 d1)
  (loc c1 d1)
  (loc r1 d2))
```

```
(:goal (loc c1 r1))
```

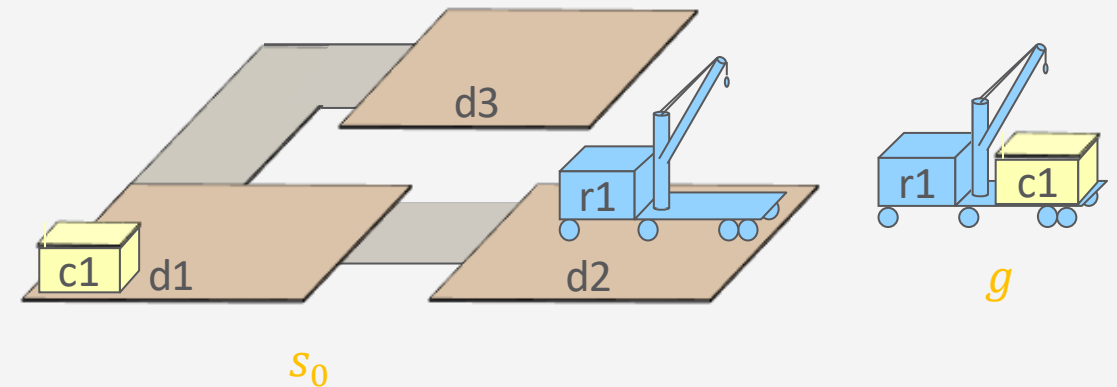

## Example Typed Domain

```
(define (domain example-domain-2)
  (:requirements
    :negative-preconditions
    :typing)

  (:types
    location movable-obj - object
    robot container - movable-obj)

  (:predicates
    (loc ?r - movable-obj
      ?l - location)
    (loaded ?r - robot)
    (adjacent ?l ?m - location)))
```

```
(:action move
:parameters (?r - robot
             ?l ?m - location)
<<as before>>
```

```
(:action take
:parameters (?r - robot
             ?l - location
             ?c - container)
<<as before>>
```

```
(:action put
:parameters (?r - robot
             ?l - location
             ?c - container)
<<as before>>
```

## Example Typed Problem

```
(define (problem example-problem-1)
  (:domain example-domain-1))
(:init
  (adj d1 d2)
  (adj d2 d1)
  (adj d1 d3)
  (adj d3 d1)
  (loc c1 d1)
  (loc r1 d2))
(:goal (loc c1 r1)))
```

```
(define (problem example-problem-2)
  (:domain example-domain-2))
```

```
(:objects
  r1 - robot
  c1 - container
  d1 d2 d3 - location)
```

```
(:init
  (adjacent d1 d2)
  (adjacent d2 d1)
  (adjacent d1 d3)
  (adjacent d3 d1)
  (loc c1 d1)
  (loc r1 d2))
```

```
(:goal (loc c1 r1)))
```

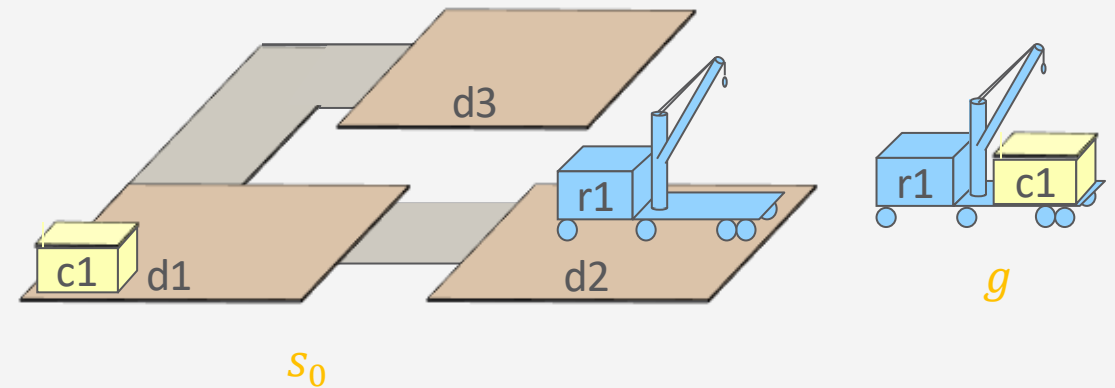

**Deterministic**

## Intermediate Summary

- State-variable representation
  - State-transition systems, classical planning assumptions
  - Classical planning problems, plans, solutions
  - Objects, rigid properties
  - Varying properties, state variables, states as functions
  - Action templates, actions, applicability,  $\gamma$
  - State-variable planning domains, plans, problems, solutions
  - Comparison with classical representation
- Classical fragment of PDDL
  - Planning domains, planning problems
  - untyped, typed

# Outline per the Book

## 2.1 *State-variable representation*

- State = {values of variables}; action = changes to those values

## 2.2 *Forward state-space search*

- Start at initial state, look for sequence of actions that achieve goal

## 2.3 *Heuristic functions*

- How to guide a forward state-space search

## 2.6 *Incorporating planning into an actor*

- Online lookahead, unexpected events

## 2.4 *Backward search*

- Start at goal state, go backwards toward initial state

## 2.5 *Plan-space search*

- Start with incomplete plan for getting from initial state to goal state, make transformations to fix flaws in the plan

# Planning as Search

- Nearly all planning procedures are search procedures
  - Search tree**: the data structure the procedure uses to keep track of which paths it has explored

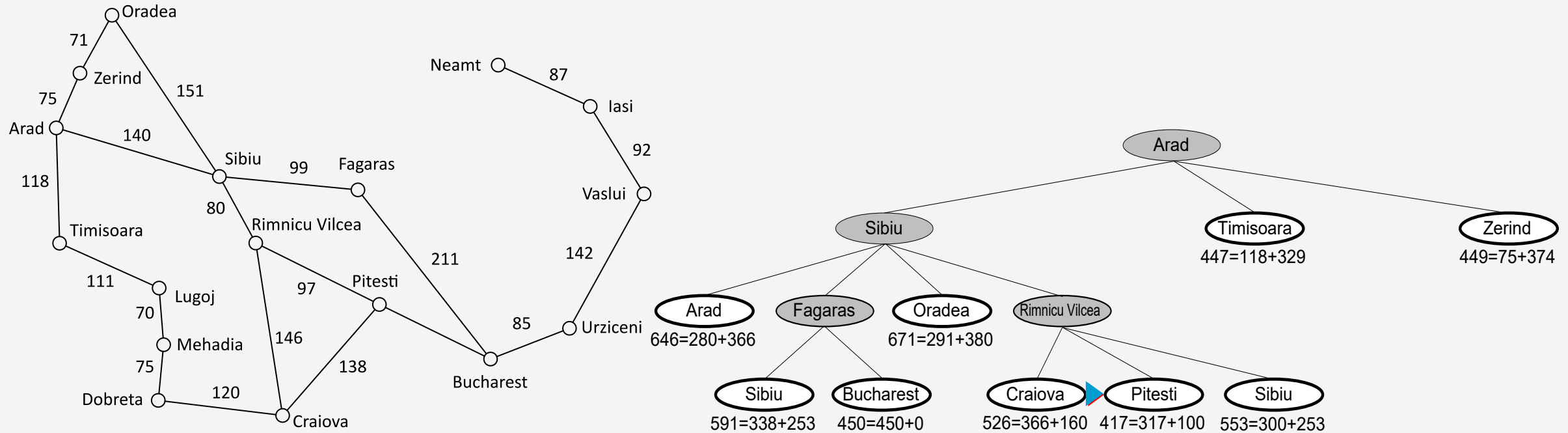

## Search-Tree Terminology

- **Node**: a pair  $v = (\pi, s), s = \gamma(s_0, \pi)$ 
  - In practice,  $v$  may contain other things: Pointer to parent,  $cost(\pi), \dots$
  - $\pi$  not always stored explicitly, can be computed from the parent pointers
- **Children** of  $v = \{(\pi.a, \gamma(s, a)) \mid a \text{ is applicable in } s\}$ 
  - $\pi.a$ : concatenation of  $\pi$  and  $a$
- **Successors** of  $v$ 
  - Children, children of children, etc.
- **Ancestors** of  $v$ 
  - Nodes that have  $v$  as a successor
- **Initial / starting** node:  $v_0 = (\langle \rangle, s_0)$ 
  - Root of the search tree

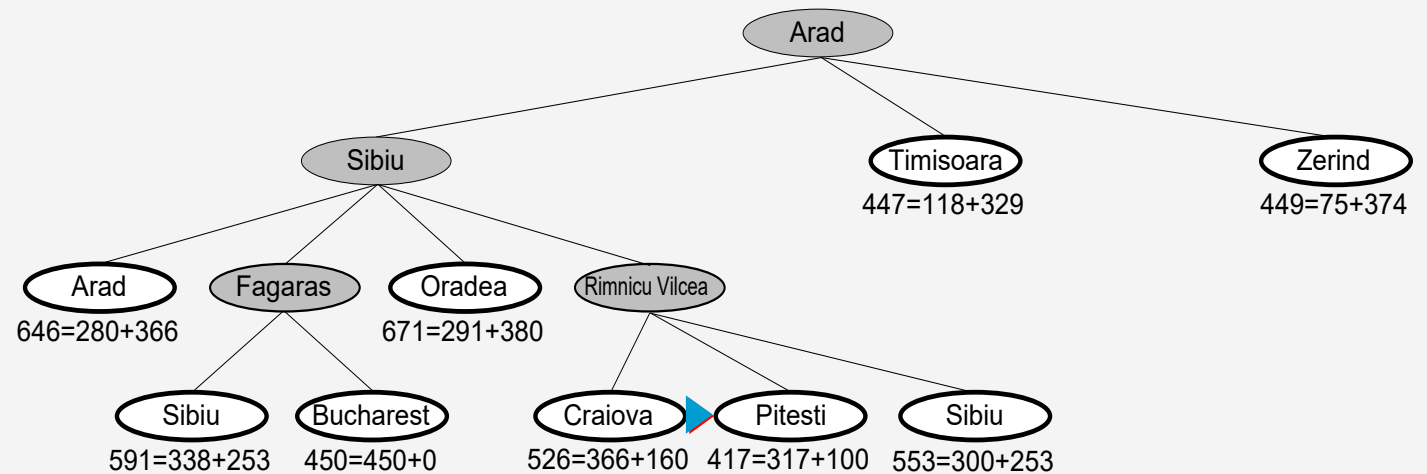

## Search-Tree Terminology

- **Expand**  $v$  = generate all children
- **Path** in the search space
  - Sequence  $\langle v_0, v_1, \dots, v_n \rangle$  s.t. each  $v_i$  is a child of  $v_{i-1}$
- **Height** of search space
  - Length of longest acyclic path from  $v_0$
- **Depth** of  $v$ 
  - Length of path from  $v_0$  to  $v$ ,  $\text{len}(\pi)$
- **Branching factor** of  $v$ 
  - Number of children
- **Branching factor** of search tree
  - Max branching factor of the nodes

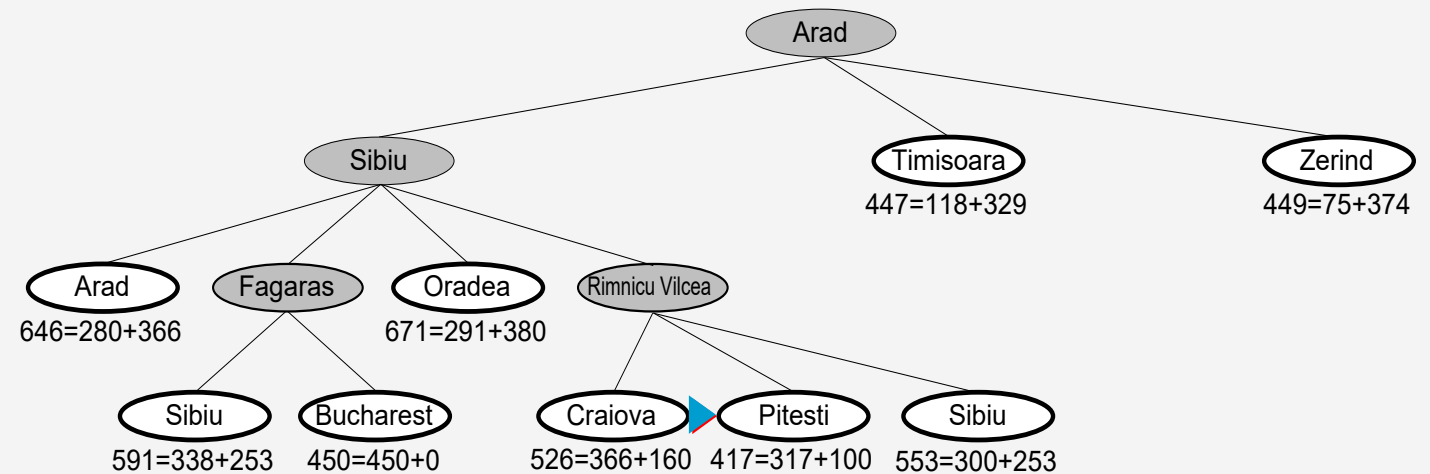

## Forward Search

- Nondeterministic algorithm
  - *Sound*: if an execution trace returns a plan  $\pi$ , it is a solution
  - *Complete*: if the planning problem is solvable, at least one of the possible execution traces will return a solution
- Represents a class of deterministic search algorithms
  - Depends on how you implement the nondeterministic choice
    - Which leaf node to expand next, which nodes to prune
  - Sound but not necessarily complete

```
Forward-search ( $\Sigma, s_0, g$ )
```

```
   $s \leftarrow s_0$ 
```

```
   $\pi \leftarrow \langle \rangle$ 
```

```
  loop
```

```
    if  $s$  satisfies  $g$  then
```

```
      return  $\pi$ 
```

```
     $A' \leftarrow \{a \in A \mid a \text{ is applicable in } s\}$ 
```

```
    if  $A' = \emptyset$  then
```

```
      return failure
```

```
    nondeterministically choose  $a \in A'$ 
```

```
     $s \leftarrow \gamma(s, a)$ 
```

```
     $\pi \leftarrow \pi.a$ 
```

Input: planning problem  $(\Sigma, s_0, g)$

- Same for deterministic versions next

## Deterministic Version

- Special cases
  - Depth-first, breadth-first, A\*
- Classify by
  - How they **select** nodes (step i)
  - How they **prune** nodes (step ii)
- Cycle checks during pruning:
  - Remove from children every node  $(\pi, s)$  that has an ancestor  $(\pi', s')$  such that  $s' = s$
  - In classical planning,  $S$  is finite
    - Cycle-checking will guarantee termination

### Deterministic-Search $(\Sigma, s_0, g)$

$Frontier \leftarrow \{(\langle \rangle, s_0)\}$

$Expanded \leftarrow \emptyset$

**while**  $Frontier \neq \emptyset$  **do**

    select a node  $v = (\pi, s) \in Frontier$  (i)

    remove  $v$  from  $Frontier$

    add  $v$  to  $Expanded$

**if**  $s$  satisfies  $g$  **then**

**return**  $\pi$

$Children \leftarrow \{(\pi.a, \gamma(s, a)) \mid s \text{ satisfies } pre(a)\}$

    prune 0 or more nodes from

$Children, Frontier, Expanded$  (ii)

$Frontier \leftarrow Frontier \cup Children$

**return** failure

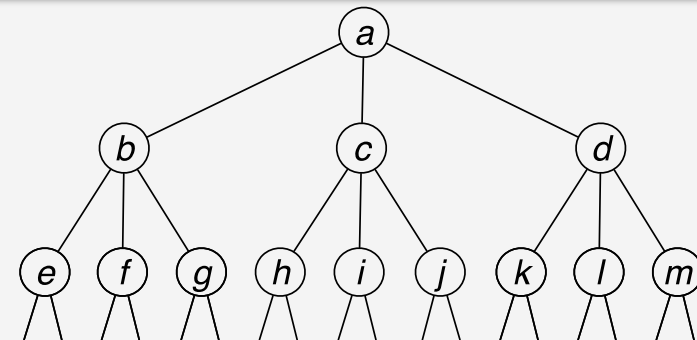

## Breadth-first search (BFS)

- (i) select  $(\pi, s) \in Frontier$  with smallest  $len(\pi)$ 
  - Tie-breaking rule: select oldest
- (ii) remove every  $(\pi, s) \in Children \cup Frontier$  such that  $s$  is in  $Expanded$ 
  - Thus expand states at most once

**Deterministic-Search**  $(\Sigma, s_0, g)$

$Frontier \leftarrow \{(\langle \rangle, s_0)\}$

$Expanded \leftarrow \emptyset$

**while**  $Frontier \neq \emptyset$  **do**

    select a node  $v = (\pi, s) \in Frontier$  (i)

    remove  $v$  from  $Frontier$

    add  $v$  to  $Expanded$

**if**  $s$  satisfies  $g$  **then**

**return**  $\pi$

$Children \leftarrow \{(\pi.a, \gamma(s, a)) \mid s \text{ satisfies } pre(a)\}$

    prune 0 or more nodes from

$Children, Frontier, Expanded$  (ii)

$Frontier \leftarrow Frontier \cup Children$

**return** failure

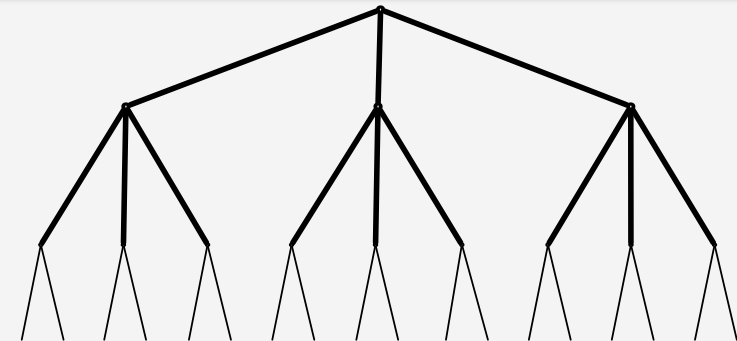

## Breadth-first search (BFS)

- Properties
  - Terminates
  - Returns solution if one exists
    - Shortest, but not least-cost (except if shortest = least-cost, e.g., default cost)
  - Worst-case complexity:
    - Memory  $O(|S|)$
    - Running time  $O(b|S|)$

where

- $b$  = max branching factor
- $|S|$  = number of states in  $S$

```
Deterministic-Search ( $\Sigma, s_0, g$ )
```

```
Frontier  $\leftarrow \{(\langle \rangle, s_0)\}$ 
```

```
Expanded  $\leftarrow \emptyset$ 
```

```
while Frontier  $\neq \emptyset$  do
```

```
    select a node  $v = (\pi, s) \in \textit{Frontier}$  (i)
```

```
    remove  $v$  from Frontier
```

```
    add  $v$  to Expanded
```

```
    if  $s$  satisfies  $g$  then
```

```
        return  $\pi$ 
```

```
    Children  $\leftarrow \{(\pi.a, \gamma(s,a)) \mid s \text{ satisfies } \textit{pre}(a)\}$ 
```

```
    prune 0 or more nodes from
```

```
        Children, Frontier, Expanded (ii)
```

```
    Frontier  $\leftarrow \textit{Frontier} \cup \textit{Children}$ 
```

```
return failure
```

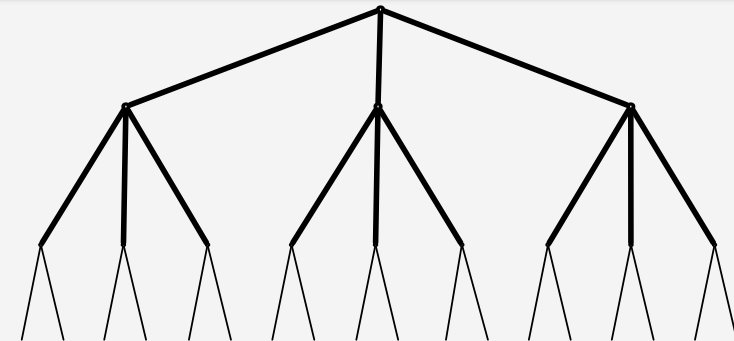

## Depth-First Search (DFS)

- (i) select  $(\pi, s) \in Children$  that has largest  $len(\pi)$ 
  - Possible tie-breaking rules:
    - left-to-right, smallest  $h(s)$  (some heuristic)
- (ii) first do cycle-checking, then prune all nodes by repeatedly removing from *Expanded* any node that has no children in  $Children \cup Frontier \cup Expanded$ 
  - What recursive DFS would discard

**Deterministic-Search** ( $\Sigma, s_0, g$ )

$Frontier \leftarrow \{(\langle \rangle, s_0)\}$

$Expanded \leftarrow \emptyset$

**while**  $Frontier \neq \emptyset$  **do**

    select a node  $v = (\pi, s) \in Frontier$  (i)

    remove  $v$  from  $Frontier$

    add  $v$  to  $Expanded$

**if**  $s$  satisfies  $g$  **then**

**return**  $\pi$

$Children \leftarrow \{(\pi.a, \gamma(s,a)) \mid s \text{ satisfies } pre(a)\}$

    prune 0 or more nodes from

$Children, Frontier, Expanded$  (ii)

$Frontier \leftarrow Frontier \cup Children$

**return** failure

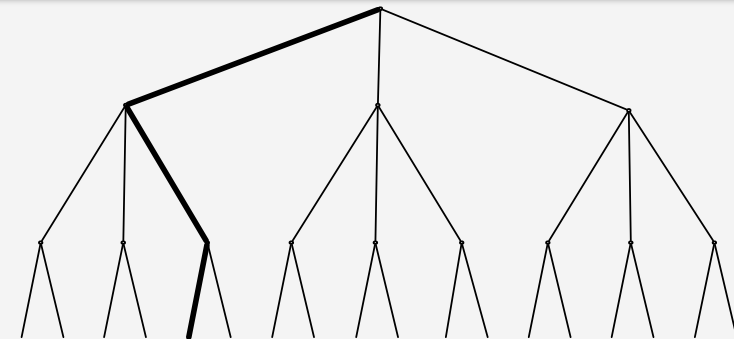

# Depth-First Search (DFS)

- Properties
    - Terminates
    - Returns solution if there is one
      - No guarantees on quality
    - Worst-case complexity
      - Running time  $O(b^l)$
      - Memory  $O(bl)$
- where
- $b$  = max branching factor
  - $l$  = max depth of any node

```
Deterministic-Search ( $\Sigma, s_0, g$ )  
   $Frontier \leftarrow \{(\langle \rangle, s_0)\}$   
   $Expanded \leftarrow \emptyset$   
  while  $Frontier \neq \emptyset$  do  
    select a node  $v = (\pi, s) \in Frontier$  (i)  
    remove  $v$  from  $Frontier$   
    add  $v$  to  $Expanded$   
    if  $s$  satisfies  $g$  then  
      return  $\pi$   
     $Children \leftarrow \{(\pi.a, \gamma(s,a)) \mid s \text{ satisfies } pre(a)\}$   
    prune 0 or more nodes from  
       $Children, Frontier, Expanded$  (ii)  
     $Frontier \leftarrow Frontier \cup Children$   
  return failure
```

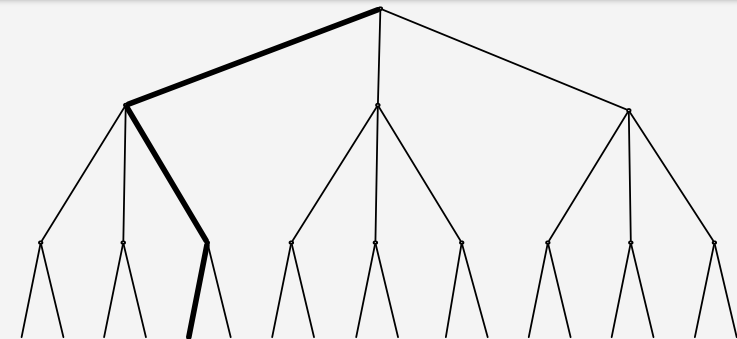

## Uniform-Cost Search

- (i) select  $(\pi, s) \in Children$  that has smallest  $cost(\pi)$
- (ii) prune every  $(\pi, s) \in Children \cup Frontier$  such that  $Expanded$  already contains a node  $(\pi', s)$ 
  - $cost(\pi') \leq cost(\pi)$ , so we only keep the least-cost path to  $s$

**Deterministic-Search**  $(\Sigma, s_0, g)$

$Frontier \leftarrow \{(\langle \rangle, s_0)\}$

$Expanded \leftarrow \emptyset$

**while**  $Frontier \neq \emptyset$  **do**

    select a node  $v = (\pi, s) \in Frontier$  (i)

    remove  $v$  from  $Frontier$

    add  $v$  to  $Expanded$

**if**  $s$  satisfies  $g$  **then**

**return**  $\pi$

$Children \leftarrow \{(\pi.a, \gamma(s, a)) \mid s \text{ satisfies } pre(a)\}$

    prune 0 or more nodes from

$Children, Frontier, Expanded$  (ii)

$Frontier \leftarrow Frontier \cup Children$

**return** failure

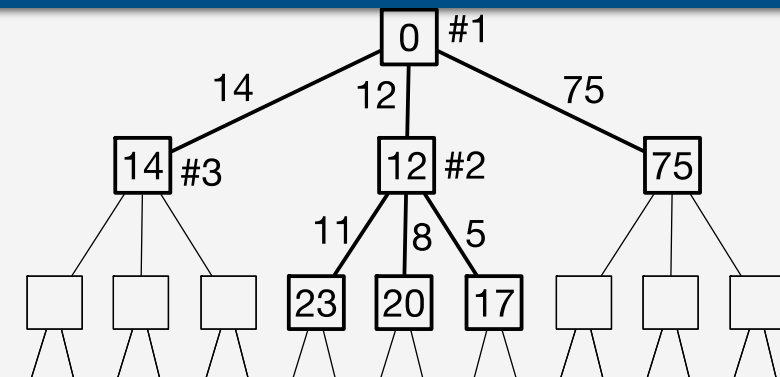

# Uniform-Cost Search

- Properties
  - Terminates
  - Finds optimal solution if one exists
  - Worst-case complexity
    - Memory  $O(|S|)$
    - Time  $O(b|S|)$
- where
  - $b$  = max branching factor
  - $|S|$  = number of states in  $S$

**Deterministic-Search** ( $\Sigma, s_0, g$ )

$Frontier \leftarrow \{(\langle \rangle, s_0)\}$

$Expanded \leftarrow \emptyset$

**while**  $Frontier \neq \emptyset$  **do**

  select a node  $v = (\pi, s) \in Frontier$  (i)

  remove  $v$  from  $Frontier$

  add  $v$  to  $Expanded$

**if**  $s$  satisfies  $g$  **then**

**return**  $\pi$

$Children \leftarrow \{(\pi.a, \gamma(s,a)) \mid s \text{ satisfies } pre(a)\}$

  prune 0 or more nodes from

$Children, Frontier, Expanded$  (ii)

$Frontier \leftarrow Frontier \cup Children$

**return** failure

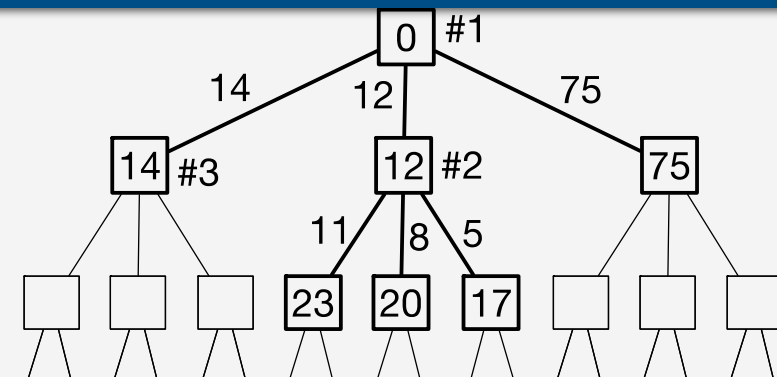

## Heuristic Function

- Motivation: get to a solution quickly by selecting nodes close to the goal (see  $A^*$ )
- Let  $h^*(s) = \min\{cost(\pi) \mid \gamma(s, \pi) \text{ satisfies } g\}$ 
  - Note that  $h^*(s) \geq 0$  for all  $s$
- **Heuristic function**  $h(s)$ :
  - Returns an estimate of  $h^*(s)$ 
    - Assume  $h(s) \geq 0$  for all  $s$
  - Properties
    - $h$  is **admissible** if for every  $s$ ,  $h(s) \leq h^*(s)$
    - $h$  is  **$\epsilon$ -admissible** if for every  $s$ ,  $h(s) \leq h^*(s) + \epsilon$
- Let  $v = (\pi, s)$  be a node
  - $f^*(v) = cost(\pi) + h^*(s)$ 
    - Min cost of all paths to goal that start with  $\pi$
  - $f(v) = cost(\pi) + h(s)$ 
    - Estimate of  $f^*(v)$

## Example

- State  $s$  = what city you are in, goal  $g \triangleq (s = \text{Bucharest})$
- Action: follow road from  $s$  to a neighboring city
- $h^*(s)$  = length of shortest sequence of roads from  $s$  to Bucharest
- $h(s)$  = straight-line distance from  $s$  to Bucharest
  - *Domain-specific; later we discuss domain-independent heuristics*
- $f^*((\pi, s))$  = length of  $\pi$  + shortest sequence of roads from  $s$  to Bucharest

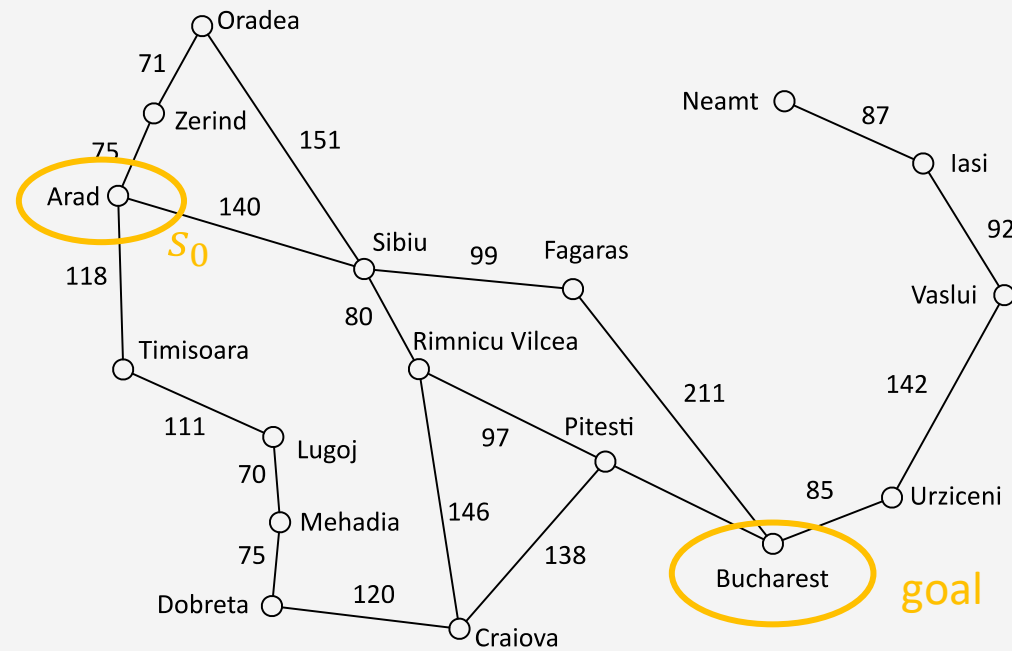

straight-line dist.  
from  $s$  to Bucharest

Arad	366
Bucharest	0
Craiova	160
Dobreta	242
Fagaras	176
Iasi	226
Lugoj	244
Mehadia	241
Neamt	234
Oradea	380
Pitesti	100
Rimnicu Vilcea	193
Sibiu	253
Timisoara	329
Urziceni	80
Vaslui	199
Zerind	374

## A\*

- (i) Select a node  $v = (\pi, s)$  in *Frontier* that has smallest value of
$$f(v) = cost(\pi) + h(s)$$
  - Tie-breaking rule: choose oldest
- (ii) for every node  $v = (\pi, s)$  in *Children*
  - if  $Children \cup Frontier \cup Expanded$  contains more than one node for  $s$  (different  $\pi$ )
    - Then it has multiple paths to  $s$
    - Keep only the one with the lowest  $f$ -value
  - Tie-breaking rule: keep oldest

### Deterministic-Search ( $\Sigma, s_0, g$ )

```
Frontier  $\leftarrow$  {( $\langle \rangle$ ,  $s_0$ )}
```

```
Expanded  $\leftarrow$   $\emptyset$ 
```

```
while Frontier  $\neq$   $\emptyset$  do
```

```
    select a node  $v = (\pi, s) \in$  Frontier (i)
```

```
    remove  $v$  from Frontier
```

```
    add  $v$  to Expanded
```

```
    if  $s$  satisfies  $g$  then
```

```
        return  $\pi$ 
```

```
    Children  $\leftarrow$  {( $\pi.a$ ,  $\gamma(s, a)$ ) |  $s$  satisfies  $pre(a)$ }
```

```
    prune 0 or more nodes from
```

```
        Children, Frontier, Expanded (ii)
```

```
    Frontier  $\leftarrow$  Frontier  $\cup$  Children
```

```
return failure
```



straight-line dist.  
from  $s$  to Bucharest

Arad	366
Bucharest	0
Craiova	160
Dobreta	242
Fagaras	176
Iasi	226
Lugoj	244
Mehadia	241
Neamt	234
Oradea	380
Pitesti	100
Rimnicu Vilcea	193
Sibiu	253
Timisoara	329
Urziceni	80
Vaslui	199
Zerind	374

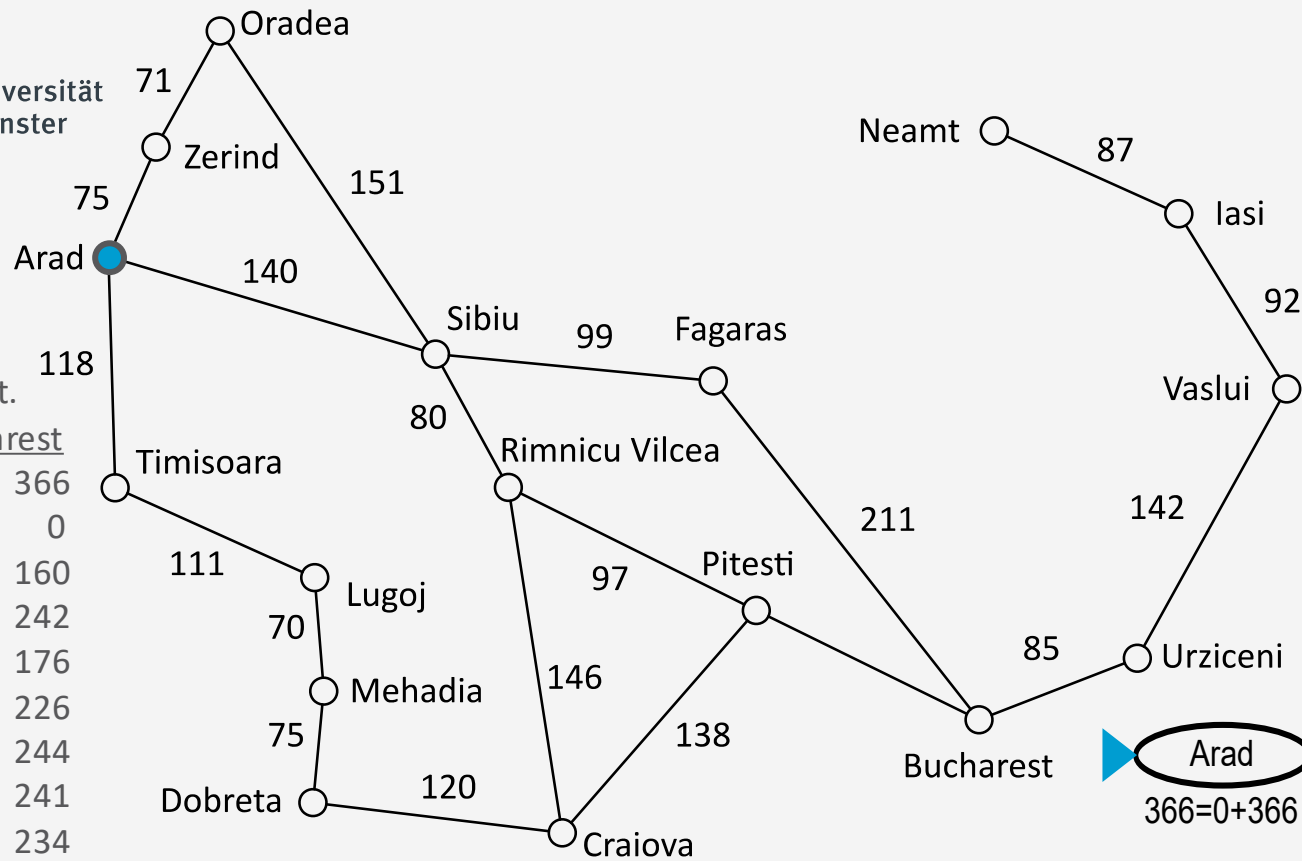

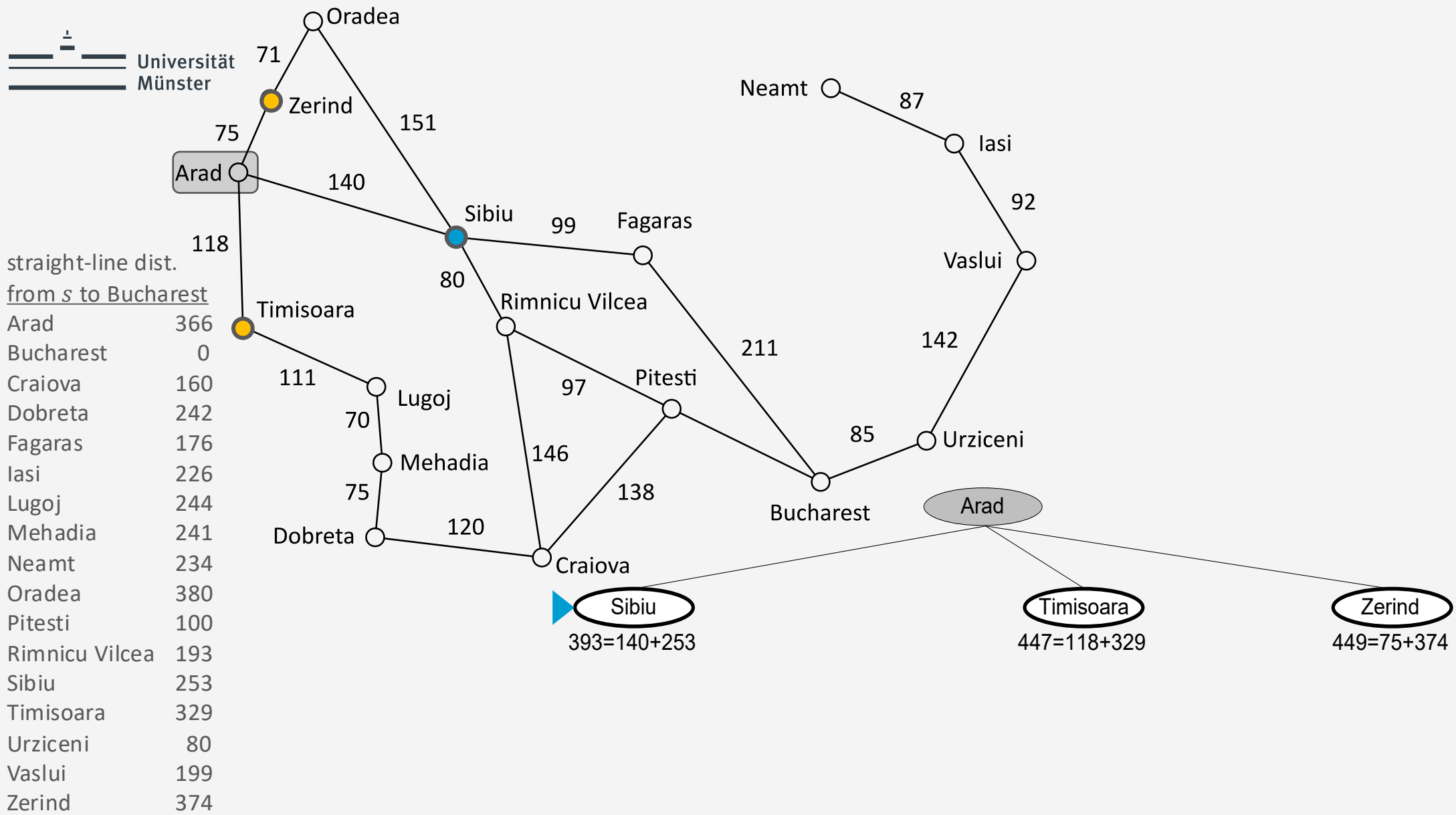

straight-line dist.  
from *s* to Bucharest

Arad	366
Bucharest	0
Craiova	160
Dobreta	242
Fagaras	176
Iasi	226
Lugoj	244
Mehadia	241
Neamt	234
Oradea	380
Pitesti	100
Rimnicu Vilcea	193
Sibiu	253
Timisoara	329
Urziceni	80
Vaslui	199
Zerind	374

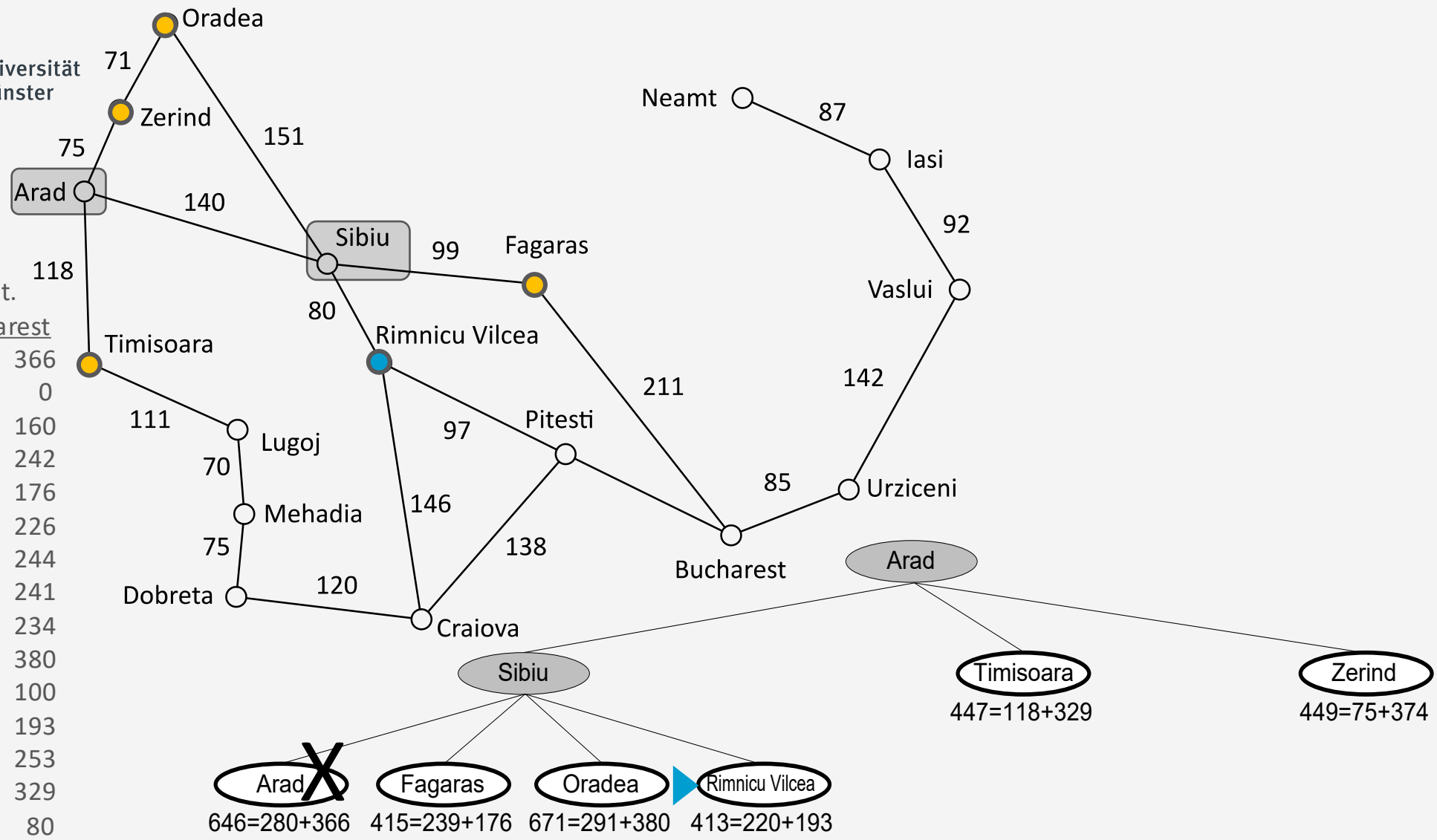



straight-line dist.  
from *s* to Bucharest

Arad	366
Bucharest	0
Craiova	160
Dobreta	242
Fagaras	176
Iasi	226
Lugoj	244
Mehadia	241
Neamt	234
Oradea	380
Pitesti	100
Rimnicu Vilcea	193
Sibiu	253
Timisoara	329
Urziceni	80
Vaslui	199
Zerind	374

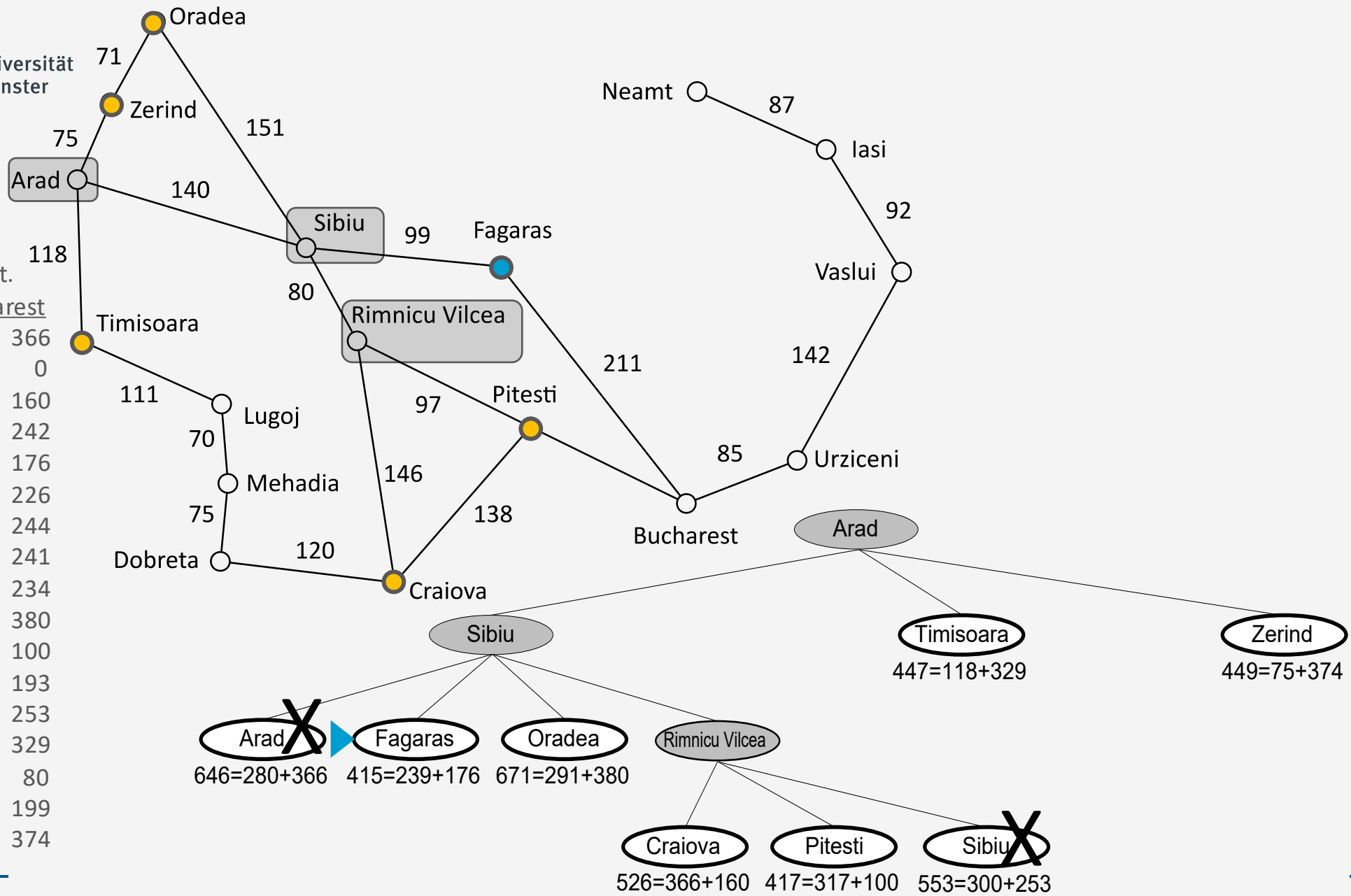

straight-line dist.  
from *s* to Bucharest

Arad	366
Bucharest	0
Craiova	160
Dobreta	242
Fagaras	176
Iasi	226
Lugoj	244
Mehadia	241
Neamt	234
Oradea	380
Pitesti	100
Rimnicu Vilcea	193
Sibiu	253
Timisoara	329
Urziceni	80
Vaslui	199
Zerind	374

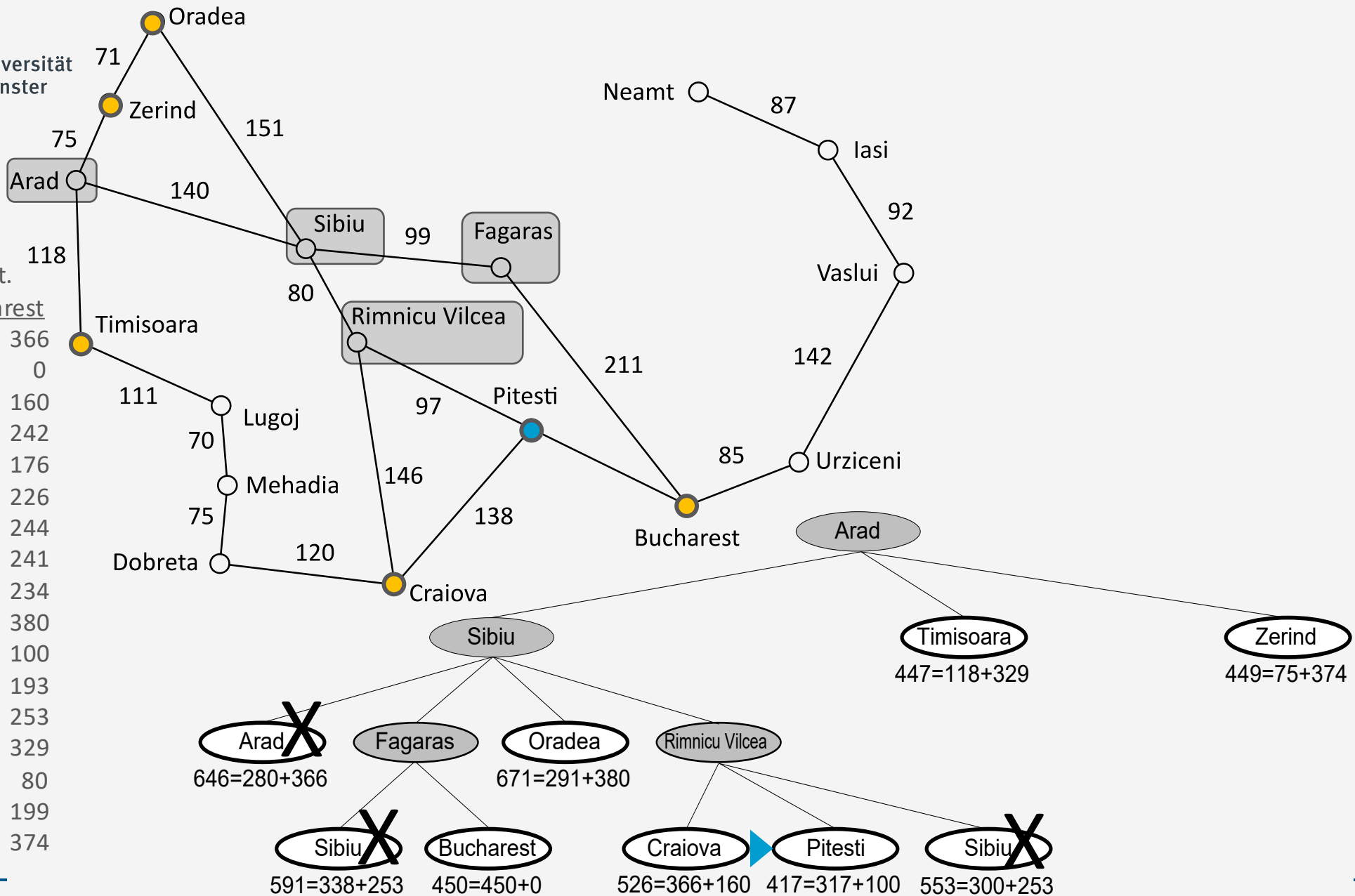

straight-line dist.  
from *s* to Bucharest

Arad	366
Bucharest	0
Craiova	160
Dobreta	242
Fagaras	176
Iasi	226
Lugoj	244
Mehadia	241
Neamt	234
Oradea	380
Pitesti	100
Rimnicu Vilcea	193
Sibiu	253
Timisoara	329
Urziceni	80
Vaslui	199
Zerind	374

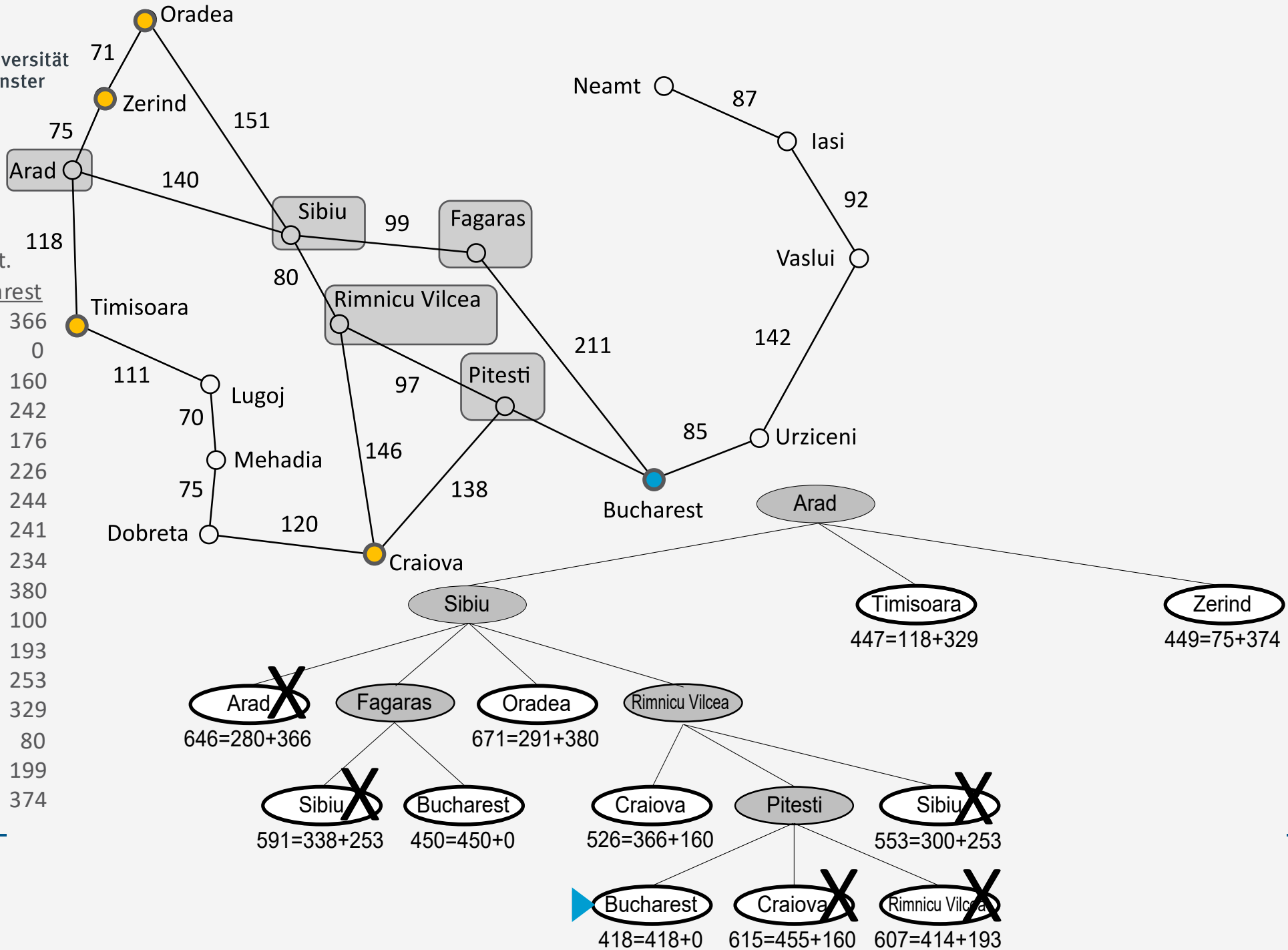

## Properties of A\*

- In classical planning problems, A\* will always terminate
- *Completeness*: if the problem is solvable, A\* will return a solution
  - If  $h$  is admissible, then the solution will be optimal (least cost)
  - If  $h$  is  $\varepsilon$ -admissible, then the solution will be  $\varepsilon$ -optimal
- If  $h$  is monotone, then
  - $f(v) \leq f(v')$  for every child  $v'$  of a node  $v$
  - A\* will expand nodes in non-decreasing order of  $f$  values
  - A\* will never prune any nodes from *Expanded*
  - A\* will expand no state more than once

## Properties of A\*

- Definition:  $h$  dominates  $h'$  if  $h'(s) \leq h(s) \leq h^*(s)$  for every  $s$ 
  - If  $h$  dominates  $h'$ , then (assuming ties are always resolved in favour of the same node)
    - A\* will never expand more nodes with  $h$  than with  $h'$
    - In most cases A\* will expand fewer nodes with  $h$  than with  $h'$
- A\* needs to store every node it visits
  - Running time  $O(b|S|)$  and memory  $O(|S|)$  in worst case
  - With good heuristic function, usually much smaller

## Greedy Best-First Search (GBFS)

- Find a solution as quickly as possible, even if it is not optimal
  - Select nodes that are likely to be on the least-cost path from where you are now
  - (i) select a node  $(\pi, s) \in Frontier$  that has smallest  $h(s)$
  - (ii) same as in A\*: for every node  $v = (\pi, s)$  in *Children*
    - If  $Children \cup Frontier \cup Expanded$  contains more than one node for  $s$ 
      - Then it has multiple paths to  $s$
      - Keep only the one with the lowest f-value
    - Tie-breaking rule: keep oldest

```
Deterministic-Search ( $\Sigma, s_0, g$ )
```

```
Frontier  $\leftarrow \{(\langle \rangle, s_0)\}$ 
```

```
Expanded  $\leftarrow \emptyset$ 
```

```
while Frontier  $\neq \emptyset$  do
```

```
    select a node  $v = (\pi, s) \in Frontier$  (i)
```

```
    remove  $v$  from Frontier
```

```
    add  $v$  to Expanded
```

```
    if  $s$  satisfies  $g$  then
```

```
        return  $\pi$ 
```

```
    Children  $\leftarrow \{(\pi.a, \gamma(s, a)) \mid s \text{ satisfies } pre(a)\}$ 
```

```
    prune 0 or more nodes from
```

```
        Children, Frontier, Expanded (ii)
```

```
    Frontier  $\leftarrow Frontier \cup Children$ 
```

```
return failure
```

## Greedy Best-First Search (GBFS)

- Properties
  - Terminates
  - Returns a solution if one exists
    - Often near-optimal
    - Will usually find it quickly

```
Deterministic-Search ( $\Sigma, s_0, g$ )
```

```
Frontier  $\leftarrow \{(\langle \rangle, s_0)\}$ 
```

```
Expanded  $\leftarrow \emptyset$ 
```

```
while Frontier  $\neq \emptyset$  do
```

```
    select a node  $v = (\pi, s) \in \textit{Frontier}$  (i)
```

```
    remove  $v$  from Frontier
```

```
    add  $v$  to Expanded
```

```
    if  $s$  satisfies  $g$  then
```

```
        return  $\pi$ 
```

```
    Children  $\leftarrow \{(\pi.a, \gamma(s,a)) \mid s \text{ satisfies } \textit{pre}(a)\}$ 
```

```
    prune 0 or more nodes from
```

```
        Children, Frontier, Expanded (ii)
```

```
    Frontier  $\leftarrow \textit{Frontier} \cup \textit{Children}$ 
```

```
return failure
```

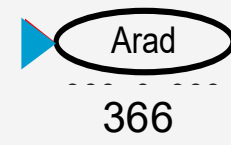
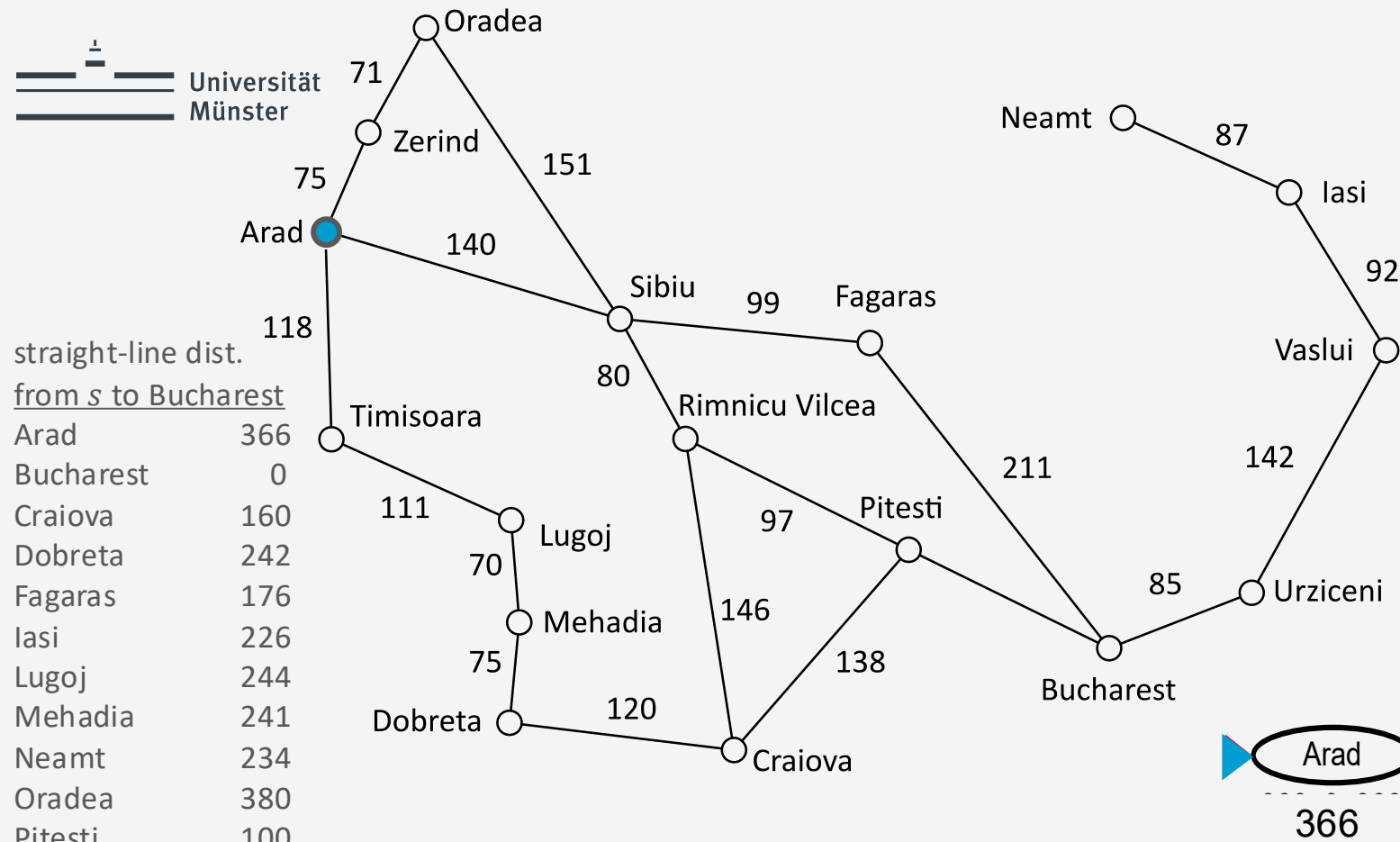

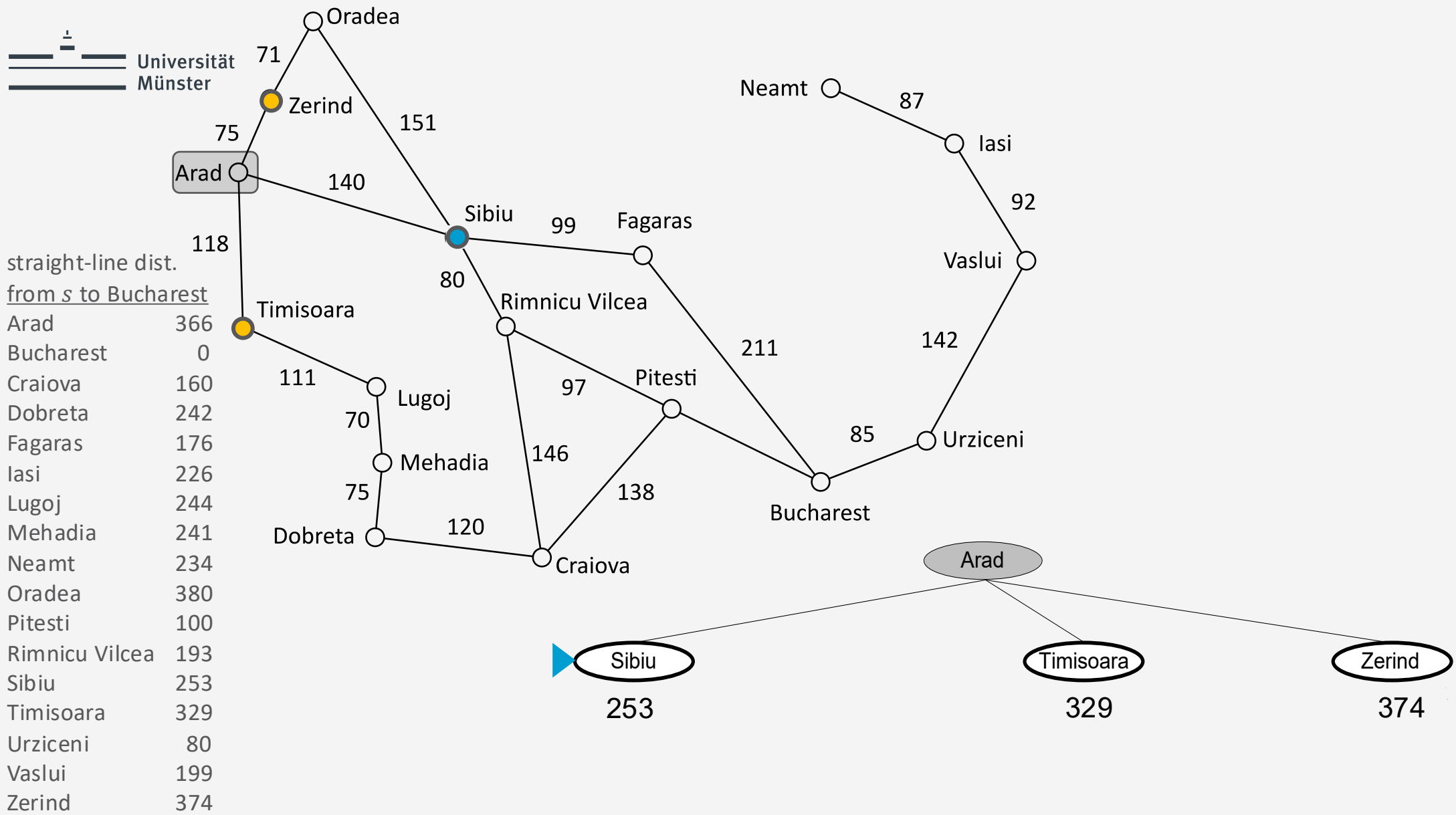

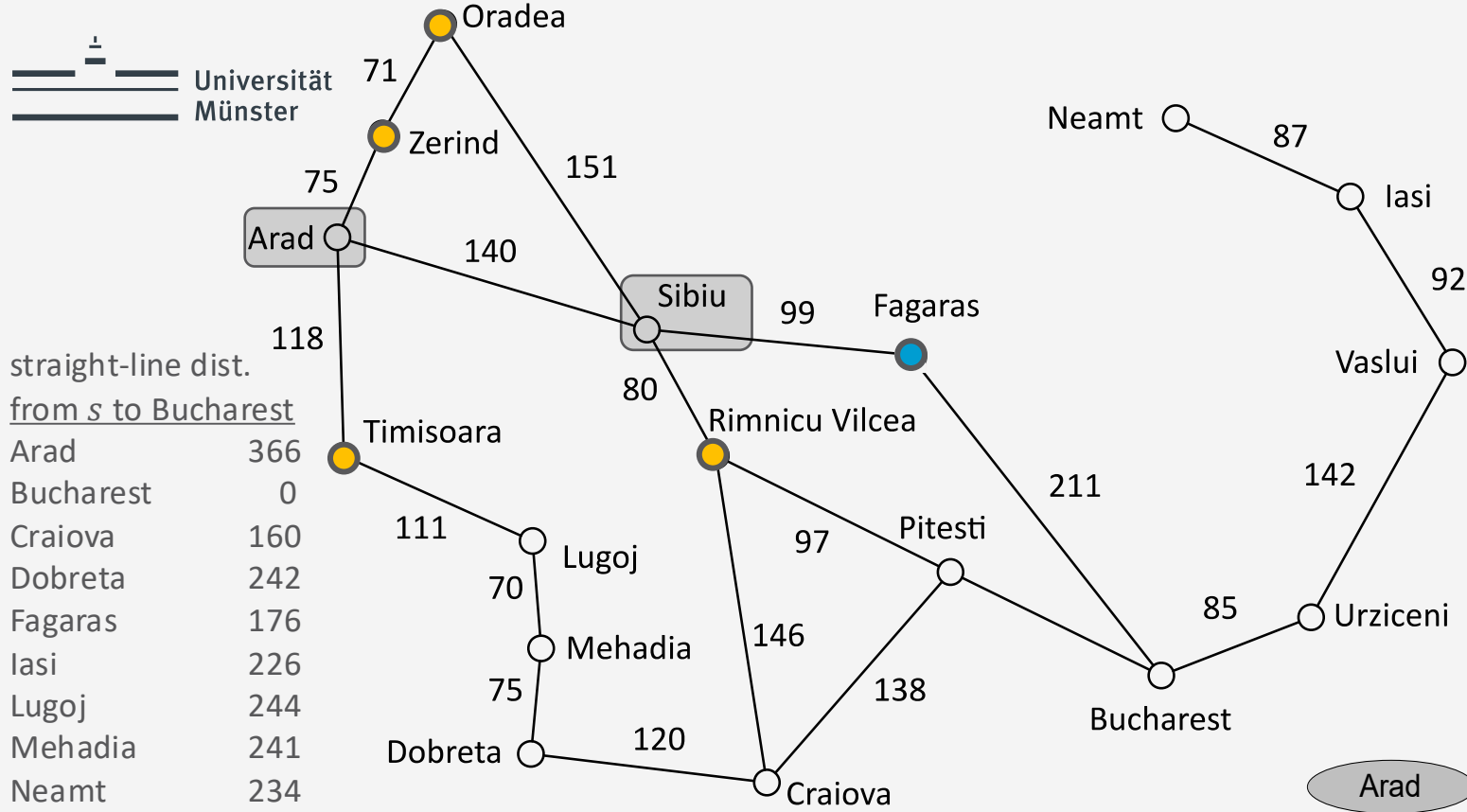

straight-line dist.  
from *s* to Bucharest

Arad	366
Bucharest	0
Craiova	160
Dobreta	242
Fagaras	176
Iasi	226
Lugoj	244
Mehadia	241
Neamt	234
Oradea	380
Pitesti	100
Rimnicu Vilcea	193
Sibiu	253
Timisoara	329
Urziceni	80
Vaslui	199
Zerind	374

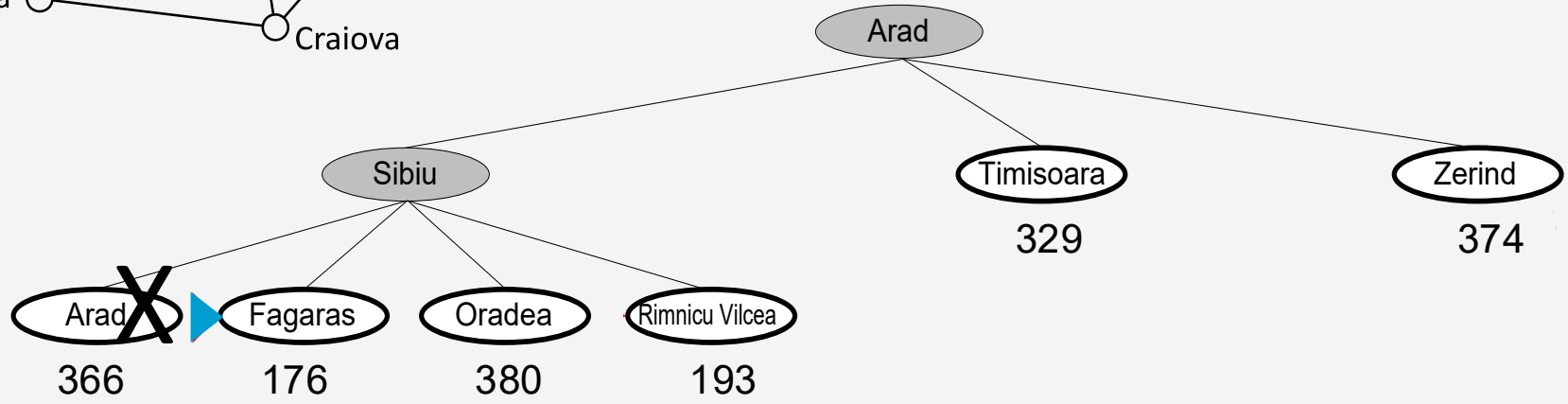

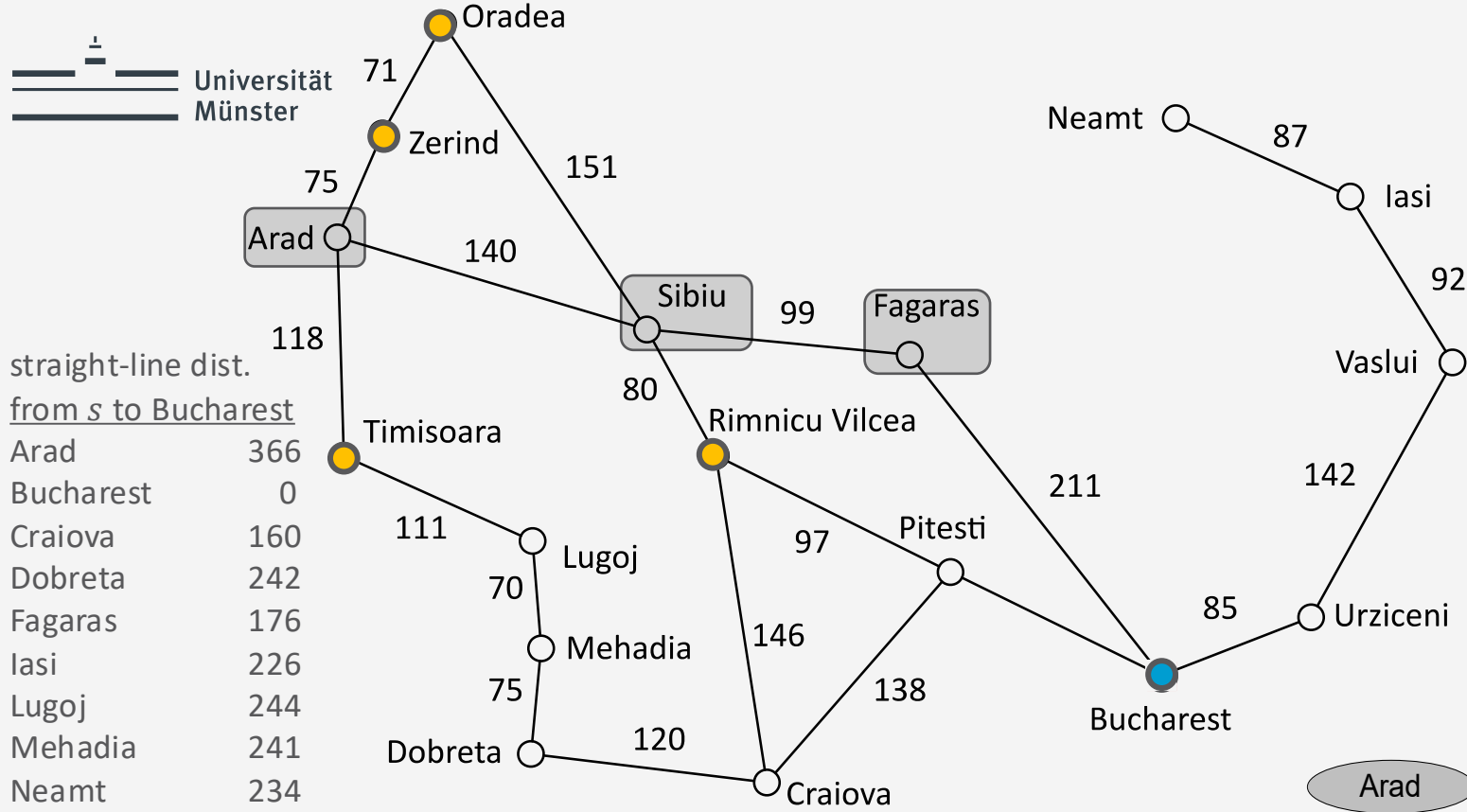

straight-line dist.  
from *s* to Bucharest

Arad	366
Bucharest	0
Craiova	160
Dobreta	242
Fagaras	176
Iasi	226
Lugoj	244
Mehadia	241
Neamt	234
Oradea	380
Pitesti	100
Rimnicu Vilcea	193
Sibiu	253
Timisoara	329
Urziceni	80
Vaslui	199
Zerind	374

- Expanded 4 nodes
- Instead of 6
- Solution cost 450
- Instead of 418

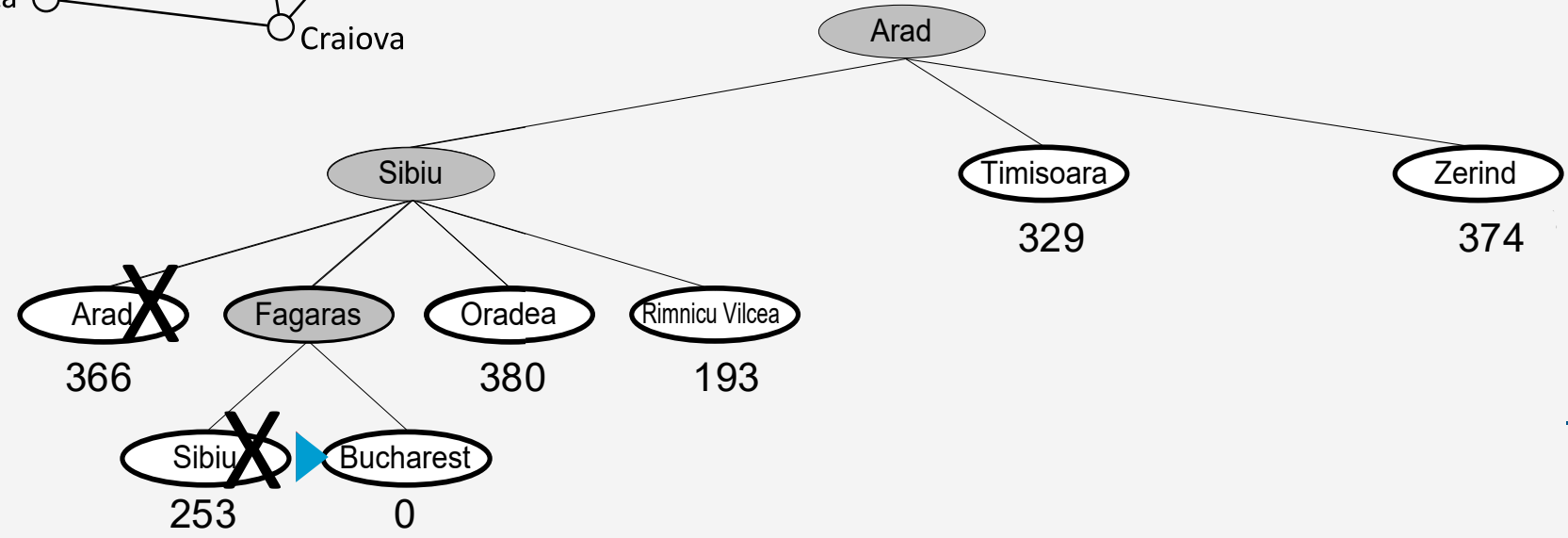

## Depth-First Branch and Bound (DFBB)

- (i) same as DFS
  - Select  $v = (\pi, s) \in Children$  that has largest  $len(\pi)$
  - Tie-breaking: smallest  $f(s)$
- (ii) prune
  - Like DFS
    - Do cycle-checking and prune what recursive DFS would discard
  - Additional pruning during node expansion:
    - If  $f(v) \geq c^*$ , then discard  $v$

**Deterministic-Search** ( $\Sigma, s_0, g$ )

$Frontier \leftarrow \{(\langle \rangle, s_0)\}$

$Expanded \leftarrow \emptyset$

$c^* \leftarrow \infty$

$\pi^* \leftarrow failure$

**while**  $Frontier \neq \emptyset$  **do**

  select a node  $v = (\pi, s) \in Frontier$  (i)

  remove  $v$  from  $Frontier$

  add  $v$  to  $Expanded$

~~**if**  $s$  satisfies  $g$  **then**~~

~~**return**  $\pi$~~

**if**  $s$  satisfies  $g$  and  $cost(\pi) < c^*$  **then**

$c^* \leftarrow cost(\pi)$ ;  $\pi^* \leftarrow \pi$

**else if**  $f(v) < c^*$  **then**

$Children \leftarrow \{(\pi.a, \gamma(s, a)) \mid$

$s$  satisfies  $pre(a)\}$

    prune 0 or more nodes from

$Children, Frontier, Expanded$  (ii)

$Frontier \leftarrow Frontier \cup Children$

**return** failure  $\pi^*$

## Depth-First Branch and Bound (DFBB)

- Properties
  - Termination, completeness, optimality same as A\*
  - Usually less memory than A\*, but more time
  - Worst-case like DFS:
    - $O(bl)$  memory
    - $O(b^l)$  running time

```
Deterministic-Search( $\Sigma, s_0, g$ )
```

```
Frontier  $\leftarrow$  {( $\langle \rangle, s_0$ )}
```

```
Expanded  $\leftarrow$   $\emptyset$ 
```

```
 $c^* \leftarrow \infty$ 
```

```
 $\pi^* \leftarrow$  failure
```

```
while Frontier  $\neq$   $\emptyset$  do
```

```
  select a node  $v = (\pi, s) \in$  Frontier (i)
```

```
  remove  $v$  from Frontier
```

```
  add  $v$  to Expanded
```

```
  if  $s$  satisfies  $g$  then
```

```
    return  $\pi$ 
```

```
  if  $s$  satisfies  $g$  and  $\text{cost}(\pi) < c^*$  then
```

```
     $c^* \leftarrow \text{cost}(\pi)$ ;  $\pi^* \leftarrow \pi$ 
```

```
  else if  $f(v) < c^*$  then
```

```
    Children  $\leftarrow$  {( $\pi.a, \gamma(s, a)$ ) |
```

```
       $s$  satisfies  $\text{pre}(a)$ }
```

```
    prune 0 or more nodes from
```

```
      Children, Frontier, Expanded (ii)
```

```
    Frontier  $\leftarrow$  Frontier  $\cup$  Children
```

```
return failure  $\pi^*$ 
```



straight-line dist.  
from  $s$  to Bucharest

Arad	366
Bucharest	0
Craiova	160
Dobreta	242
Fagaras	176
Iasi	226
Lugoj	244
Mehadia	241
Neamt	234
Oradea	380
Pitesti	100
Rimnicu Vilcea	193
Sibiu	253
Timisoara	329
Urziceni	80
Vaslui	199
Zerind	374

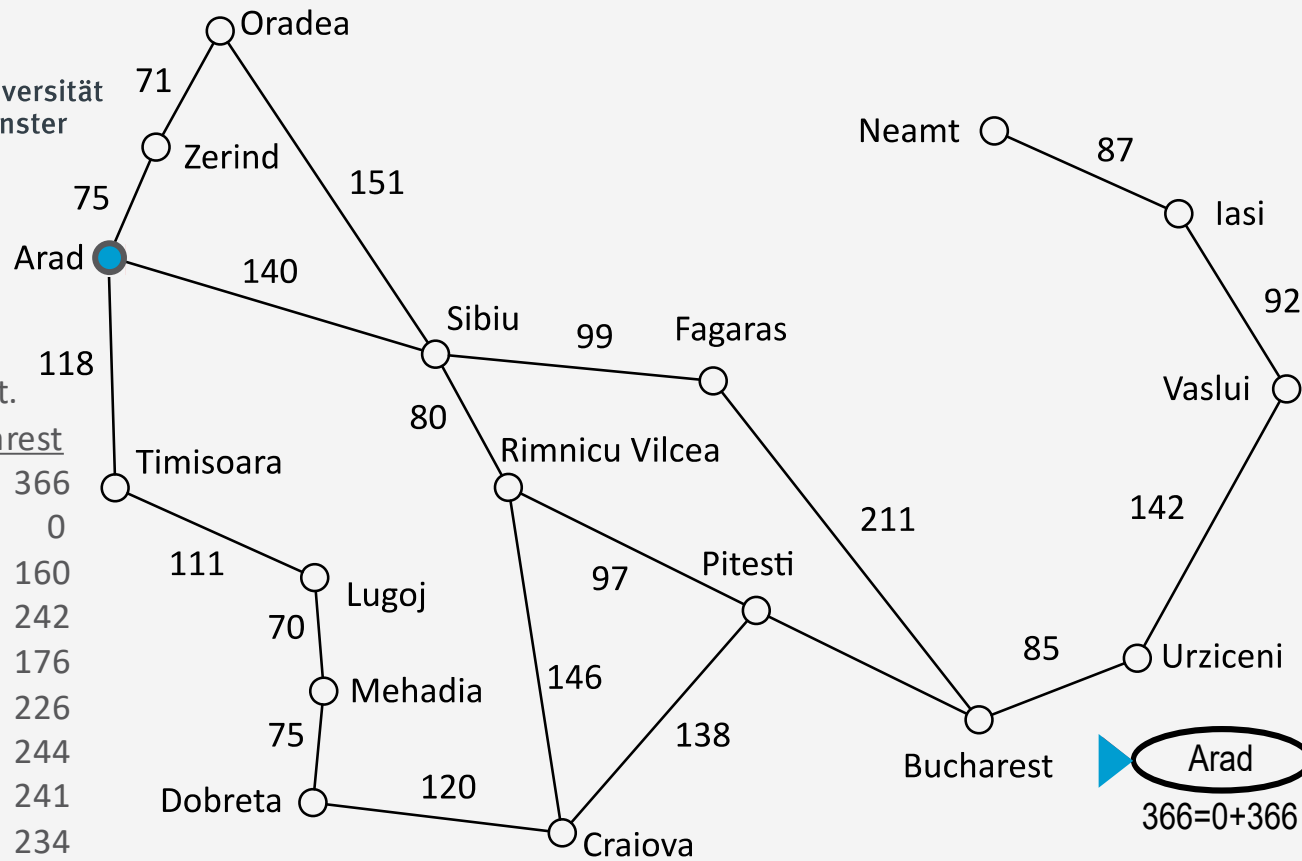

Arad  
 $366=0+366$

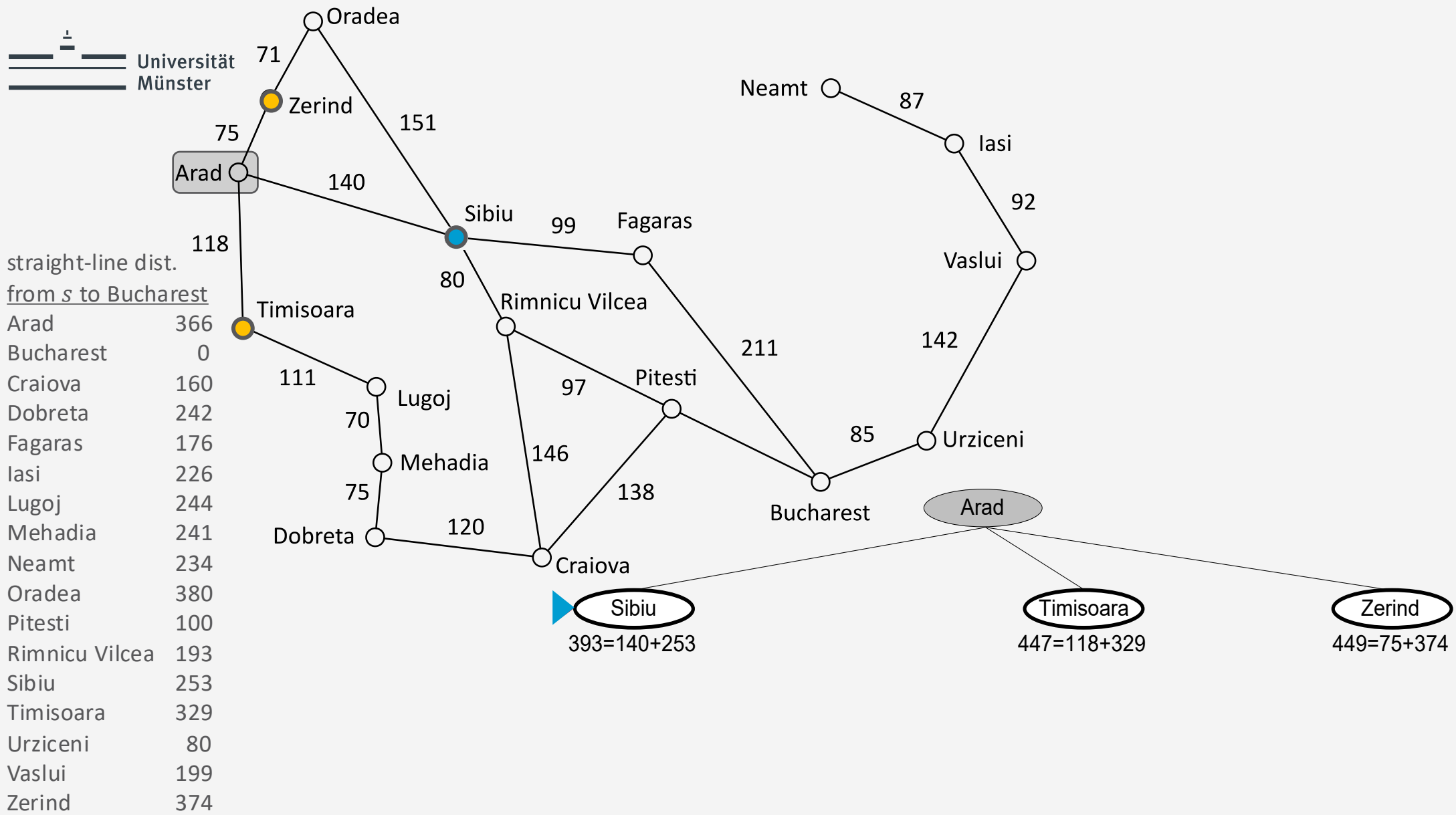

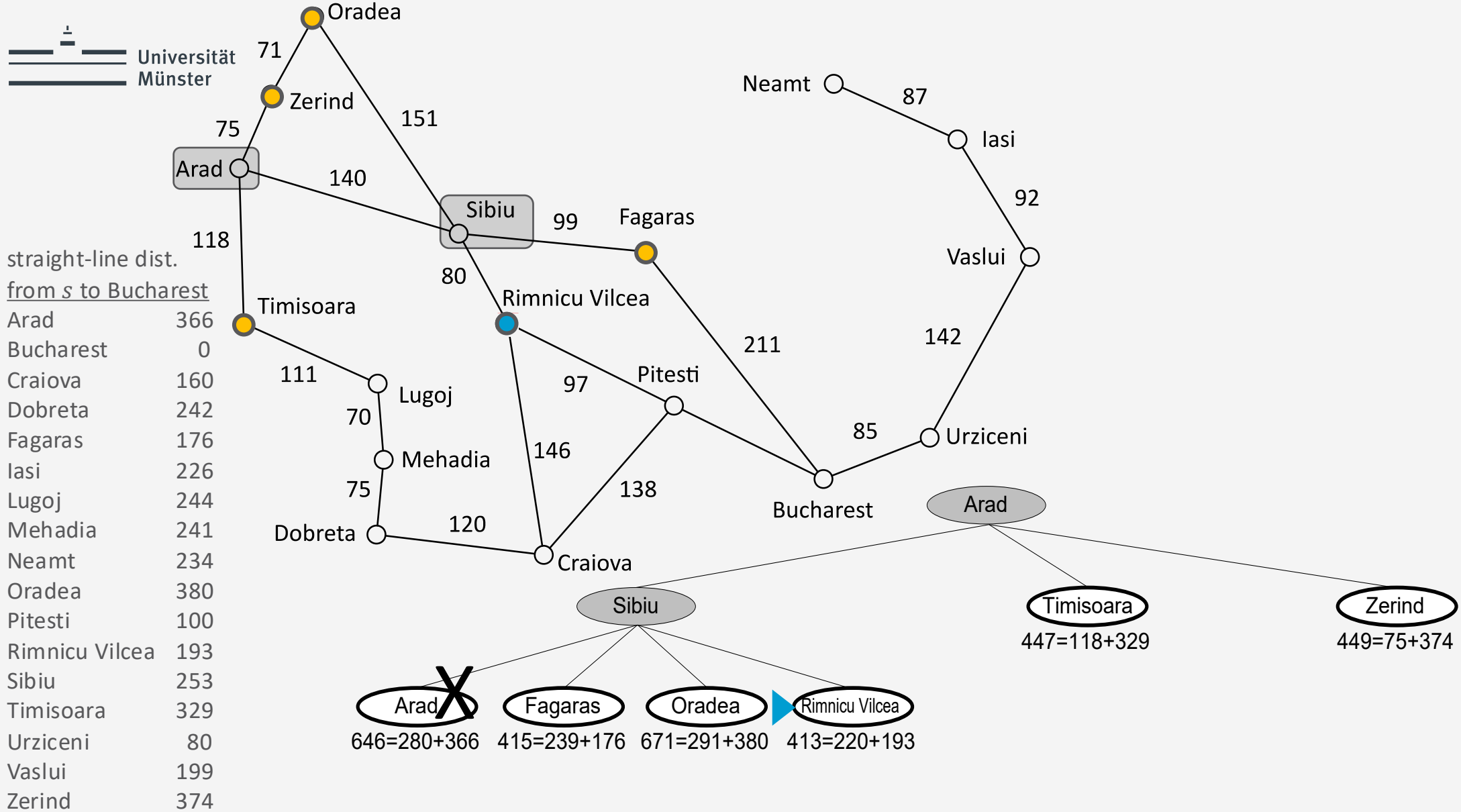

straight-line dist.  
from  $s$  to Bucharest

Arad	366
Bucharest	0
Craiova	160
Dobreta	242
Fagaras	176
Iasi	226
Lugoj	244
Mehadia	241
Neamt	234
Oradea	380
Pitesti	100
Rimnicu Vilcea	193
Sibiu	253
Timisoara	329
Urziceni	80
Vaslui	199
Zerind	374

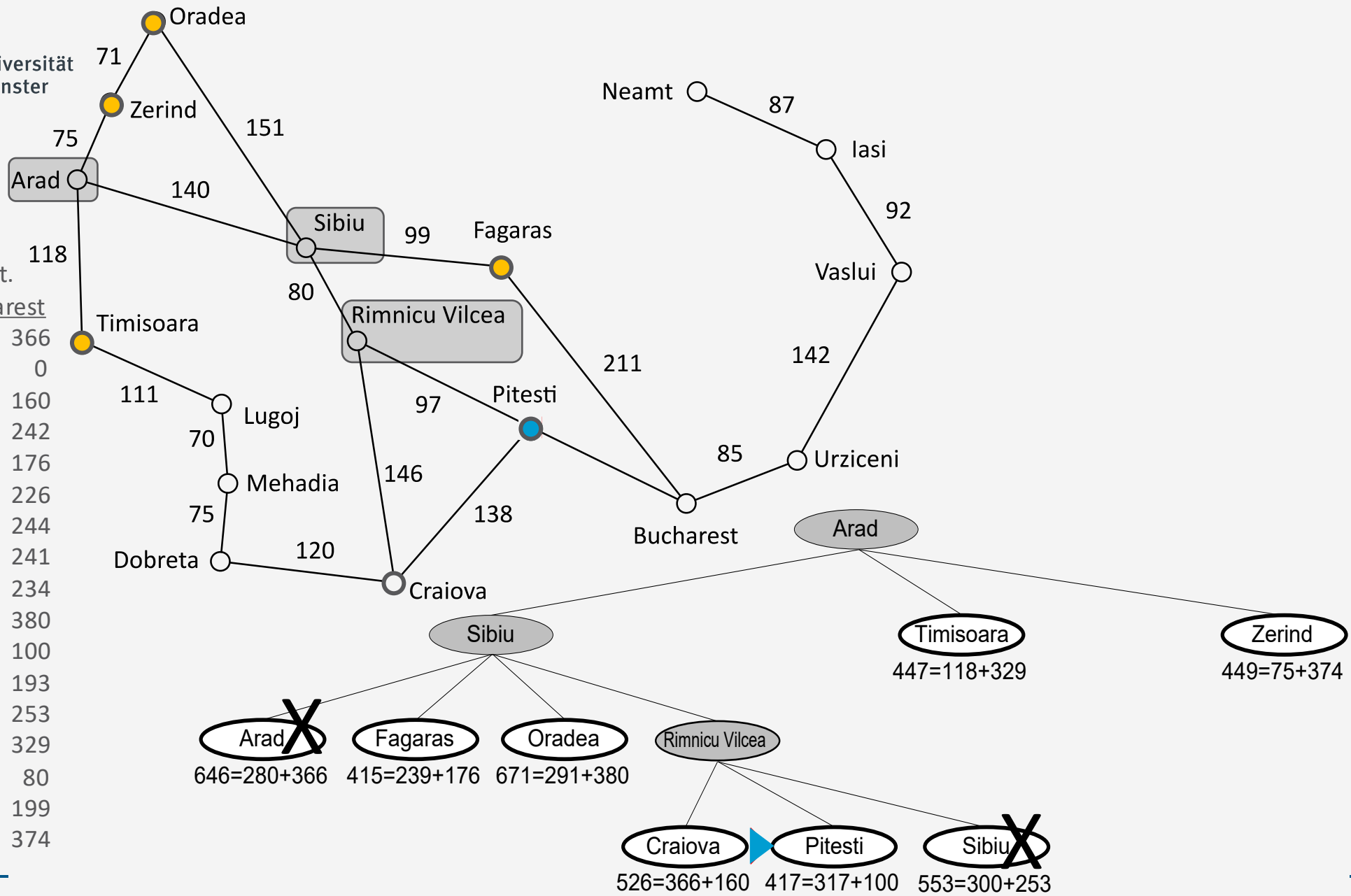



straight-line dist.  
from *s* to Bucharest

Arad	366
Bucharest	0
Craiova	160
Dobreta	242
Fagaras	176
Iasi	226
Lugoj	244
Mehadia	241
Neamt	234
Oradea	380
Pitesti	100
Rimnicu Vilcea	193
Sibiu	253
Timisoara	329
Urziceni	80
Vaslui	199
Zerind	374

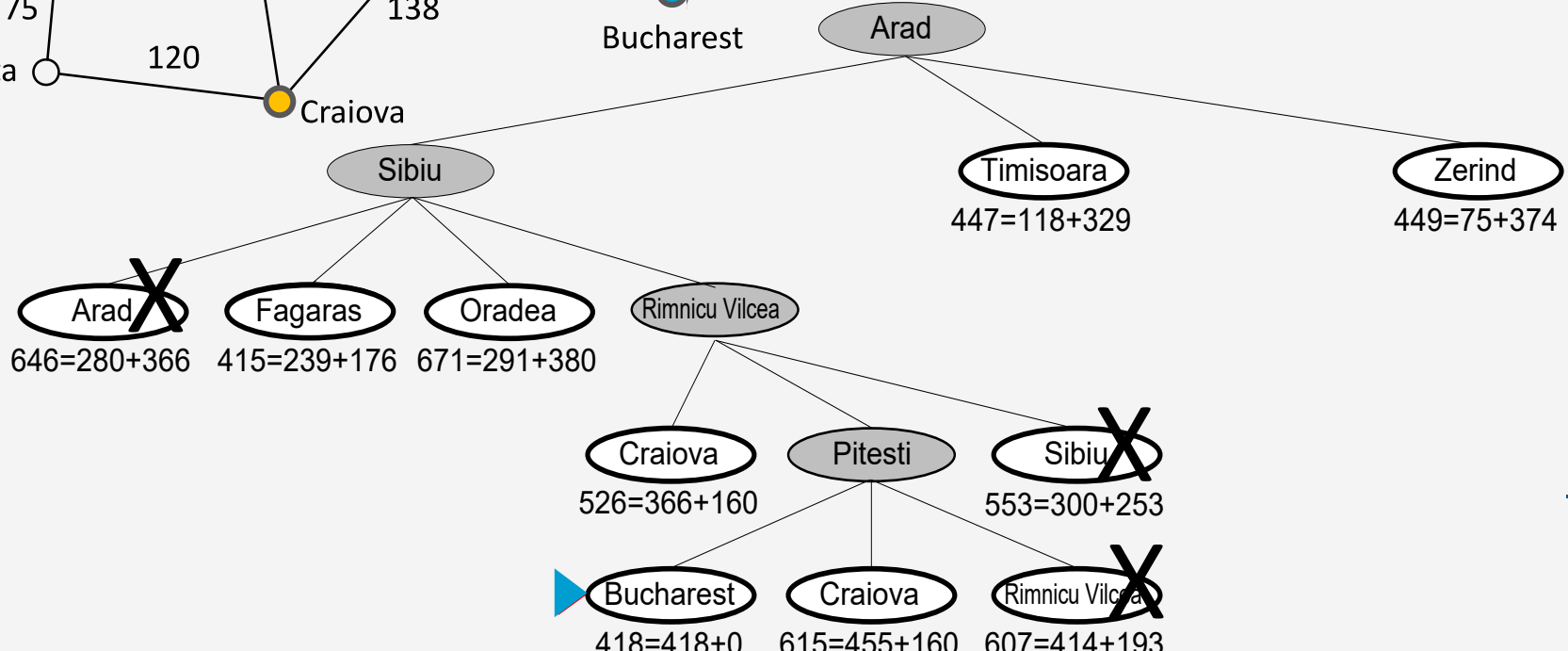
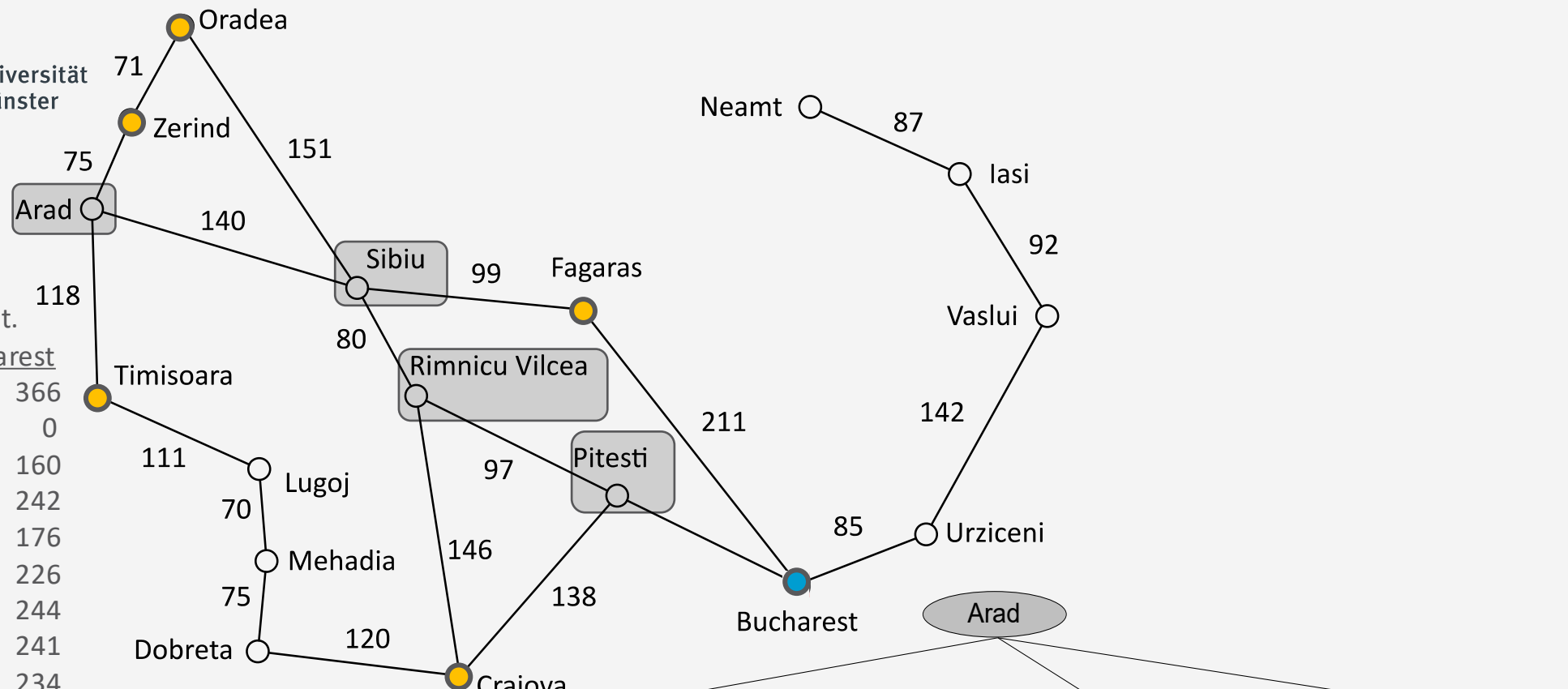

straight-line dist.  
from *s* to Bucharest

Arad	366
Bucharest	0
Craiova	160
Dobreta	242
Fagaras	176
Iasi	226
Lugoj	244
Mehadia	241
Neamt	234
Oradea	380
Pitesti	100
Rimnicu Vilcea	193
Sibiu	253
Timisoara	329
Urziceni	80
Vaslui	199
Zerind	374

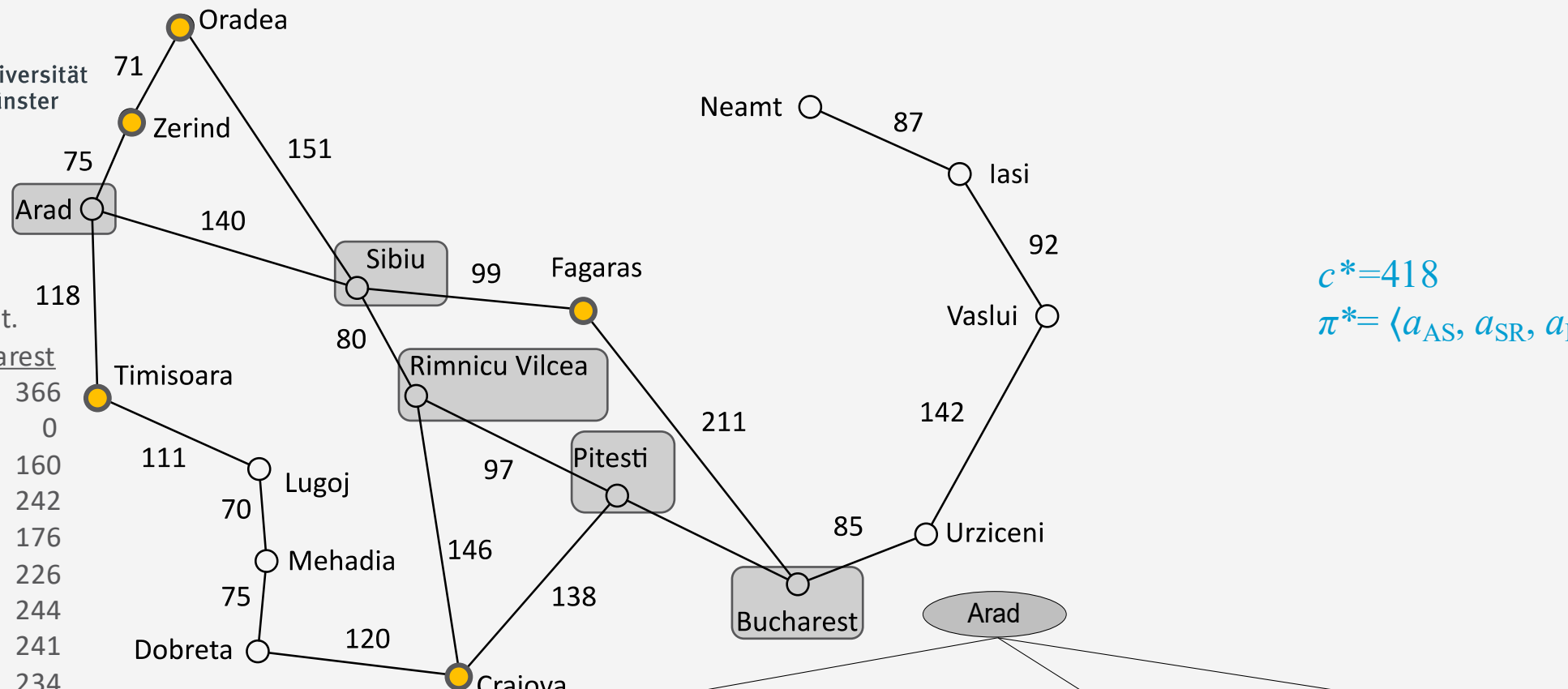

$c^*=418$   
 $\pi^* = \langle a_{AS}, a_{SR}, a_{RP}, a_{PB} \rangle$

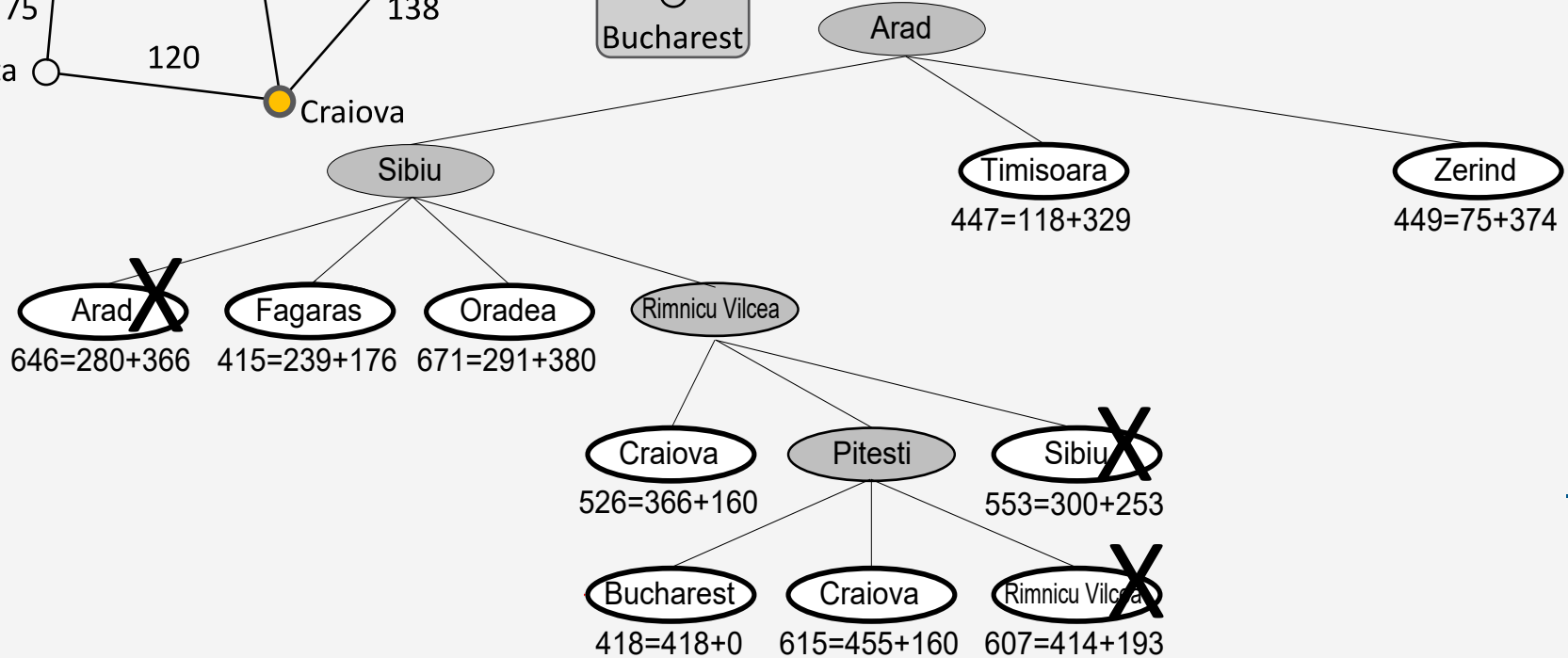

straight-line dist.  
from  $s$  to Bucharest

Arad	366
Bucharest	0
Craiova	160
Dobreta	242
Fagaras	176
Iasi	226
Lugoj	244
Mehadia	241
Neamt	234
Oradea	380
Pitesti	100
Rimnicu Vilcea	193
Sibiu	253
Timisoara	329
Urziceni	80
Vaslui	199
Zerind	374

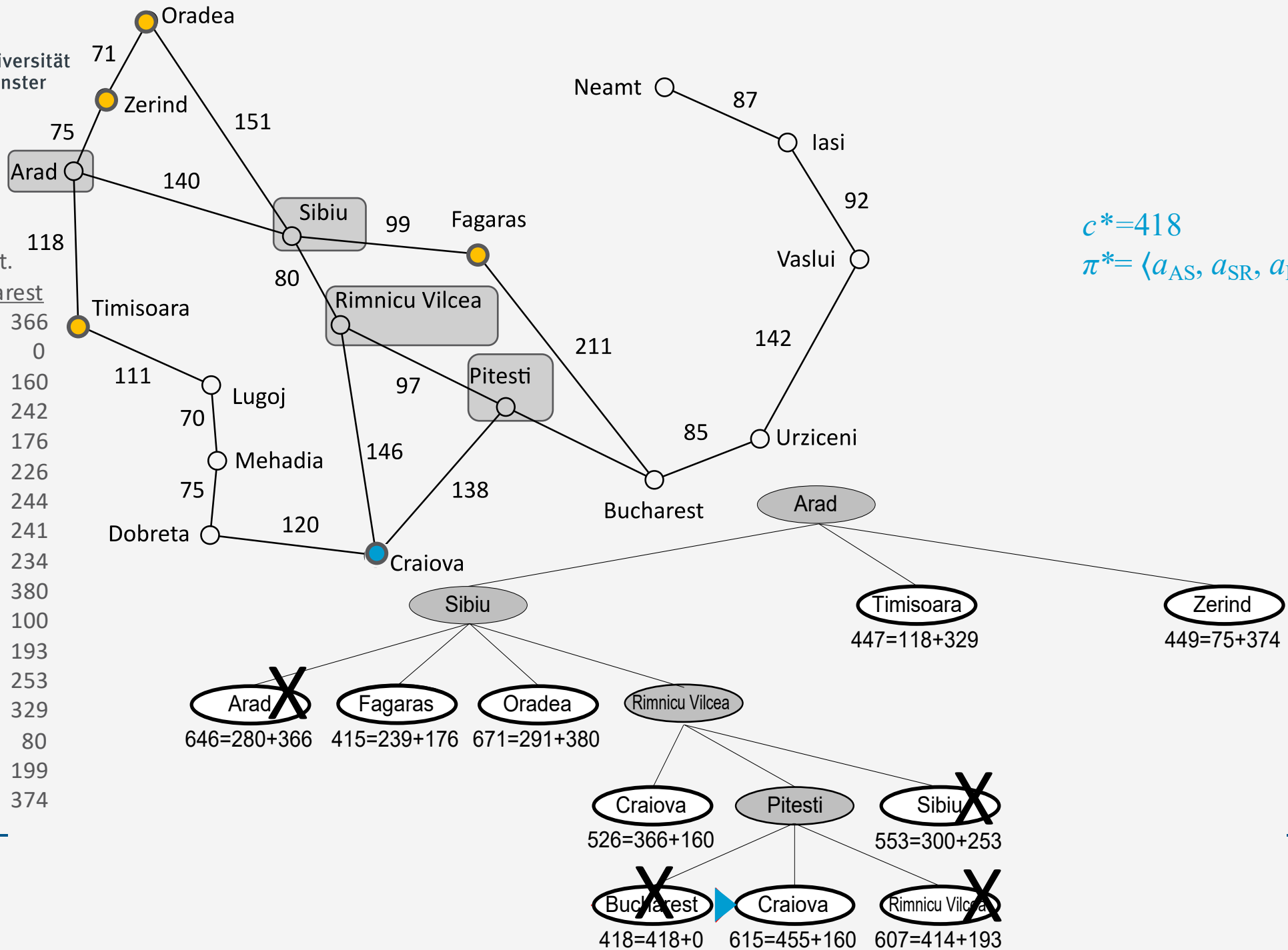

$$c^* = 418$$

$$\pi^* = \langle a_{AS}, a_{SR}, a_{RP}, a_{PB} \rangle$$

straight-line dist.  
from  $s$  to Bucharest

Arad	366
Bucharest	0
Craiova	160
Dobreta	242
Fagaras	176
Iasi	226
Lugoj	244
Mehadia	241
Neamt	234
Oradea	380
Pitesti	100
Rimnicu Vilcea	193
Sibiu	253
Timisoara	329
Urziceni	80
Vaslui	199
Zerind	374

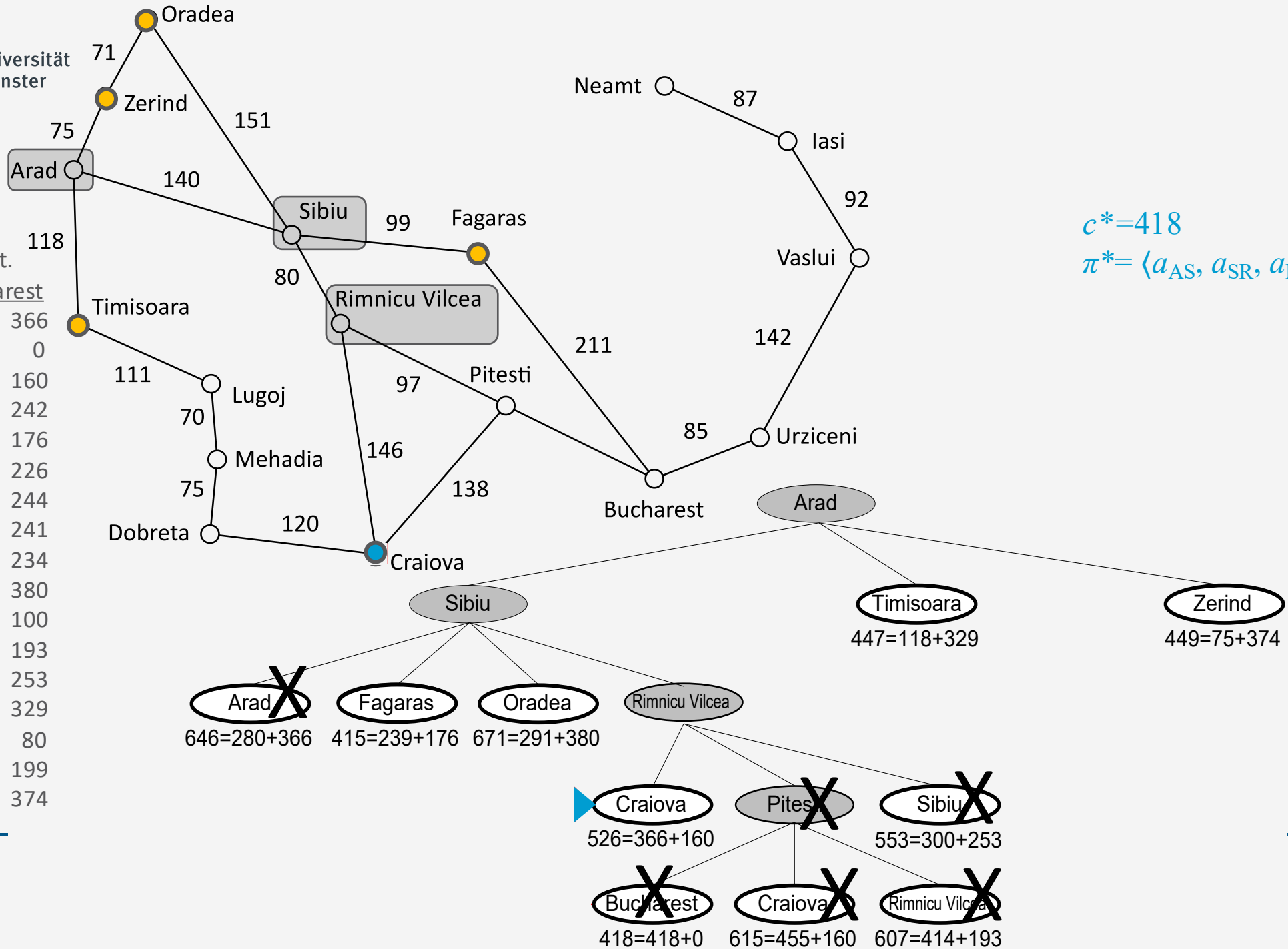

$$c^* = 418$$

$$\pi^* = \langle a_{AS}, a_{SR}, a_{RP}, a_{PB} \rangle$$

straight-line dist.  
from *s* to Bucharest

Arad	366
Bucharest	0
Craiova	160
Dobreta	242
Fagaras	176
Iasi	226
Lugoj	244
Mehadia	241
Neamt	234
Oradea	380
Pitesti	100
Rimnicu Vilcea	193
Sibiu	253
Timisoara	329
Urziceni	80
Vaslui	199
Zerind	374

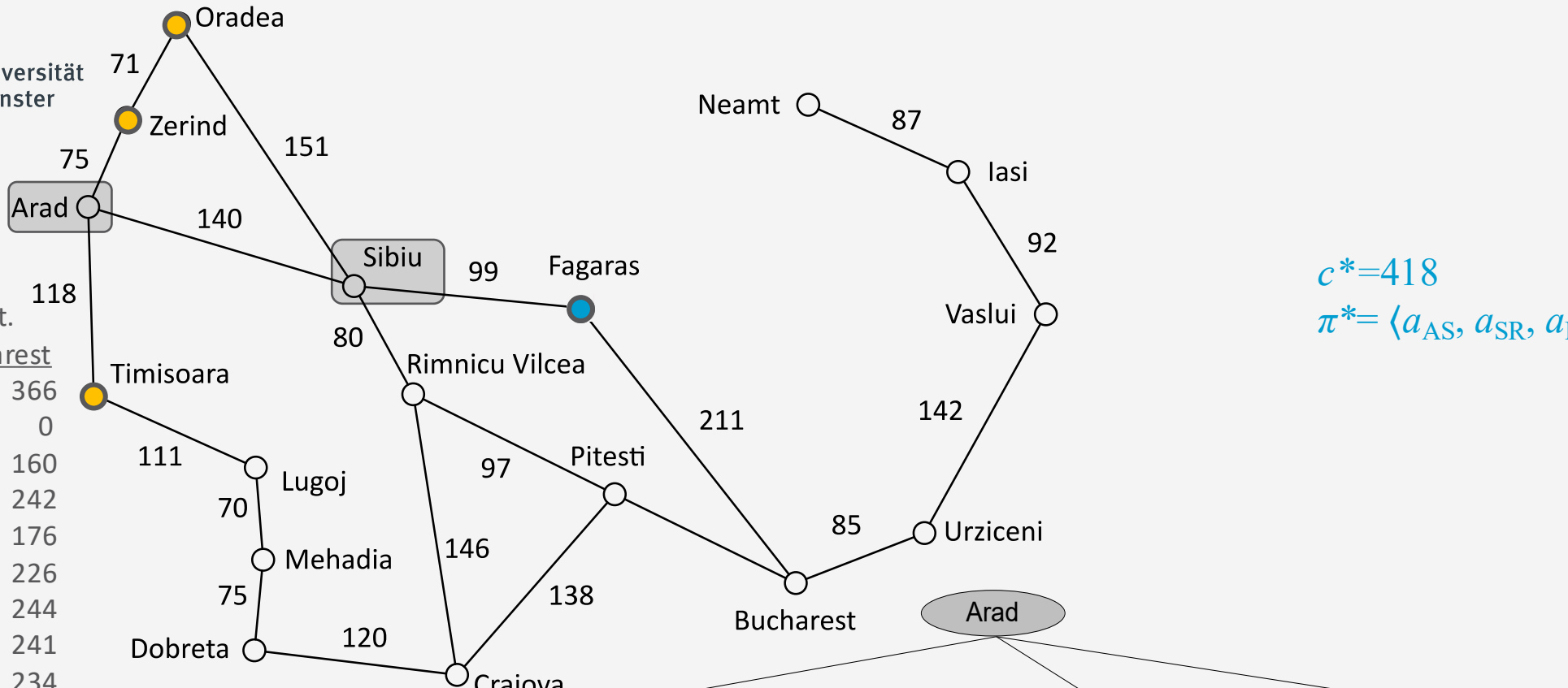

$$c^* = 418$$

$$\pi^* = \langle a_{AS}, a_{SR}, a_{RP}, a_{PB} \rangle$$

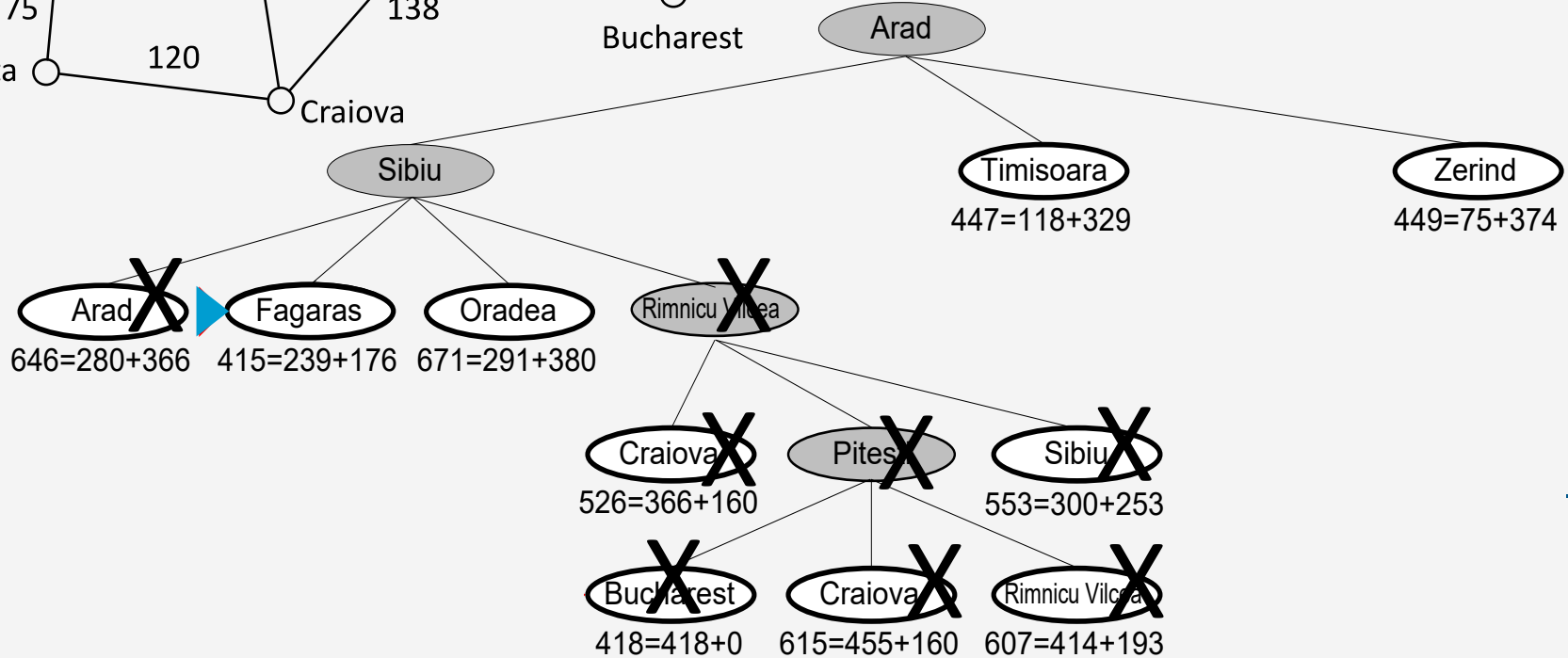

straight-line dist.  
from *s* to Bucharest

Arad	366
Bucharest	0
Craiova	160
Dobreta	242
Fagaras	176
Iasi	226
Lugoj	244
Mehadia	241
Neamt	234
Oradea	380
Pitesti	100
Rimnicu Vilcea	193
Sibiu	253
Timisoara	329
Urziceni	80
Vaslui	199
Zerind	374

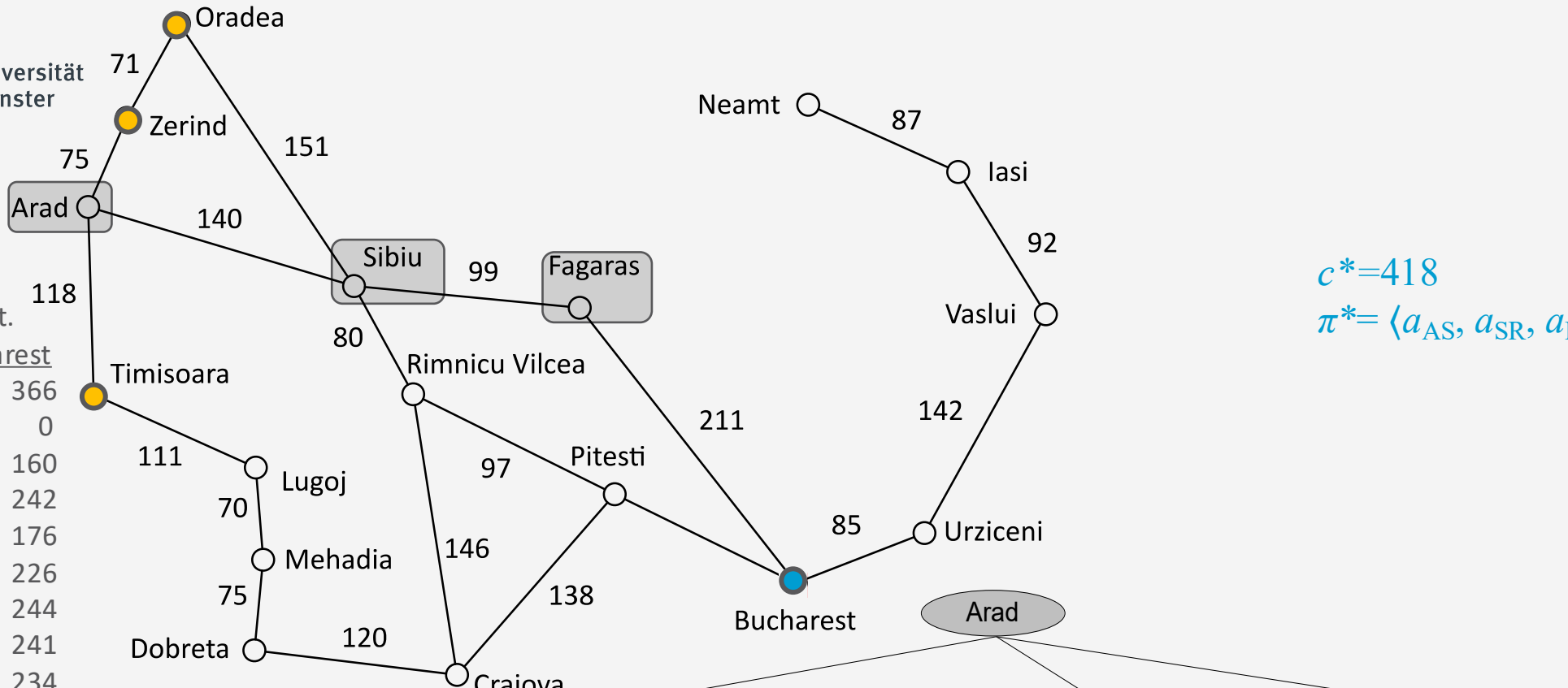

$$c^* = 418$$

$$\pi^* = \langle a_{AS}, a_{SR}, a_{RP}, a_{PB} \rangle$$

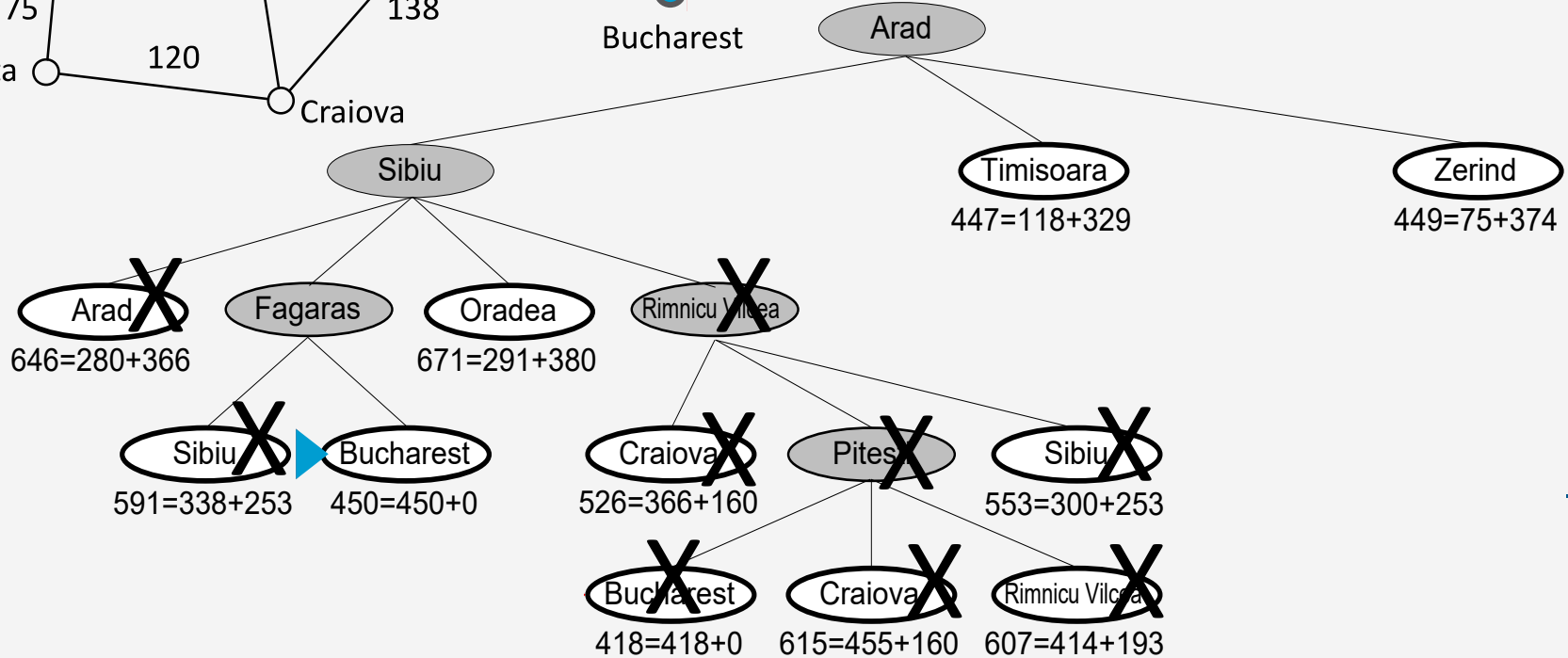

straight-line dist.  
from *s* to Bucharest

Arad	366
Bucharest	0
Craiova	160
Dobreta	242
Fagaras	176
Iasi	226
Lugoj	244
Mehadia	241
Neamt	234
Oradea	380
Pitesti	100
Rimnicu Vilcea	193
Sibiu	253
Timisoara	329
Urziceni	80
Vaslui	199
Zerind	374

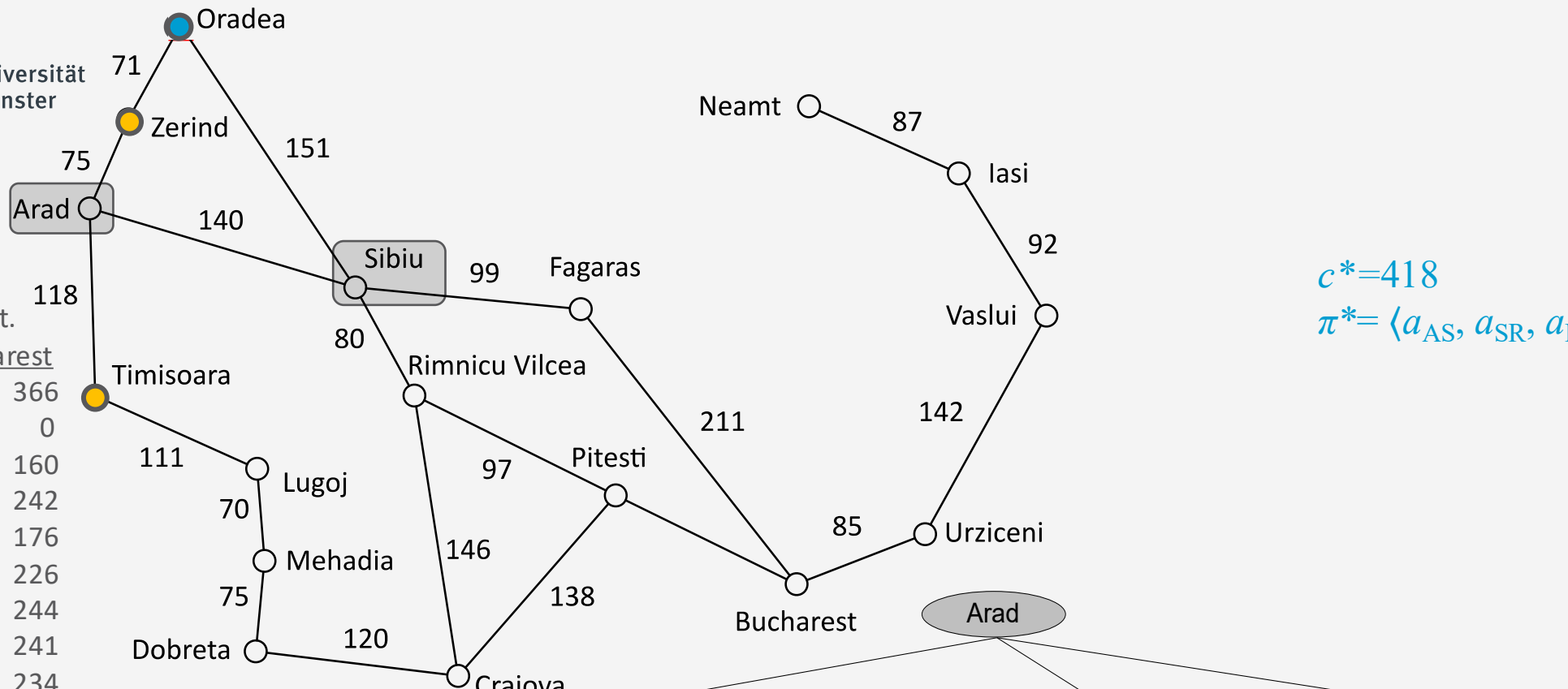

$$c^* = 418$$

$$\pi^* = \langle a_{AS}, a_{SR}, a_{RP}, a_{PB} \rangle$$

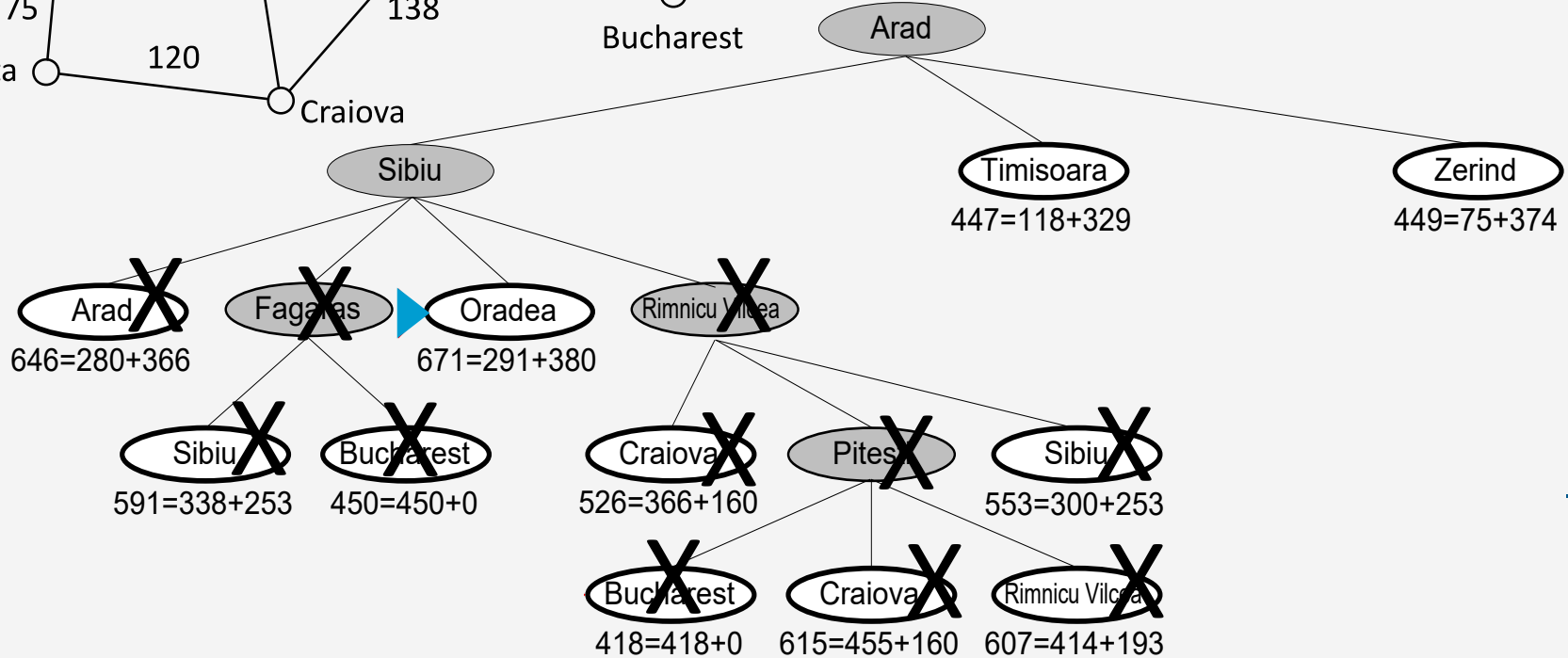

# Iterative Deepening Search (IDS)

- Example:
  - ( $k = 1$ ) Expand  $a$
  - ( $k = 2$ ) Expand  $a, b, c$
  - ( $k = 3$ ) Expand  $a, b, c, d, e, f, g$
  - ( $k = 4$ ) Expand  $a, b, c, d, e, f, g, h, i, j, k, l, m, n, o$ 
    - Solution path  $\langle a, c, g, o \rangle$
    - Total number of node expansions:  $1 + 3 + 7 + 15 = 26$
- If goal is at depth  $d$  and branching factor is 2:

$$\sum_{i=1}^d (2^i - 1) = \left( \sum_{i=1}^d 2^i \right) - d = 2^{d+1} - 2 - d = O(2^d)$$

- Generalisation: If goal is at depth  $d$  and branching factor is  $b$ :

$$\sum_{i=1}^d (b^i - 1) = \left( \sum_{i=1}^d b^i \right) - d = b^{d+1} - b - d = O(b^d)$$

```

IDS ( $\Sigma, s_0, g$ )
for  $k = 1$  to  $\infty$  do
   $\pi^* \leftarrow$  do DFS, backtracking at every
    node of depth  $k$ 
  if  $\pi^* \neq$  failure then
    return  $\pi^*$ 
  if the search generated
    no nodes of depth  $k$  then
    return failure
  
```

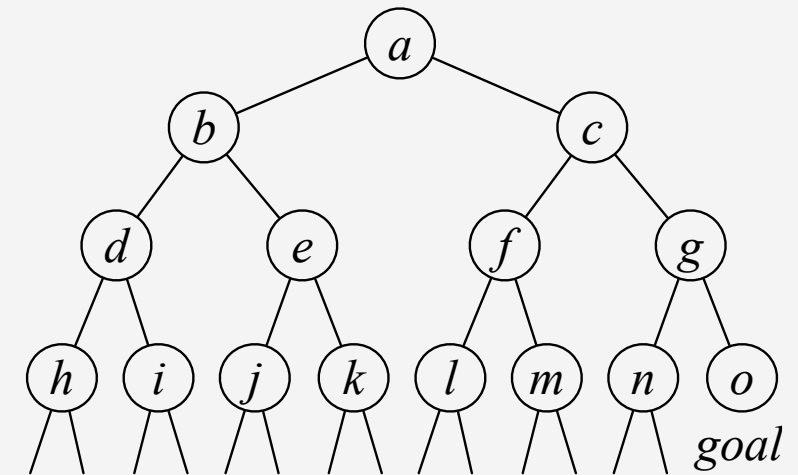

# Iterative Deepening Search (IDS)

- Properties
    - Termination, completeness, optimality
      - Same as BFS
    - Worst-case complexity
      - Memory requirement  $O(bd)$ 
        - vs.  $O(b^d)$  with BFS
      - Worst-case running time  $O(b^d)$ 
        - vs.  $O(b^l)$  for DFS
        - If the number of nodes at depth  $d$  grows exponentially with  $d$
- where
- $b$  = max branching factor
  - $d$  = min solution depth if there is one, otherwise max depth of any node

```

IDS ( $\Sigma, s_0, g$ )
for  $k = 1$  to  $\infty$  do
   $\pi^* \leftarrow$  do DFS, backtracking at every
    node of depth  $k$ 
  if  $\pi^* \neq$  failure then
    return  $\pi^*$ 
  if the search generated
    no nodes of depth  $k$  then
    return failure
  
```

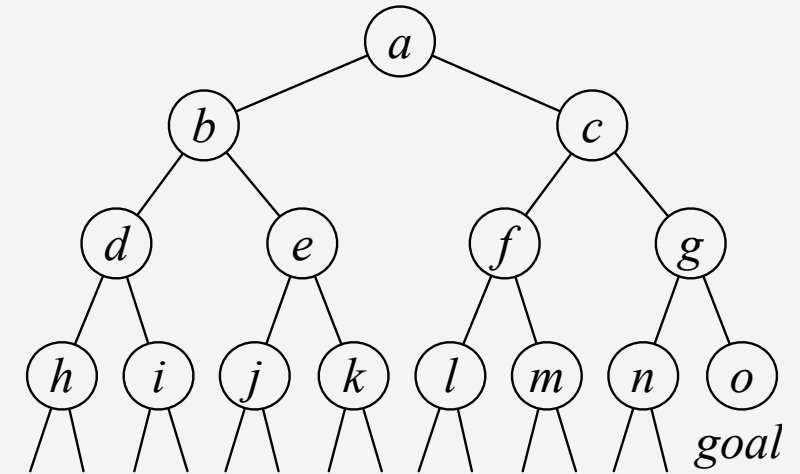

## IDA\*

- Basically A\* + IDS: Not using path length but  $f(v)$ , i.e., estimated cost, as cut-off criterion of IDS
- Properties
  - Termination, completeness, and optimality same as A\*
  - Worst-case complexity
    - If  $h$  admissible, memory requirement  $O(bd)$  instead of  $O(b^d)$
    - If number of nodes grows exponentially with  $c$ , running time  $O(b^d)$ 
      - Can be much worse if the number of nodes grows subexponentially
      - e.g., real-valued costs
- IDA\* is not much used in practice

```

IDA* ( $\Sigma, s_0, g$ )
 $c \leftarrow 0$ 
loop
   $\pi^* \leftarrow$  do DFS, backtracking
                whenever  $f(v) > c$ 
  if  $\pi^* \neq$  failure then
    return  $\pi^*$ 
  if DFS didn't generate
    an  $f(v) > c$  then
    return failure
   $c \leftarrow$  the smallest  $f(v) > c$ 
                where backtracking occurred
  
```

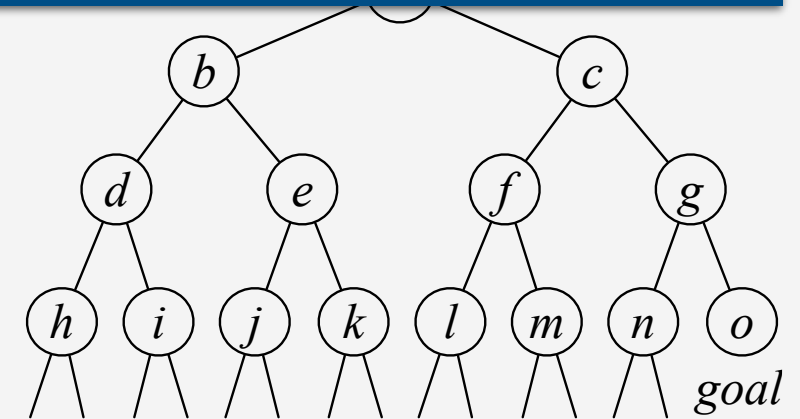

## Discussion

- If  $h$  is admissible, both  $A^*$  and DFBB will return optimal solutions
  - Usually DFBB takes more time,  $A^*$  takes more memory
  - $A^*$  better than DFBB in highly connected graphs (many paths to states)
    - DFBB can have exponentially worse running time than  $A^*$
  - DFBB best in problems where  $S$  is a tree of uniform height + all solutions at the bottom (e.g., constraint satisfaction)
    - DFBB and  $A^*$  have similar running time
    - $A^*$  takes exponentially more memory than DFBB
- DFS returns the first solution it finds
  - Less backtracking than DFBB, but solution can be very far from optimal
- GBFS returns the first solution it finds
  - With a good heuristic function, usually near-optimal without much backtracking
  - Used by most classical planners nowadays

## Intermediate Summary

- Forward-search, Deterministic-Search
- Cycle-checking
- Breadth-first, depth-first, uniform-cost search
- A\*, GBFS, DFBB
- IDS, IDA\*

## Outline per the Book

### 2.1 *State-variable representation*

- State = {values of variables}; action = changes to those values

### 2.2 *Forward state-space search*

- Start at initial state, look for sequence of actions that achieve goal

### 2.3 *Heuristic functions*

- How to guide a forward state-space search

### 2.6 *Incorporating planning into an actor*

- Online lookahead, unexpected events

### 2.4 *Backward search*

- Start at goal state, go backwards toward initial state

### 2.5 *Plan-space search*

- Start with incomplete plan for getting from initial state to goal state, make transformations to fix flaws in the plan

# Heuristic Functions

- Planning problem  $P$  in domain  $\Sigma$
- Creating a heuristic function:
  - Weaken some of the constraints that
    - Restrict what the states, actions, and plans are
    - Restrict when an action or plan is applicable, what goals it achieves
    - Increase the costs of actions and plans
  - **Relaxed** planning domain  $\Sigma' = (S', A', \gamma')$  and problem  $P' = (\Sigma', s'_0, g')$ 
    - For every solution  $\pi$  for  $P$ ,  $P'$  has a solution  $\pi'$  with  $cost'(\pi') \leq cost(\pi)$
  - Suppose we have an algorithm  $A$  for solving planning problems in  $\Sigma'$ 
    - Heuristic function  $h^A(s)$  for  $P$ :
      - Find a solution  $\pi'$  for  $(\Sigma', s, g')$ ; return  $cost(\pi')$
    - If  $A$  runs quickly, then  $h^A$  may be a useful heuristic function
    - If  $A$  always finds optimal solutions, then  $h^A$  is admissible

## Example from A\*

- Relaxation: let vehicle travel in a straight line between any pair of cities
  - Straight-line-distance  $\leq$  distance by road

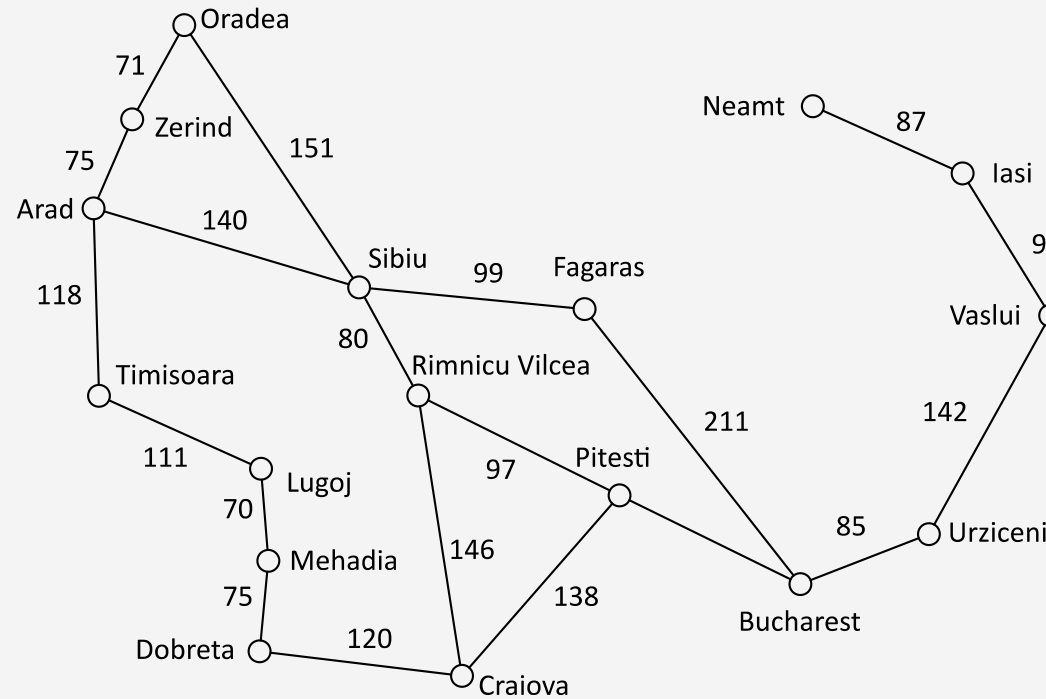

straight-line dist. from <i>s</i> to Bucharest	
Arad	366
Bucharest	0
Craiova	160
Dobreta	242
Fagaras	176
Iasi	226
Lugoj	244
Mehadia	241
Neamt	234
Oradea	380
Pitesti	100
Rimnicu Vilcea	193
Sibiu	253
Timisoara	329
Urziceni	80
Vaslui	199
Zerind	374

## Domain-independent Heuristics

- Heuristic functions that can be used work in any classical planning problem
  - Additive-cost heuristics
  - Max-cost heuristics
  - Delete-relaxation heuristics
    - Optimal relaxed solution
    - Fast-forward heuristics
  - Landmark heuristics

In the book, but I will skip them

## Delete-Relaxation

- Relaxation: State variable can have multiple values at a time
  - When assigning a new value, keep the old one too
  - Suppose state  $s$  includes an atom  $x = v$ , action  $a$  has effect  $x \leftarrow w$ 
    - $\gamma^+(s, a)$  is a **relaxed state** that includes both  $x = v$  and  $x = w$
- Example
  - $s_0 = \{loc(r1) = d3, cargo(r1) = nil, loc(c1) = d1\}$
  - $move(r1, d3, d1)$ 
    - Pre:  $loc(r1) = d3$
    - Eff:  $loc(r1) \leftarrow d1$
  - $\hat{s}_1 = \gamma^+(s_0, move(r1, d3, d1)) = \{loc(r1) = d3, loc(r1) = d1, cargo(r1) = nil, loc(c1) = d1\}$

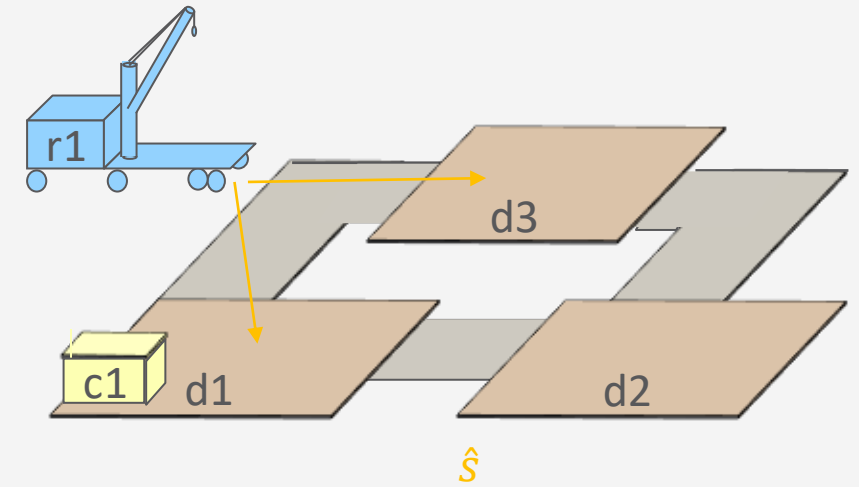
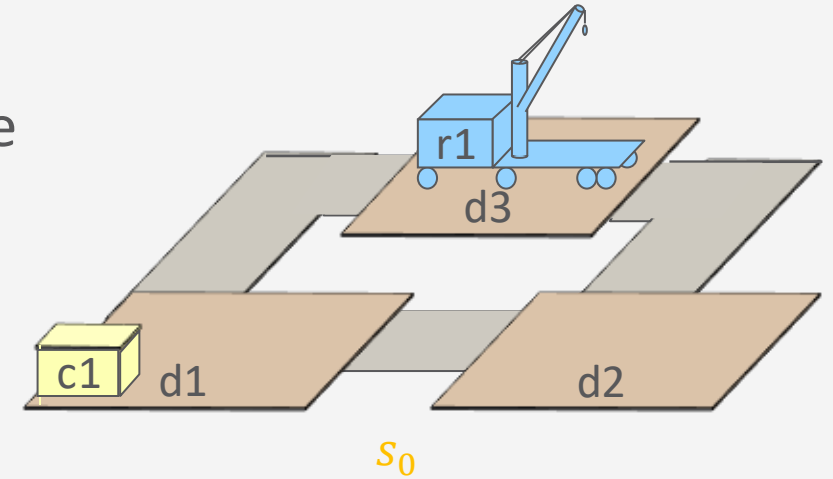

## Relaxed States

- **Relaxed state** (or *r-state*):
  - Set  $\hat{s}$  of ground atoms that includes at least one value for each state variable
  - Represents {all states that are subsets of  $\hat{s}$ }
  - Note: every state  $s$  is also a relaxed state that represents  $\{s\}$
- Examples
  - $\hat{s}_1 = \{loc(r1) = d1, loc(r1) = d3, cargo(r1) = nil, loc(c1) = d1\}$
  - $\hat{s}_2 = \gamma^+(\hat{s}_1, take(r1, d1, c1)) = \{loc(r1) = d1, loc(r1) = d3, cargo(r1) = nil, loc(c1) = r1, loc(c1) = d1, cargo(r1) = c1\}$

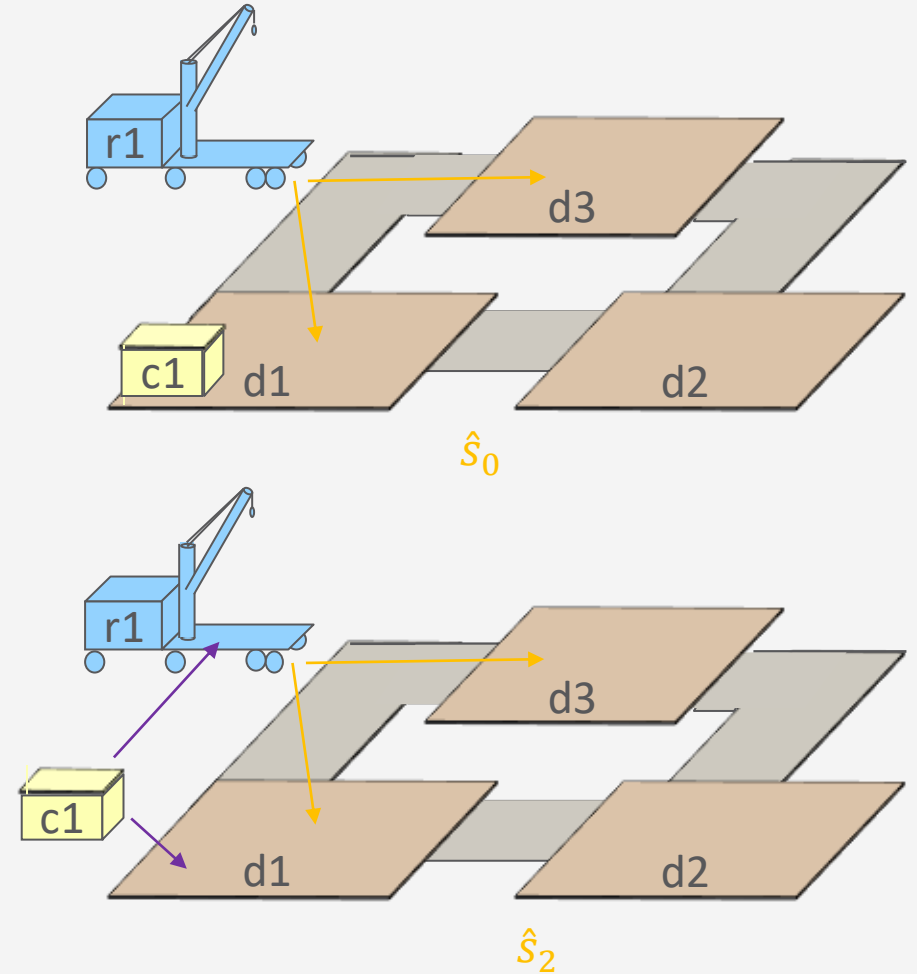

## R-applicability

- An r-state  $\hat{s}$  **r-satisfies** a set of literals  $g$  if a set  $s \subseteq \hat{s}$  satisfies  $g$
- Action  $a$  is **r-applicable** in  $\hat{s}$  if  $\hat{s}$  r-satisfies  $pre(a)$ 
  - i.e.,  $\hat{s}$  contains a subset  $s$  that satisfies the preconditions of  $a$
  - If  $a$  is r-applicable, then  $\gamma^+(\hat{s}, a) = \hat{s} \cup \gamma(s, a)$
- $\pi = \langle a_1, \dots, a_n \rangle$  is **r-applicable** in  $\hat{s}_0$  if there are r-states  $\hat{s}_1, \hat{s}_2, \dots, \hat{s}_n$  such that
  - $a_1$  is r-applicable in  $\hat{s}_0$  and  $\gamma^+(\hat{s}_0, a_1) = \hat{s}_1$
  - $a_2$  is r-applicable in  $\hat{s}_1$  and  $\gamma^+(\hat{s}_1, a_2) = \hat{s}_2$
  - ...
  - $a_n$  is r-applicable in  $\hat{s}_{n-1}$  and  $\gamma^+(\hat{s}_{n-1}, a_n) = \hat{s}_n$
- In this case,  $\gamma^+(\hat{s}_{n-1}, \pi) = \hat{s}_n$

## Example

- $s_0 = \{loc(r1) = d3, cargo(r1) = nil, loc(c1) = d1\}$ 
  - $move(r1, d3, d1)$ 
    - Pre:  $loc(r1) = d3$
    - Eff:  $loc(r1) \leftarrow d1$
- $\hat{s}_1 = \gamma^+(\hat{s}_1, move(r1, d1, c1)) = \{loc(r1) = d1, loc(r1) = d3, cargo(r1) = nil, loc(c1) = d1\}$ 
  - $take(r, l, c)$ 
    - pre:  $cargo(r) = nil, loc(r) = l, loc(c) = l$
    - eff:  $cargo(r) \leftarrow c, loc(c) \leftarrow r$
- $\hat{s}_2 = \gamma^+(\hat{s}_1, take(r1, d1, c1))$   
 $= \{loc(r1) = d1, loc(r1) = d3, cargo(r1) = nil, loc(c1) = r1, loc(c1) = d1, cargo(r1) = c1\}$

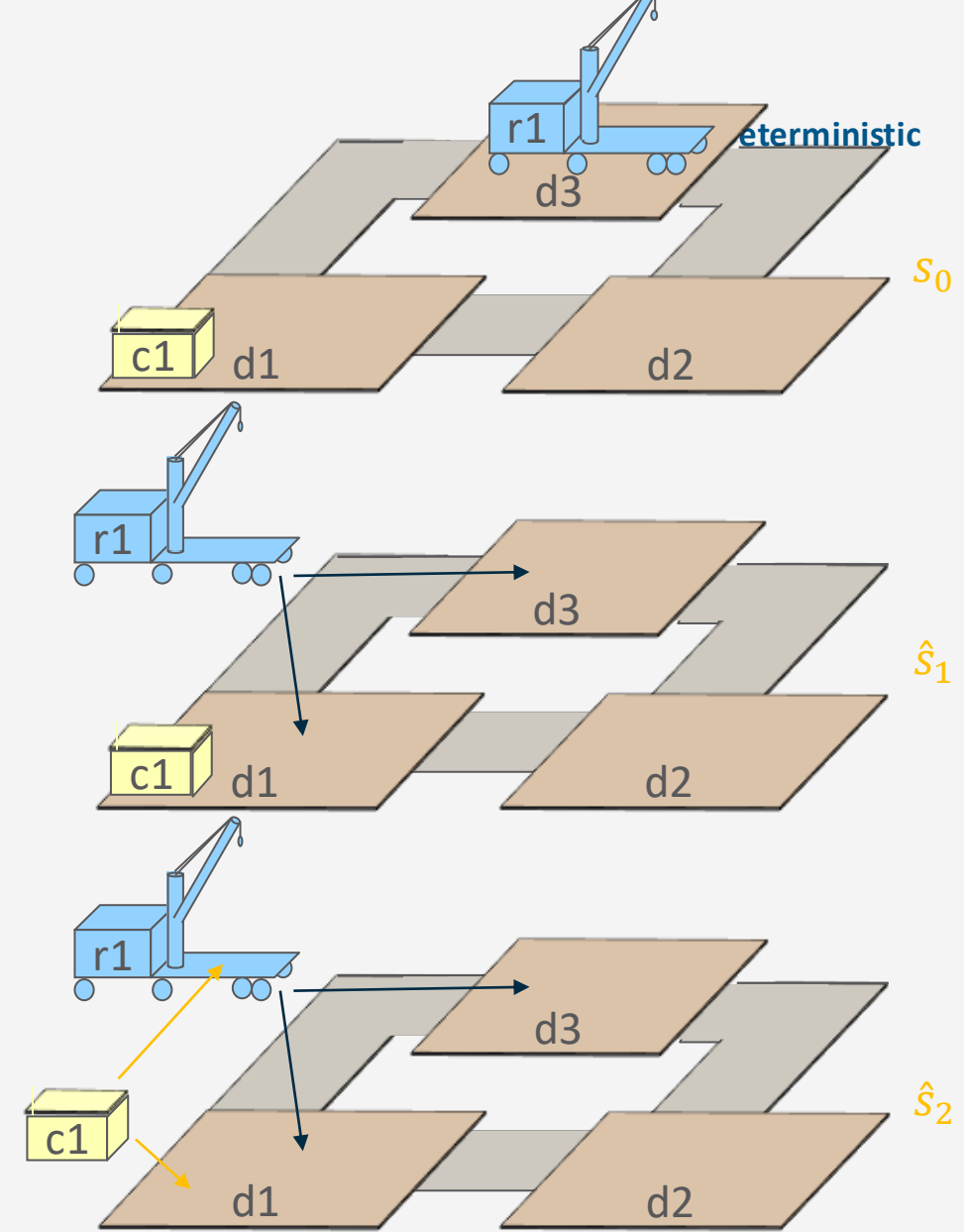

## Relaxed Solution

- Planning problem  $P = (\Sigma, s_0, g)$
- Plan  $\pi$  is a **relaxed solution** for  $P$  if  $\gamma^+(\hat{s}_0, \pi)$  r-satisfies  $g$
- Example:
  - Initial  $s_0 = \{loc(r1) = d3, cargo(r1) = nil, loc(c1) = d1\}$
  - Goal states  $g = \{loc(r1) = d3, loc(c1) = r1\}$
  - Plan  $\pi = \langle move(r1, d3, d1), take(r1, c1, d1) \rangle$
- End state  $\gamma^+(s_0, \pi)$   
 $= \{loc(r1) = d1, loc(r1) = d3, cargo(r1) = nil,$   
 $loc(c1) = r1, loc(c1) = d1, cargo(r1) = c1\}$

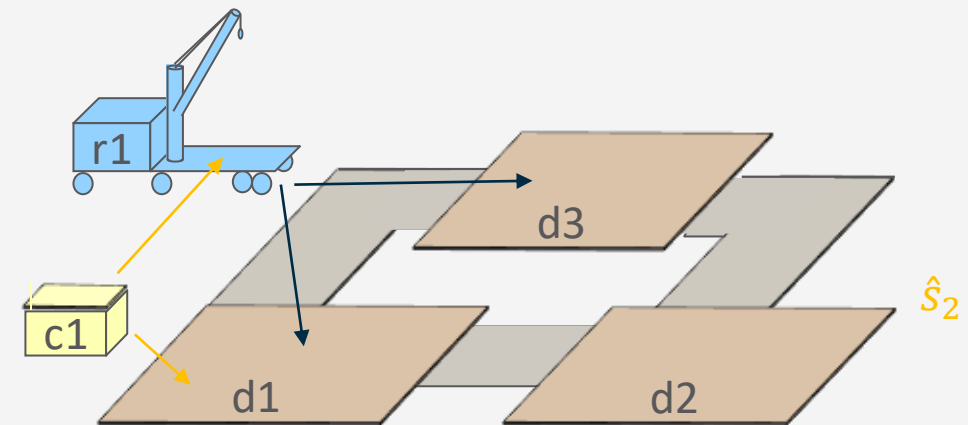
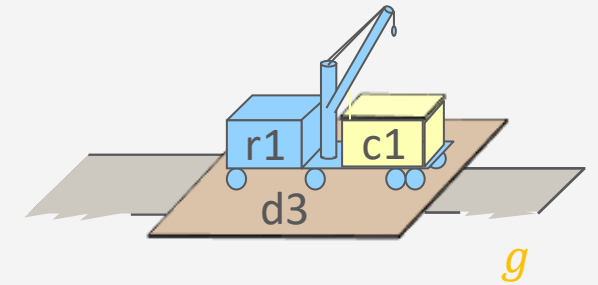
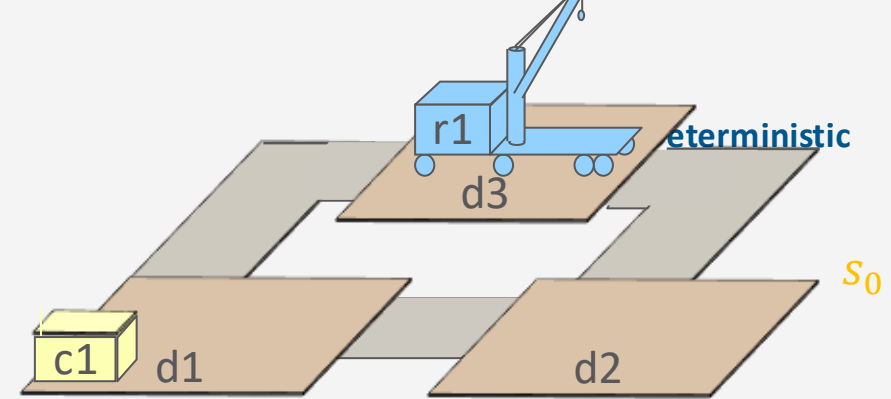

## Optimal Relaxed Solution Heuristics

- Given a planning problem  $P = (\Sigma, s_0, g)$
- **Optimal relaxed solution heuristics:**
  - $h^+(s) =$  minimum cost of all relaxed solutions for  $P$
- Example:
  - Initial  $s_0 = \{loc(r1) = d3, cargo(r1) = nil, loc(c1) = d1\}$
  - Goal states  $g = \{loc(r1) = d3, loc(c1) = r1\}$
  - $\pi = \langle move(r1, d3, d1), take(r1, c1, d1) \rangle$ 
    - $cost(\pi) = 2$
  - No less-costly relaxed solution, so  $h^+(s_0) = 2$

How does this compare with  $h^*(s)$ ?

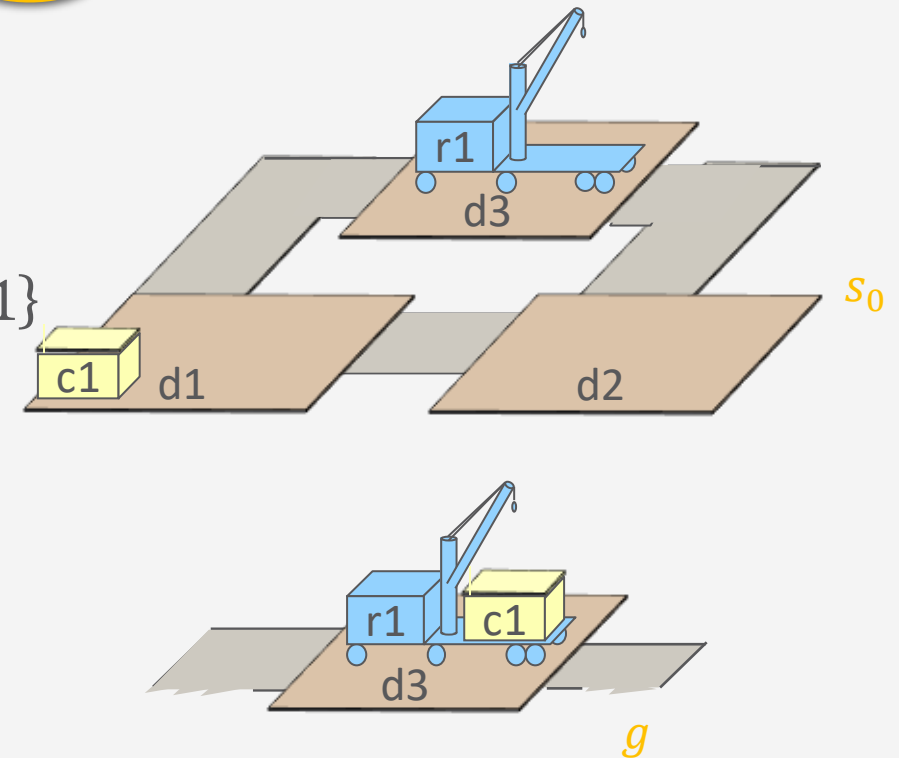

## Example

- $s_0 = \{loc(r1) = d3, cargo(r1) = nil, loc(c1) = d1\}$
- In  $s_0$ , two applicable actions
  - $a_1 = move(r1, d3, d1)$ 
    - $s_1 = \{loc(r1) = d1, cargo(r1) = nil, loc(c1) = d1\}$
  - $a_2 = move(r1, d3, d2)$ 
    - $s_2 = \{loc(r1) = d2, cargo(r1) = nil, loc(c1) = d1\}$
- GBFS evaluates  $h^+(s_1)$  and  $h^+(s_2)$ , and chooses to move to whichever is smaller

What are  $h^+(s_1)$  and  $h^+(s_2)$  and where does GBFS move?

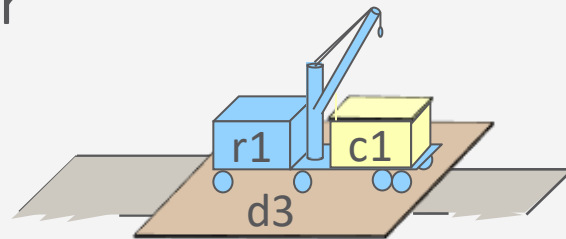

$g = \{loc(r1) = d3, loc(c1) = r1\}$

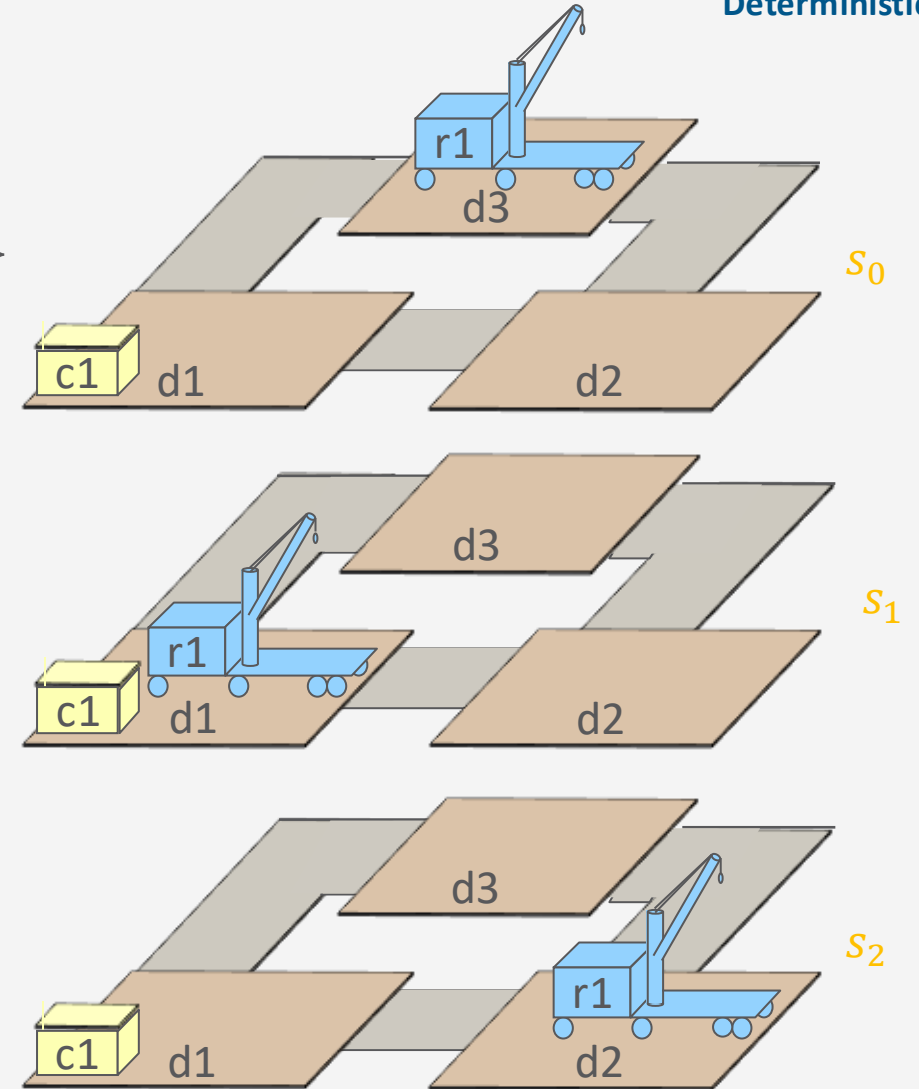

## Fast-Forward Heuristics

- Every state is also a relaxed state
- Every solution is also a relaxed solution
- $h^+(s)$  = minimum cost of all relaxed solutions
  - Thus  $h^+$  is admissible
  - Problem: computing it is **NP-hard**
- Fast-Forward Heuristics  $h^{FF}$ 
  - An approximation of  $h^+$  that is easier to compute
    - Upper bound on  $h^+$
  - Name comes from a planner called *Fast Forward*

## Preliminaries

- Let  $A_1$  be a set of actions that are r-applicable in  $\hat{s}$ 
  - Can **apply** them **in any order** and get **same result**
  - Define result of applying  $A_1$  in  $\hat{s}$  as

$$\gamma^+(\hat{s}, A_1) = \hat{s} \cup \bigcup_{a \in A_1} \text{eff}(a)$$

- Let  $\hat{s}_1 = \gamma^+(\hat{s}_0, A_1)$ 
  - Suppose  $A_2$  is a set of actions that are r-applicable in  $\hat{s}_1$
  - Define  $\gamma^+(\hat{s}_0, \langle A_1, A_2 \rangle) = \gamma^+(\hat{s}_1, A_2)$
  - ...
  - Define  $\gamma^+(\hat{s}_0, \langle A_1, A_2, \dots, A_n \rangle)$  in the obvious way

## Fast-Forward Heuristics

- Find a minimal relaxed solution and return its cost
  - Input: planning problem  $(\Sigma, s, g)$
  - Generates a sequence of successively larger  $r$ -states and sets of applicable actions until  $\hat{s}_k$   $r$ -satisfies  $g$ :  
 $\hat{s}_0, A_1, \hat{s}_1, A_2, \hat{s}_2, \dots, A_{k-1}, \hat{s}_{k-1}, A_k, \hat{s}_k$ 
    - Extract minimal relaxed solution from that sequence
  - Return value is ambiguous
    - Each  $\hat{a}_i$  in  $h^{FF}(s)$  is a minimal set of actions s.t.  $\gamma^+(\hat{s}_{i-1}, \hat{a}_i)$   $r$ -satisfies  $pre(\hat{a}_i)$
    - Depends on *which* minimal subsets chosen

```

HFF ( $\Sigma, s, g$ )
  // construct a relaxed solution  $\langle A_1, A_2, \dots, A_k \rangle$ :
   $\hat{s}_0 \leftarrow s$ 
  for  $k = 1; k++$ ; a subset of  $\hat{s}_k$   $r$ -satisfies  $g$  do
     $A_k = \{\text{all actions } r\text{-applicable in } \hat{s}_{k-1}\}$ 
     $\hat{s}_k = \gamma^+(s_{k-1}, A_k)$ 
    if  $k > 1$  and  $\hat{s}_k = \hat{s}_{k-1}$  then
      return  $\infty$  // there is no solution
  // extract minimal relaxed solution  $\langle \hat{a}_1, \hat{a}_2, \dots, \hat{a}_k \rangle$ :
   $\hat{g}_k = g$ 
  for  $i = k$  down to 1 do
     $\hat{a}_i = \text{any minimal subset of } A_i$ 
      such that  $\gamma^+(\hat{s}_{i-1}, \hat{a}_i)$   $r$ -satisfies  $\hat{g}_i$ 
     $\hat{g}_{i-1} \leftarrow (\hat{g}_i \setminus \text{eff}(\hat{a}_i)) \cup \text{pre}(\hat{a}_i)$ 
   $\hat{\pi} \leftarrow \langle \hat{a}_1, \dots, \hat{a}_k \rangle$ 
  return  $\sum_{a \text{ is an action in } \hat{\pi}} \text{cost}(a)$  // upper bound on  $h^+$ 

```

Define  $h^{FF}(s) := \text{value returned by HFF}(\Sigma, s, g)$

## Example (as before)

- $s_0 = \{loc(r1) = d3, cargo(r1) = nil, loc(c1) = d1\}$
- In  $s_0$ , two applicable actions
  - $a_1 = move(r1, d3, d1)$ 
    - $s_1 = \{loc(r1) = d1, cargo(r1) = nil, loc(c1) = d1\}$
  - $a_2 = move(r1, d3, d2)$ 
    - $s_2 = \{loc(r1) = d2, cargo(r1) = nil, loc(c1) = d1\}$
- GBFS using  $h^{FF}$ 
  - Compute  $h^{FF}(s_1)$  and  $h^{FF}(s_2)$
  - Move to whichever is smaller

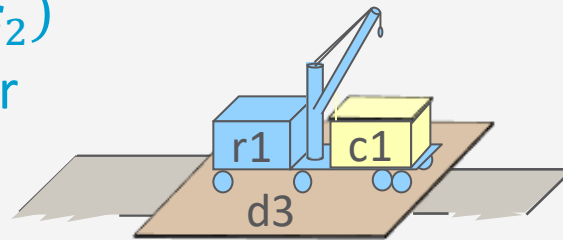

$$g = \{loc(r1) = d3, loc(c1) = r1\}$$

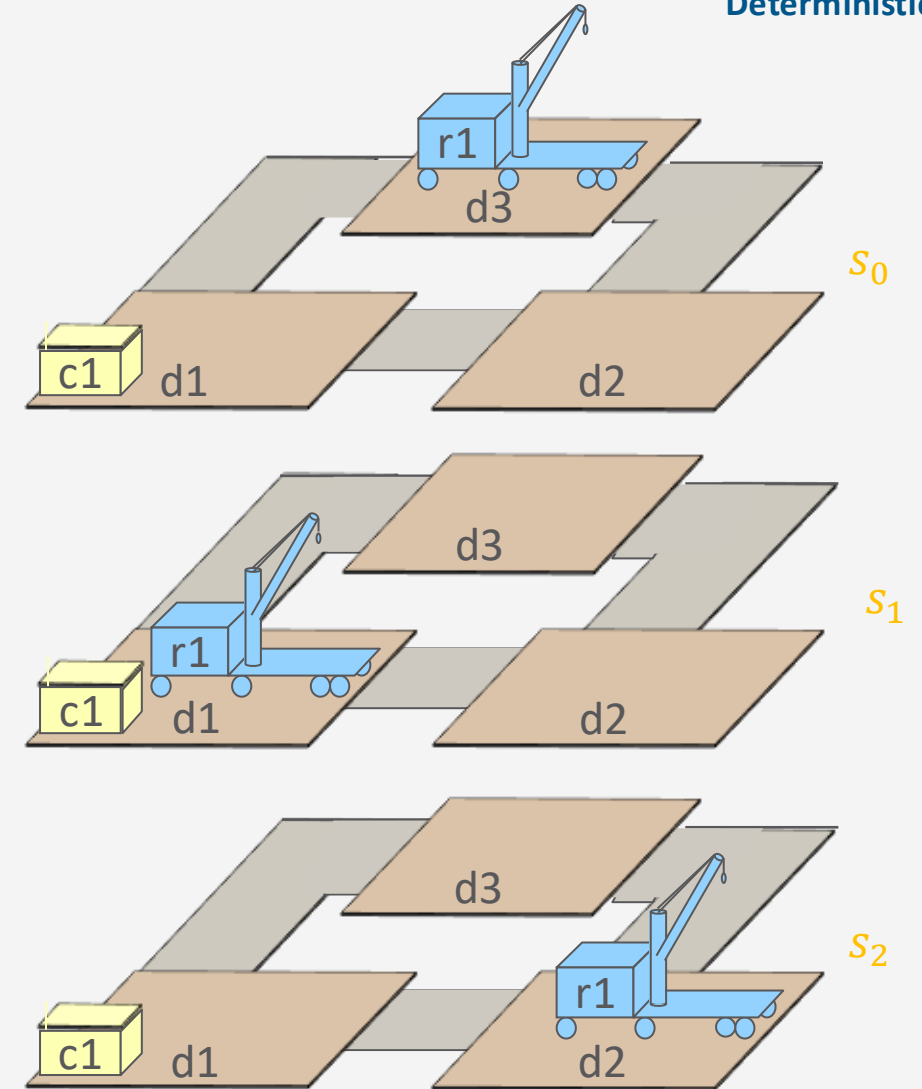

# Example

```

// construct a relaxed solution  $\langle A_1, A_2, \dots, A_k \rangle$ :
 $\hat{s}_0 \leftarrow s$ 
for  $k = 1; k++$ ; subset of  $\hat{s}_k$  r-satisfies  $g$  do
   $A_k = \{\text{all actions r-applicable in } \hat{s}_{k-1}\}$ 
   $\hat{s}_k = \gamma^+(s_{k-1}, A_k)$ 
  if  $k > 1$  and  $\hat{s}_k = \hat{s}_{k-1}$  then
    return  $\infty$  // there is no solution
  
```

Deterministic

Relaxed Planning Graph (RPG) from  $\hat{s}_0 = s_1$  to  $g$   
(solid lines indicate preconditions/effects):

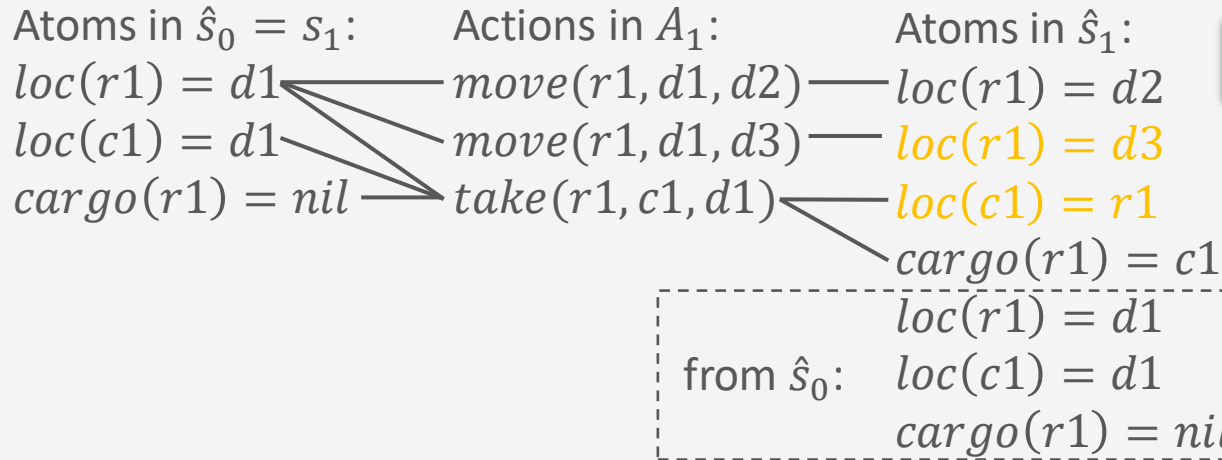

$\langle A_1 \rangle$  is a relaxed solution

$\gamma^+(s_0, A_1)$  r-satisfies  $g$

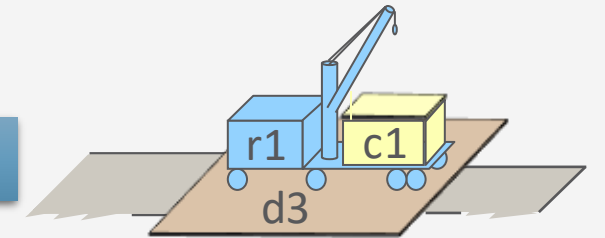

$g = \{loc(r1) = d3, loc(c1) = r1\}$

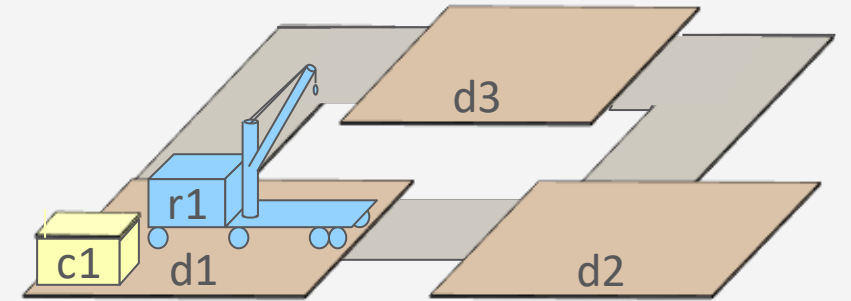

$s_1 = \{loc(r1) = d1, cargo(r1) = nil, loc(c1) = d1\}$

# Example

```
// extract minimal relaxed solution
```

```
 $\hat{g}_k = g$ 
```

```
for  $i = k$  down to 1 do
```

```
   $\hat{a}_i =$  minimal subset of  $A_i$  s.t.  $\gamma^+(\hat{s}_{i-1}, \hat{a}_i)$  r-satisfies  $\hat{g}_i$ 
```

```
   $\hat{g}_{i-1} \leftarrow (\hat{g}_i \setminus \text{eff}(\hat{a}_i)) \cup \text{pre}(\hat{a}_i)$ 
```

Deterministic

Relaxed Planning Graph (RPG) from  $\hat{s}_0 = s_1$  to  $g$   
 (follow lines from atoms in  $g$ : all if precond.; one if eff.)

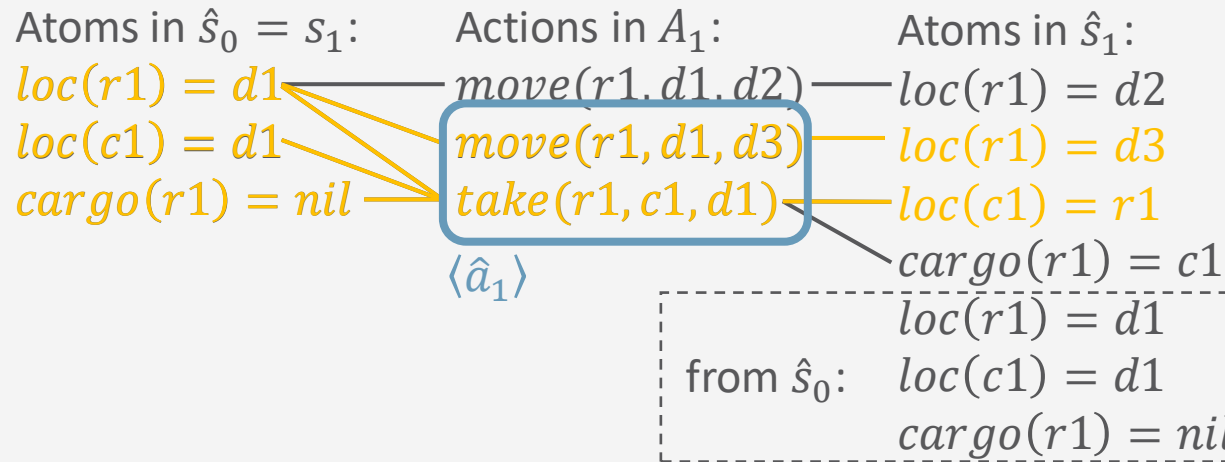

- $\langle \hat{a}_1 \rangle$  is a minimal relaxed solution
- Cost of each action is 1, so  $h^{FF}(s_1) = 2$

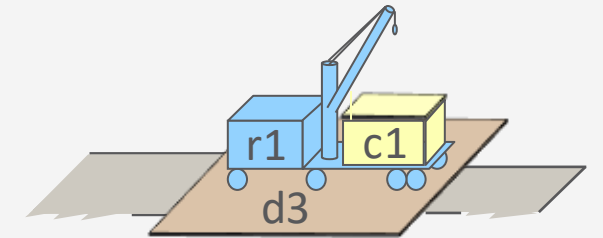

$g = \{loc(r1) = d3, loc(c1) = r1\}$

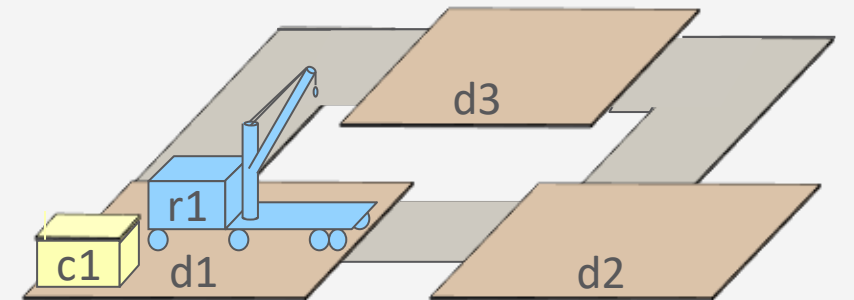

$s_1 = \{loc(r1) = d1, cargo(r1) = nil, loc(c1) = d1\}$

# Example

```

// construct a relaxed solution  $\langle A_1, A_2, \dots, A_k \rangle$ :
 $\hat{s}_0 \leftarrow s$ 
for  $k = 1; k++$ ; subset of  $\hat{s}_k$  r-satisfies  $g$  do
   $A_k = \{\text{all actions r-applicable in } \hat{s}_{k-1}\}$ 
   $\hat{s}_k = \gamma^+(s_{k-1}, A_k)$ 
  if  $k > 1$  and  $\hat{s}_k = \hat{s}_{k-1}$  then
    return  $\infty$  // there's no solution
  
```

Deterministic

## RPG from $\hat{s}_0 = s_2$ to $g$

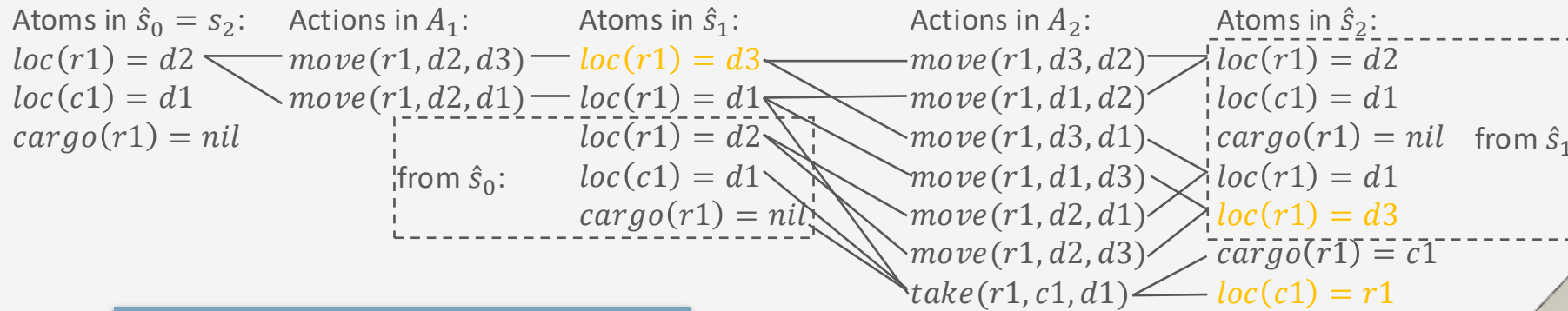

$\langle A_1, A_2 \rangle$  is a relaxed solution

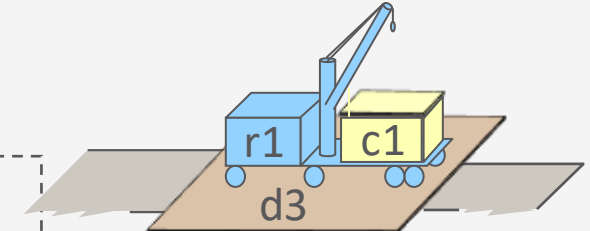

$g = \{loc(r1) = d3, loc(c1) = r1\}$

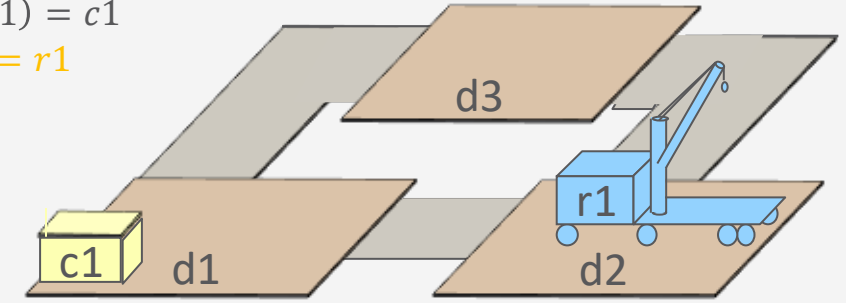

$s_2 = \{loc(r1) = d2, cargo(r1) = nil, loc(c1) = d1\}$

# Example

```
// extract minimal relaxed solution
```

```
 $\hat{g}_k = g$ 
```

```
for  $i = k$  down to 1 do
```

```
   $\hat{a}_i =$  minimal subset of  $A_i$  s.t.  $\gamma^+(\hat{s}_{i-1}, \hat{a}_i)$  r-satisfies  $\hat{g}_i$ 
```

```
   $\hat{g}_{i-1} \leftarrow (\hat{g}_i \setminus \text{eff}(\hat{a}_i)) \cup \text{pre}(\hat{a}_i)$ 
```

Deterministic

Could have followed other eff. line

RPG from  $\hat{s}_0 = s_2$  to  $g$

Atoms in  $\hat{s}_0 = s_2$ :

- $loc(r1) = d2$
- $loc(c1) = d1$
- $cargo(r1) = nil$

Actions in  $A_1$ :

- $move(r1, d2, d3)$
- $move(r1, d2, d1)$

$\langle \hat{a}_1 \rangle$

from  $\hat{s}_0$ :

Atoms in  $\hat{s}_1$ :

- $loc(r1) = d3$
- $loc(r1) = d1$
- $loc(r1) = d2$
- $loc(c1) = d1$
- $cargo(r1) = nil$

Actions in  $A_2$ :

- $move(r1, d3, d2)$
- $move(r1, d1, d2)$
- $move(r1, d3, d1)$
- $move(r1, d1, d3)$
- $move(r1, d2, d1)$
- $move(r1, d2, d3)$
- $take(r1, c1, d1)$

$\langle \hat{a}_2 \rangle$

Atoms in  $\hat{s}_2$ :

- $loc(r1) = d2$
- $loc(c1) = d1$
- $cargo(r1) = nil$
- $loc(r1) = d1$
- $loc(r1) = d3$
- $cargo(r1) = c1$
- $loc(c1) = r1$

from  $\hat{s}_1$

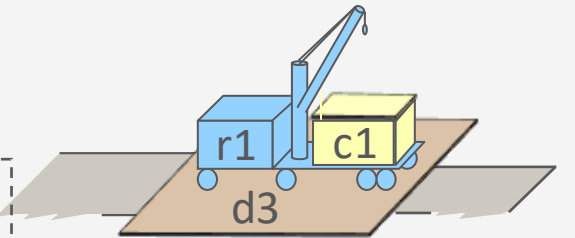

$g = \{loc(r1) = d3, loc(c1) = r1\}$

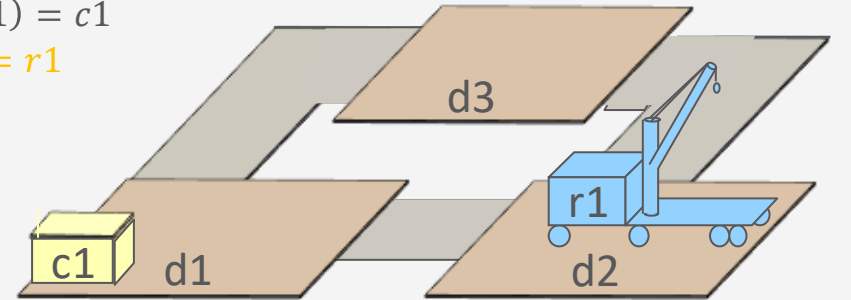

$s_2 = \{loc(r1) = d2, cargo(r1) = nil, loc(c1) = d1\}$

- $\langle \hat{a}_1, \hat{a}_2 \rangle$  is a minimal relaxed solution
- Cost of each action is 1, so  $h^{FF}(s_2) = 3$

## Properties

- Running time is polynomial in  $|A| + \sum_{x \in X} |\text{ran}(x)|$
- *Minimal solution* does not mean *smallest cost*
  - A solution  $\pi$  to  $P$  is **minimal** if
    - no subsequence of  $\pi$  is also a solution for  $P$ .
  - A solution  $\pi$  to  $P$  is **shortest** if
    - there is no solution  $\pi'$  such that  $|\pi'| < |\pi|$ .
  - A solution  $\pi$  to  $P$  is **cost-optimal** if
    - $\text{cost}(\pi) = \min\{\text{cost}(\pi') \mid \pi' \text{ is a solution for } P\}$ .
  - $h^{FF}(s)$  = value returned by  $\text{HFF}(\Sigma, s, g)$ 
    - $h^{FF}(s) = \Sigma$  costs of  $\hat{a}_1, \dots, \hat{a}_k$
  - $h^{FF}(s) \geq h^+(s)$  = *smallest* cost of any relaxed plan from  $s$  to goal
  - $h^{FF}$  **not** admissible

## Example

- Suppose the goal atoms are c7, c8, c9. How many minimal solutions are there?
  - Assume default cost of 1

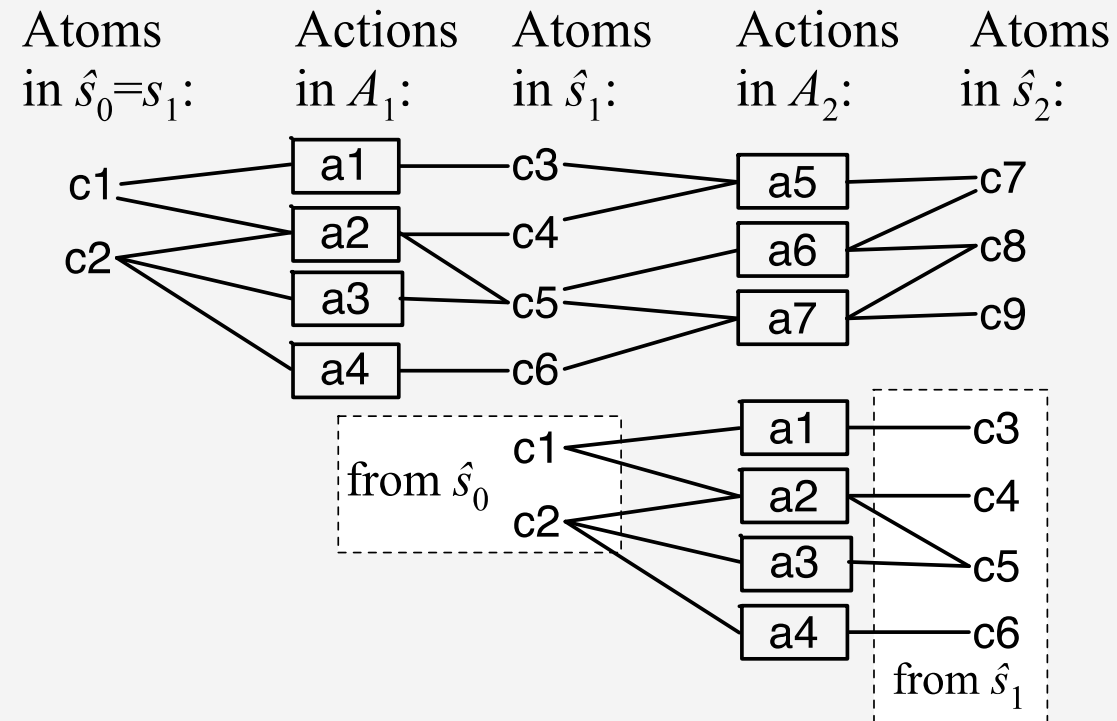

## Landmark Heuristics

- $P = (\Sigma, s_0, g)$  be a planning problem
- Let  $\varphi = \varphi_1 \vee \dots \vee \varphi_m$  be a disjunction of ground atoms
- $\varphi$  is a **landmark** for  $P$  if  $\varphi$  is true at some point in every solution for  $P$
- Example landmarks
  - $loc(r1) = d1$
  - $loc(r1) = d3 \vee loc(r1) = d2$
  - $loc(r1) = d3$

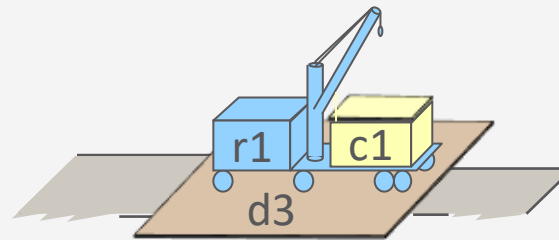

$g = \{loc(r1) = d3, loc(c1) = r1\}$

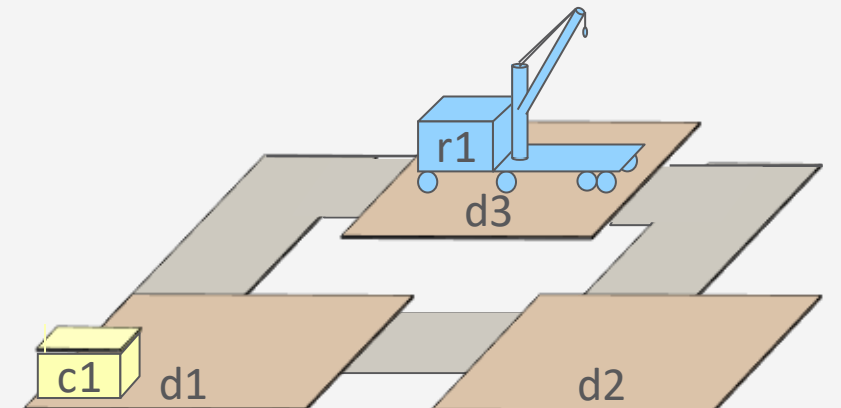

$s_0 = \{loc(r1) = d3, cargo(r1) = nil, loc(c1) = d1\}$

## Why are Landmarks Useful?

- Breaks down a problem into smaller subproblems

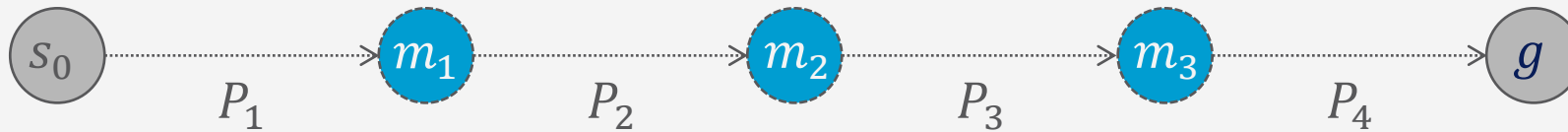

- Suppose  $m_1, m_2, m_3$  are landmarks
  - Every solution to  $P$  must achieve  $m_1, m_2, m_3$
- Possible strategy:
  - Find a plan to go from  $s_0$  to any state  $s_1$  that satisfies  $m_1$
  - Find a plan to go from  $s_1$  to any state  $s_2$  that satisfies  $m_2$
  - ...

## Computing Landmarks

- Worst-case complexity:
  - Deciding whether  $\varphi$  is a landmark is PSPACE-complete
  - As hard as solving the planning problem itself
- But there are often useful landmarks that can be found more easily
  - Polynomial time
  - Going to see one such procedure based on *RPGs*
    - Why RPGs?
      - Solving relaxed planning problems easier
      - Computing landmarks for relaxed planning problems easier
      - A landmark for a relaxed planning problem is a landmark for the original planning problem as well

## RPG-based Landmark Computation

- Main intuition: If  $\varphi$  is a landmark, can get new landmarks from the preconditions of the actions that achieve  $\varphi$
- Example:
  - Goal  $g$
  - $\{a_1, a_2\}$  = all actions that achieve  $g$
  - $pre(a_1) = \{p_1, q\}$
  - $pre(a_2) = \{q, p_2\}$
  - To achieve  $g$ , must achieve  $(q \wedge p_1) \vee (q \wedge p_2)$ 
    - Same as  $q \wedge (p_1 \vee p_2)$
  - Landmarks:
    - $q$
    - $p_1 \vee p_2$

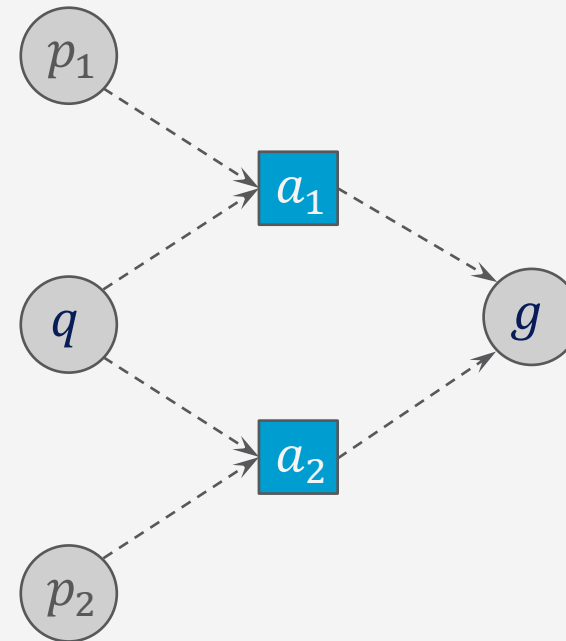

## RPG-based Landmark Computation

- Suppose goal is  $g = \{g_1, g_2, \dots, g_k\}$ 
  - Trivially, every  $g_i$  is a landmark
- Suppose  $g_1 = (loc(r1) = d1)$ 
  - Two actions can achieve  $g_1$ :
    - $move(r1, d3, d1)$
    - $move(r1, d2, d1)$
  - Preconditions
    - $loc(r1) = d3$
    - $loc(r1) = d2$
- New landmark:  $\varphi' = (loc(r1) = d3 \vee loc(r1) = d2)$

- $move(r, l, m)$ 
  - pre:  $loc(r) = l$
  - eff:  $loc(r) \leftarrow m$

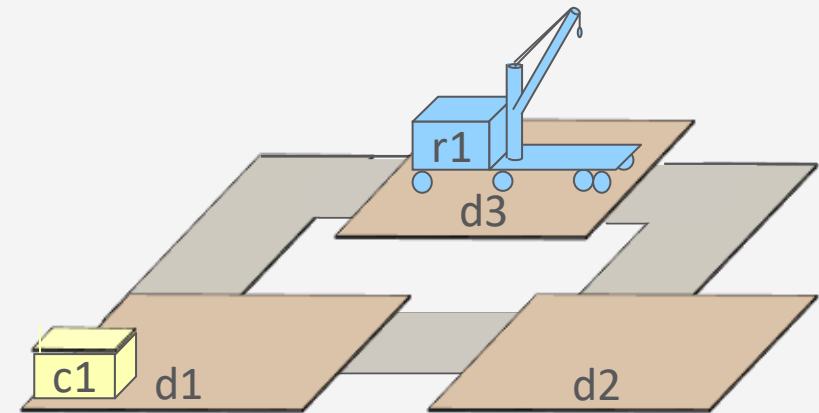

$s_0 = \{loc(r1) = d3, cargo(r1) = nil, loc(c1) = d1\}$

# RPG-based Landmark Computation

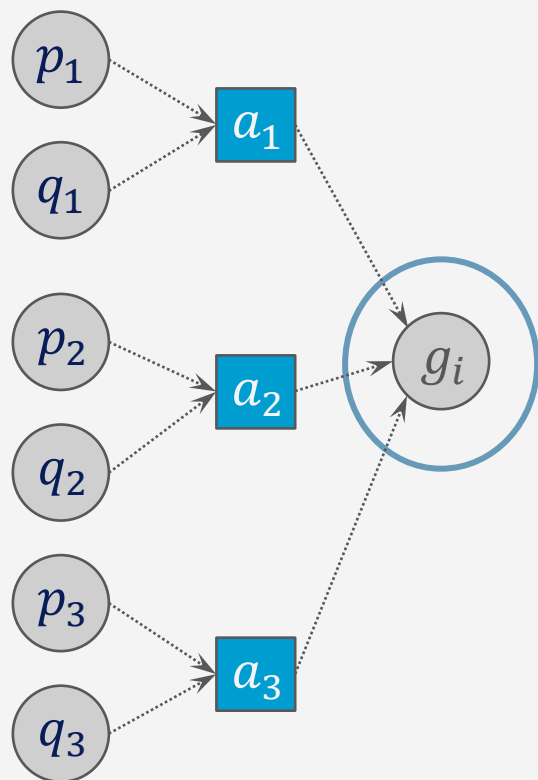

Inputs:

- Planning domain  $\Sigma$
- Initial state  $s_0$
- Set of goal atoms  $g$

**RPG-Landmarks** ( $\Sigma, s_0, g = \{g_1, g_2, \dots, g_k\}$ )

$queue \leftarrow \{g_i \in g \mid s_0 \text{ does not satisfy } g_i\};$

$Landmarks \leftarrow \emptyset$

$A \leftarrow$  all actions

**while**  $queue \neq \emptyset$  **do**

remove a  $g_i$  from  $queue$

$Landmarks \leftarrow Landmarks \cup g_i$

$R \leftarrow$  {actions whose effects include  $g_i$ }

**if**  $s_0$  satisfies  $pre(a)$  for some  $a \in R$  **then**

**return**  $Landmarks$

generate RPG from  $s_0$  and  $A \setminus R$ , stop when  $\hat{s}_k = \hat{s}_{k-1}$

$N \leftarrow \{a \in R \mid a \text{ r-applicable in } \hat{s}_k\}$

**if**  $N = \emptyset$  **then**

**return** failure

$Pre \leftarrow \cup \{pre(a) \mid a \in N\} \setminus s_0$

$\Phi \leftarrow \{p_1 \vee p_2 \vee \dots \vee p_m \mid m \leq 4, \forall a \in N \exists i : p_i \in pre(a), \forall i : p_i \in Pre\}$

**for** each  $\varphi \in \Phi$  **do**

add  $\varphi$  to  $queue$

**return**  $Landmarks$

# RPG-based Landmark Computation

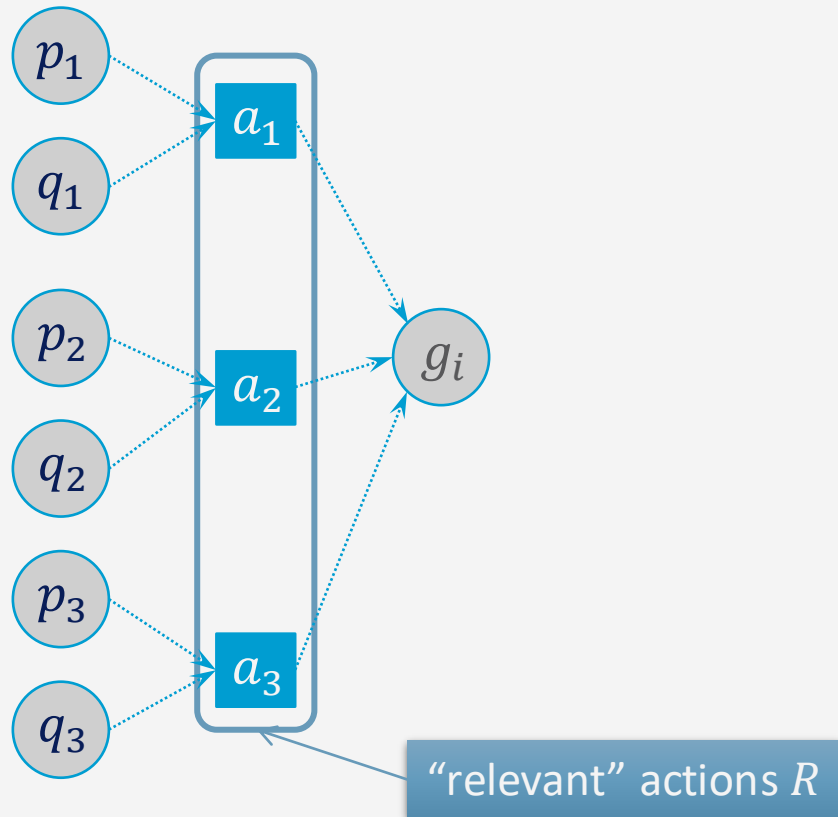

```

RPG-Landmarks( $s_0, g = \{g_1, g_2, \dots, g_k\}$ )
  queue  $\leftarrow \{g_i \in g \mid s_0 \text{ doesn't satisfy } g_i\};$ 
  Landmarks  $\leftarrow \emptyset$ 
  A  $\leftarrow$  all actions
  while queue  $\neq \emptyset$  do
    remove a  $g_i$  from queue
    Landmarks  $\leftarrow$  Landmarks  $\cup g_i$ 
    R  $\leftarrow$  {actions whose effects include  $g_i$ }
    if  $s_0$  satisfies  $\text{pre}(a)$  for some  $a \in R$  then
      return Landmarks
    generate RPG from  $s_0$  and  $A \setminus R$ , stop when  $\hat{s}_k = \hat{s}_{k-1}$ 
    N  $\leftarrow \{a \in R \mid a \text{ r-applicable in } \hat{s}_k\}$ 
    if N =  $\emptyset$  then
      return failure
    Pre  $\leftarrow \cup \{\text{pre}(a) \mid a \in N\} \setminus s_0$ 
     $\Phi \leftarrow \{p_1 \vee p_2 \vee \dots \vee p_m \mid m \leq 4, \forall a \in N \exists i: p_i \in \text{pre}(a), \forall i: p_i \in \text{Pre}\}$ 
    for each  $\varphi \in \Phi$  do
      add  $\varphi$  to queue
  return Landmarks
  
```

# RPG-based Landmark Computation

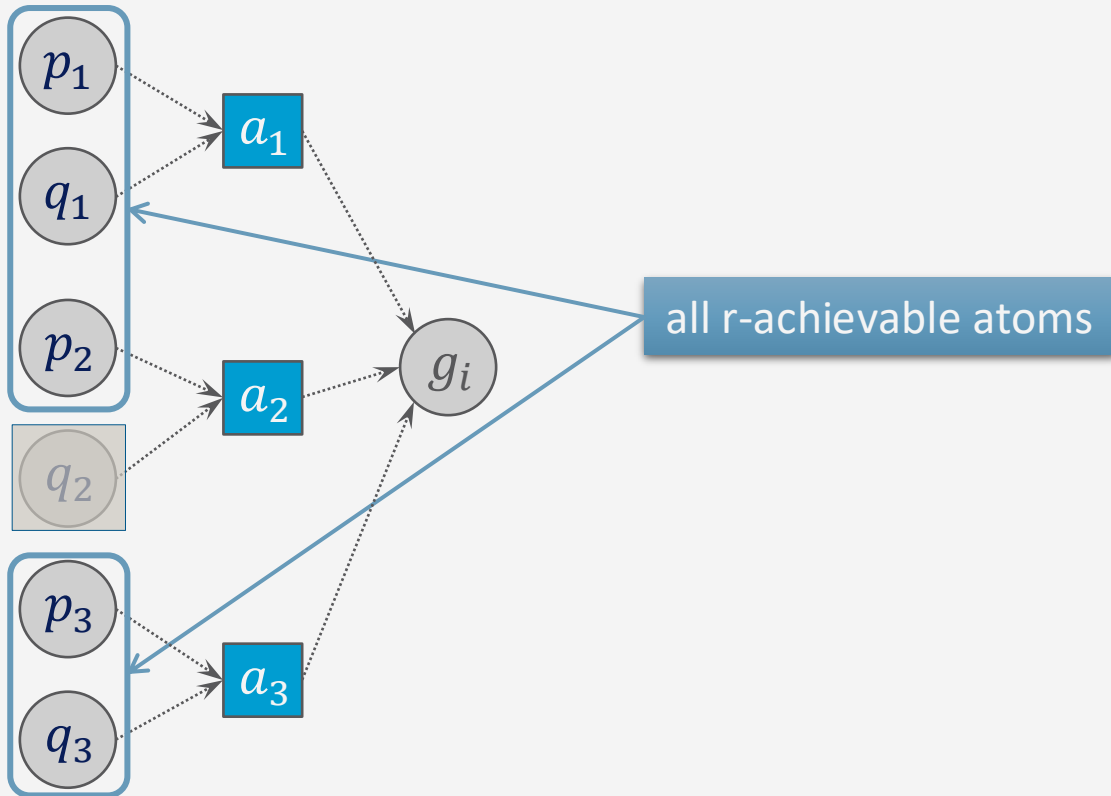

```
RPG-Landmarks( $s_0, g = \{g_1, g_2, \dots, g_k\}$ )
```

```
queue  $\leftarrow \{g_i \in g \mid s_0 \text{ doesn't satisfy } g_i\};$ 
```

```
Landmarks  $\leftarrow \emptyset$ 
```

```
A  $\leftarrow$  all actions
```

```
while queue  $\neq \emptyset$  do
```

```
  remove a  $g_i$  from queue
```

```
  Landmarks  $\leftarrow$  Landmarks  $\cup g_i$ 
```

```
  R  $\leftarrow$  {actions whose effects include  $g_i$ }
```

```
  if  $s_0$  satisfies  $\text{pre}(a)$  for some  $a \in R$  then
```

```
    return Landmarks
```

```
  generate RPG from  $s_0$  and  $A \setminus R$ , stop when  $\hat{s}_k = \hat{s}_{k-1}$ 
```

```
  N  $\leftarrow$  { $a \in R \mid a$  r-applicable in  $\hat{s}_k$ }
```

```
  if N =  $\emptyset$  then
```

```
    return failure
```

```
  Pre  $\leftarrow \cup \{\text{pre}(a) \mid a \in N\} \setminus s_0$ 
```

```
   $\Phi \leftarrow \{p_1 \vee p_2 \vee \dots \vee p_m \mid m \leq 4, \forall a \in N \exists i: p_i \in \text{pre}(a), \forall i: p_i \in \text{Pre}\}$ 
```

```
  for each  $\varphi \in \Phi$  do
```

```
    add  $\varphi$  to queue
```

```
return Landmarks
```

# RPG-based Landmark Computation

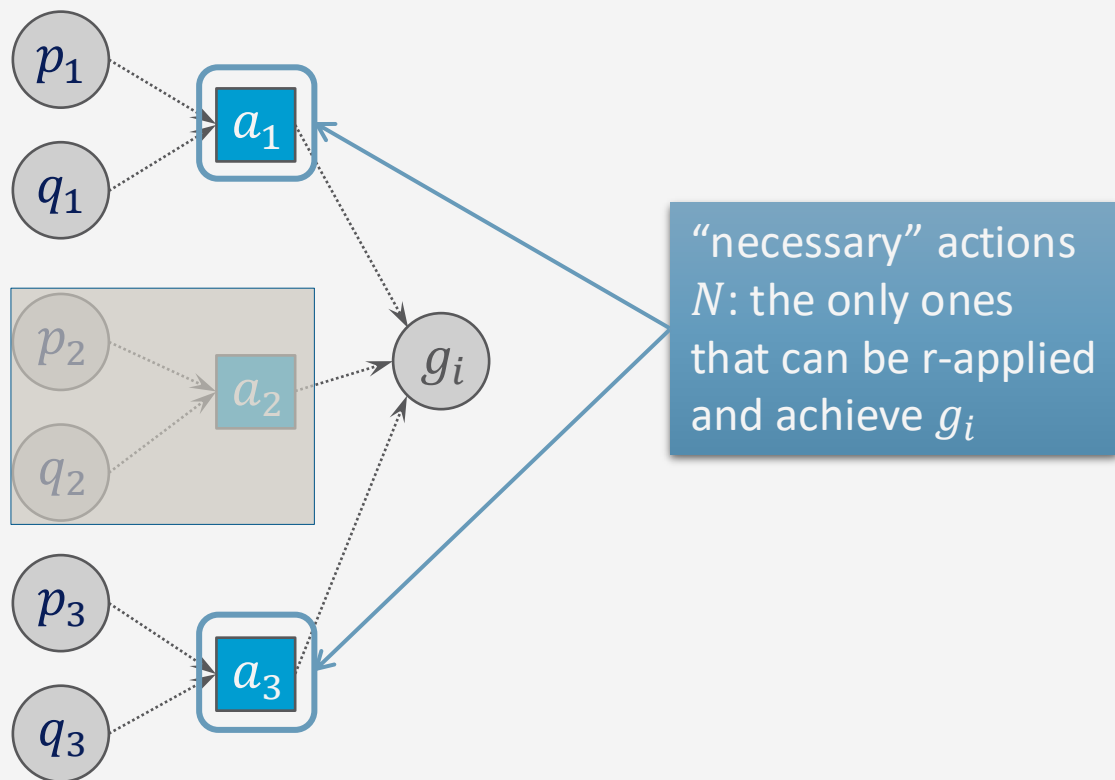

```

RPG-Landmarks ( $s_0, g = \{g_1, g_2, \dots, g_k\}$ )
  queue  $\leftarrow \{g_i \in g \mid s_0 \text{ doesn't satisfy } g_i\}$ ;
  Landmarks  $\leftarrow \emptyset$ 
  A  $\leftarrow$  all actions
  while queue  $\neq \emptyset$  do
    remove a  $g_i$  from queue
    Landmarks  $\leftarrow$  Landmarks  $\cup g_i$ 
    R  $\leftarrow$  {actions whose effects include  $g_i$ }
    if  $s_0$  satisfies  $pre(a)$  for some  $a \in R$  then
      return Landmarks
    generate RPG from  $s_0$  and  $A \setminus R$ , stop when  $\hat{s}_k = \hat{s}_{k-1}$ 
    N  $\leftarrow \{a \in R \mid a \text{ r-applicable in } \hat{s}_k\}$ 
    if  $N = \emptyset$  then
      return failure
    Pre  $\leftarrow \cup \{pre(a) \mid a \in N\} \setminus s_0$ 
     $\Phi \leftarrow \{p_1 \vee p_2 \vee \dots \vee p_m \mid m \leq 4, \forall a \in N \exists i: p_i \in pre(a), \forall i: p_i \in Pre\}$ 
    for each  $\varphi \in \Phi$  do
      add  $\varphi$  to queue
  return Landmarks
  
```

# RPG-based Landmark Computation

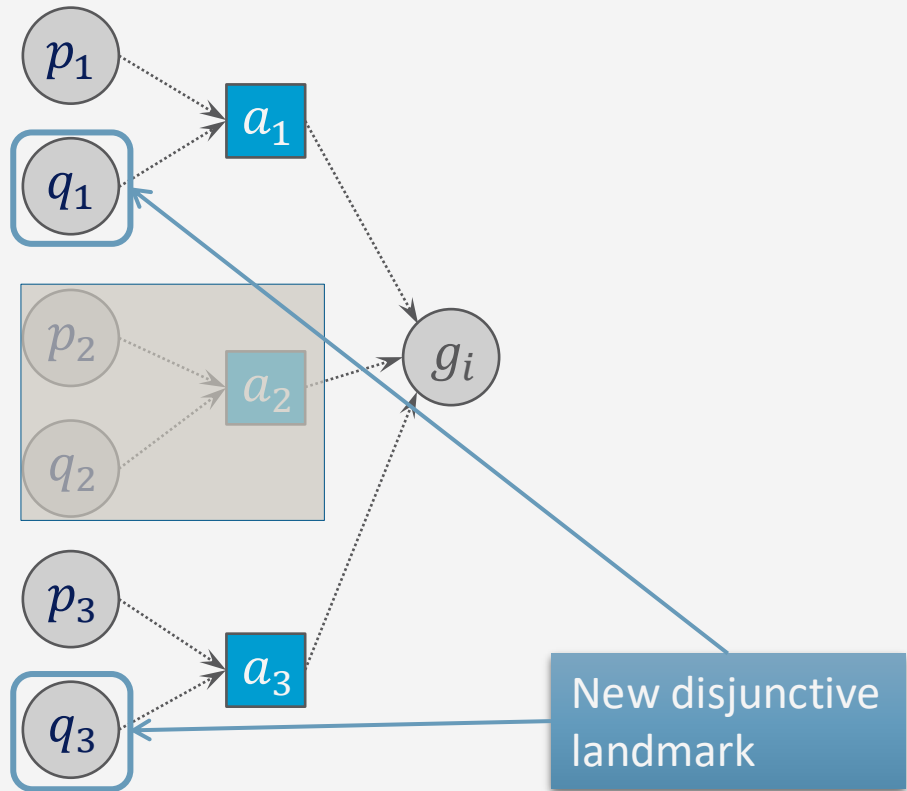

```

RPG-Landmarks ( $s_0, g = \{g_1, g_2, \dots, g_k\}$ )
  queue  $\leftarrow \{g_i \in g \mid s_0 \text{ doesn't satisfy } g_i\}$ ;
  Landmarks  $\leftarrow \emptyset$ 
  A  $\leftarrow$  all actions
  while queue  $\neq \emptyset$  do
    remove a  $g_i$  from queue
    Landmarks  $\leftarrow$  Landmarks  $\cup g_i$ 
    R  $\leftarrow$  {actions whose effects include  $g_i$ }
    if  $s_0$  satisfies pre(a) for some  $a \in R$  then
      return Landmarks
    generate RPG from  $s_0$  and  $A \setminus R$ , stop when  $\hat{s}_k = \hat{s}_{k-1}$ 
    N  $\leftarrow$  { $a \in R \mid a$  r-applicable in  $\hat{s}_k$ }
    if N =  $\emptyset$  then
      return failure
    Pre  $\leftarrow \cup \{\text{pre}(a) \mid a \in N\} \setminus s_0$ 
     $\Phi \leftarrow \{p_1 \vee p_2 \vee \dots \vee p_m \mid m \leq 4, \forall a \in N \exists i: p_i \in \text{pre}(a), \forall i: p_i \in \text{Pre}\}$ 
    for each  $\varphi \in \Phi$  do
      add  $\varphi$  to queue
  return Landmarks
  
```

# Example

```

queue = {loc(c1) = r1}
Landmarks = ∅
  
```

```

RPG-Landmarks (s0, g = {g1, g2, ..., gk})
queue ← {gi ∈ g | s0 doesn't satisfy gi};
Landmarks ← ∅
A ← all actions
while queue ≠ ∅ do
  ...
  
```

- *move*(*r*, *l*, *m*)
  - pre: *loc*(*r*) = *l*
  - eff: *loc*(*r*) ← *m*
- *take*(*r*, *l*, *c*)
  - pre: *cargo*(*r*) = *nil*, *loc*(*r*) = *l*, *loc*(*c*) = *l*
  - eff: *cargo*(*r*) ← *c*, *loc*(*c*) ← *r*
- *put*(*r*, *l*, *c*)
  - pre: *loc*(*r*) = *l*, *loc*(*c*) = *r*
  - eff: *cargo*(*r*) ← *nil*, *loc*(*c*) ← *l*

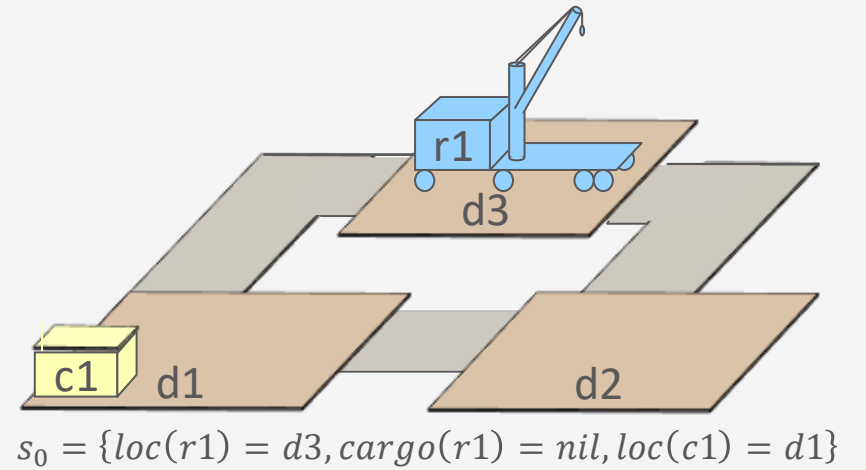
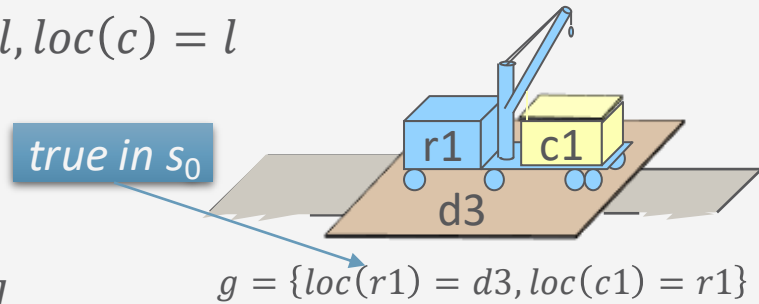

# Example

```

queue = ∅
Landmarks = {loc(c1) = r1}
R = {take(r1, d1, c1), take(r1, d2, c1), take(r1, d3, c1)}
  
```

```

RPG-Landmarks( $s_0, g = \{g_1, g_2, \dots, g_k\}$ )
...
while queue ≠ ∅ do
  remove a  $g_i$  from queue
  Landmarks ← Landmarks ∪  $g_i$ 
  R ← {actions whose effects include  $g_i$ }
  if  $s_0$  satisfies pre( $a$ ) for some  $a \in R$  then
    return Landmarks
  
```

- $move(r, l, m)$ 
  - pre:  $loc(r) = l$
  - eff:  $loc(r) \leftarrow m$
- $take(r, l, c)$ 
  - pre:  $cargo(r) = nil, loc(r) = l, loc(c) = l$
  - eff:  $cargo(r) \leftarrow c, loc(c) \leftarrow r$
- $put(r, l, c)$ 
  - pre:  $loc(r) = l, loc(c) = r$
  - eff:  $cargo(r) \leftarrow nil, loc(c) \leftarrow l$

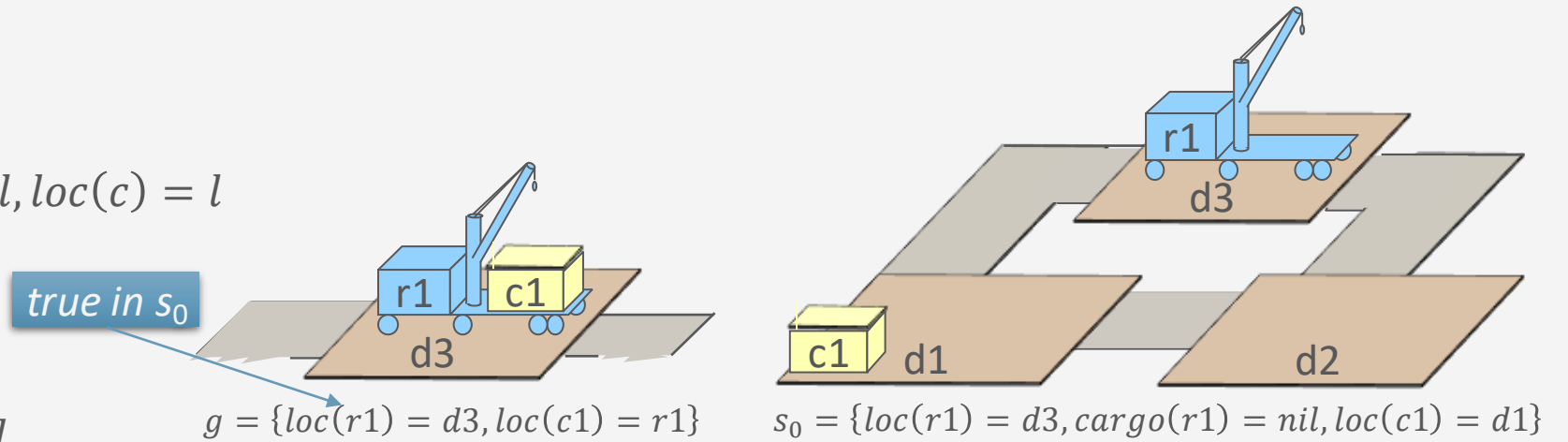

# Example

```
queue = ∅
Landmarks = {loc(c1) = r1}
R = {take(r1, d1, c1), take(r1, d2, c1), take(r1, d3, c1)}
```

- *move*(*r*, *l*, *m*)
  - pre: *loc*(*r*) = *l*
  - eff: *loc*(*r*) ← *m*
- *take*(*r*, *l*, *c*)
  - pre: *cargo*(*r*) = *nil*, *loc*(*r*) = *l*, *loc*(*c*) = *l*
  - eff: *cargo*(*r*) ← *c*, *loc*(*c*) ← *r*
- *put*(*r*, *l*, *c*)
  - pre: *loc*(*r*) = *l*, *loc*(*c*) = *r*
  - eff: *cargo*(*r*) ← *nil*, *loc*(*c*) ← *l*

```
RPG-Landmarks(s0, g = {g1, g2, ..., gk})
...
while queue ≠ ∅ do
...
  generate RPG from s0 and A \ R, stop when ŝk = ŝk-1
  N ← {a ∈ R | a r-applicable in ŝk}
  if N = ∅ then
    return failure
```

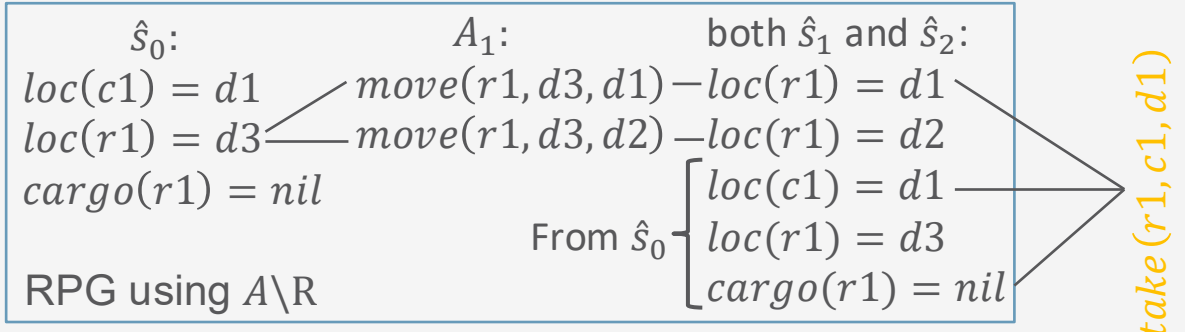

## Example

```

queue = ∅
Landmarks = {loc(c1) = r1}
R = {take(r1, d1, c1), take(r1, d2, c1), take(r1, d3, c1)}
N = {take(r1, d1, c1)}

```

- *move*(*r*, *l*, *m*)
  - pre: *loc*(*r*) = *l*
  - eff: *loc*(*r*) ← *m*
- *take*(*r*, *l*, *c*)
  - pre: *cargo*(*r*) = *nil*, *loc*(*r*) = *l*, *loc*(*c*) = *l*
  - eff: *cargo*(*r*) ← *c*, *loc*(*c*) ← *r*
- *put*(*r*, *l*, *c*)
  - pre: *loc*(*r*) = *l*, *loc*(*c*) = *r*
  - eff: *cargo*(*r*) ← *nil*, *loc*(*c*) ← *l*

```
RPG-Landmarks(s0, g = {g1, g2, ..., gk})
```

```

...
while queue ≠ ∅ do

```

```

...
Pre ← ∪{pre(a) | a ∈ N} \ s0
Φ ← {p1∨p2∨...∨pm | m ≤ 4, ∀a ∈ N ∃i: pi ∈ pre(a), ∀i: pi ∈ Pre}
for each φ ∈ Φ do
  add φ to queue

```

```

take(r1, d1, c1)
pre: cargo(r1) = nil, ← satisfied in  $\hat{S}_0$ 
    loc(c1) = d1, ←
    loc(r1) = d1 ← add to queue

```

## Landmark Heuristics

- Every solution to the problem needs to achieve all the computed landmarks
- One possible heuristics:
  - $h^{sl}(s)$  = number of landmarks returned by RPG-Landmarks
  - Is this heuristics admissible?
    - No

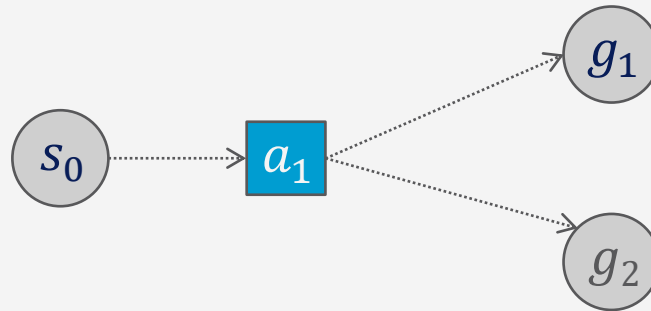

$g = \{g_1, g_2\}$   
Two landmarks:  $g_1, g_2$   
Optimal plan:  $\langle a_1 \rangle$ , length = 1

- There are other more-advanced landmark heuristics
  - Some of them are admissible
  - Check textbook for references

## Intermediate Summary

- Heuristic functions
  - Straight-line distance example
  - Delete-relaxation heuristics
    - Relaxed states,  $\gamma^+$ ,  $h^+$ , HFF,  $h^{FF}$
  - Disjunctive landmarks, RPG-Landmark,  $h^{sl}$ 
    - Get necessary actions by making RPG for all non-relevant actions

## Outline per the Book

### 2.1 *State-variable representation*

- State = {values of variables}; action = changes to those values

### 2.2 *Forward state-space search*

- Start at initial state, look for sequence of actions that achieve goal

### 2.3 *Heuristic functions*

- How to guide a forward state-space search

### 2.6 *Incorporating planning into an actor*

- Online lookahead, unexpected events

### 2.4 *Backward search*

- Start at goal state, go backwards toward initial state

### 2.5 *Plan-space search*

- Start with incomplete plan for getting from initial state to goal state, make transformations to fix flaws in the plan

## Incorporating Planning into an Actor

- Plans are abstract
  - Need additional refinement
  - (Chapter 3 / next lecture)

*The best laid schemes o' mice an' men,  
Gang aft a'gley.*

—Robert Burns

- Plans do not always work
  - What to do about it?

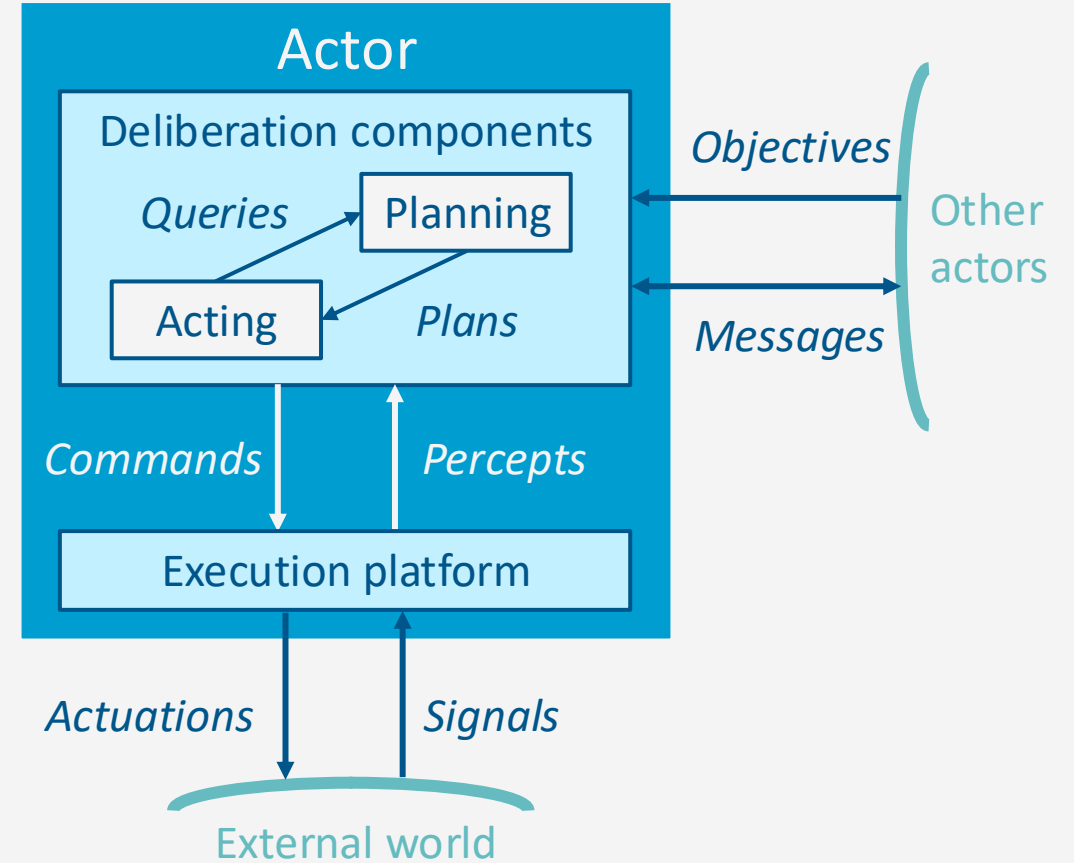

# Service Robot

- $s_0 = \{loc(r1) = loc3, loc(o7) = loc1, cargo(r1) = nil\}$
- $g = \{loc(o7) = loc2\}$
- $\pi = \langle a1, a2, a3, a4, a5 \rangle$ 
  - $a1 = go(r1, loc3, hall)$
  - $a2 = navigate(r1, hall, loc1)$
  - $a3 = take(r1, loc1, o7)$
  - $a4 = navigate(r1, loc1, loc2)$
  - $a5 = put(r1, loc2, o7)$

What are possible issues?

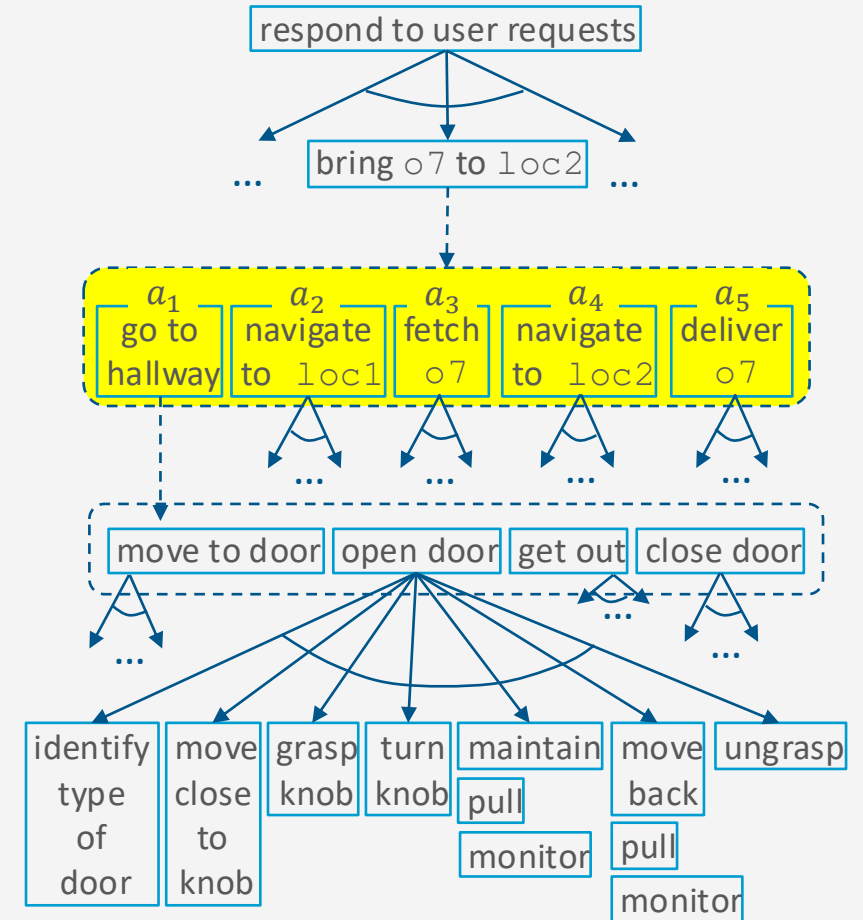

# Using Planning in Acting

- LOOKAHEAD is the planner
- Receding **horizon**:
  - Call LOOKAHEAD, obtain  $\pi$ , perform 1<sup>st</sup> action, call LOOKAHEAD again ...
  - Like game-tree search (chess, checkers, etc.)
- Useful when unpredictable things are likely to happen
  - Re-plans immediately
- Potential problem:
  - May pause repeatedly while waiting for LOOKAHEAD to return
  - What if  $\xi$  changes during the wait?

```
Run-Lookahead( $\Sigma, g$ )
```

```
while  $s \leftarrow$  abstraction of observed state  $\xi \neq g$  do  
   $\pi \leftarrow$  Lookahead( $\Sigma, s, g$ )  
  if  $\pi =$  failure then  
    return failure  
   $a \leftarrow$  pop-first-action( $\pi$ )  
  perform  $a$ 
```

Inputs:

- Planning domain  $\Sigma$
- Goal description  $g$

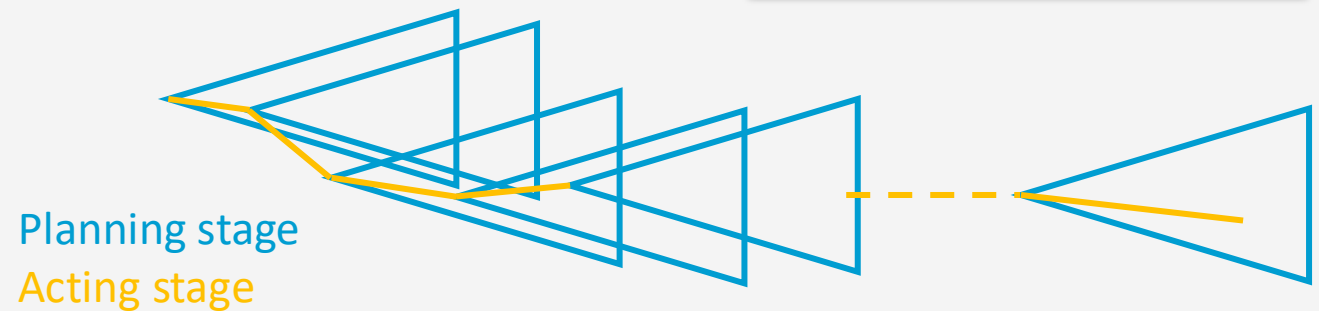

## Using Planning in Acting

- Call LOOKAHEAD, execute the plan as far as possible, do not call LOOKAHEAD again unless necessary
- SIMULATE tests if the plan will execute correctly
  - Could just compute  $\gamma(s, \pi)$ , or could do something more detailed
    - Lower-level refinement, physics-based simulation
- Potential problems
  - May miss opportunities to replace  $\pi$  with a better plan
  - Without SIMULATE, may not detect problems until it is too late

### Run-Lazy-Lookahead ( $\Sigma, g$ )

```

s ← abstraction of observed state  $\xi$ 
while s  $\neq$  g do
   $\pi$  ← Lookahead( $\Sigma, s, g$ )
  if  $\pi$  = failure then
    return failure
  while  $\pi \neq \langle \rangle$  and s  $\neq$  g and
    Simulate( $\Sigma, s, g, \pi$ )  $\neq$  failure do
    a ← pop-first-action( $\pi$ )
    perform a
  s ← abstraction of observed state  $\xi$ 

```

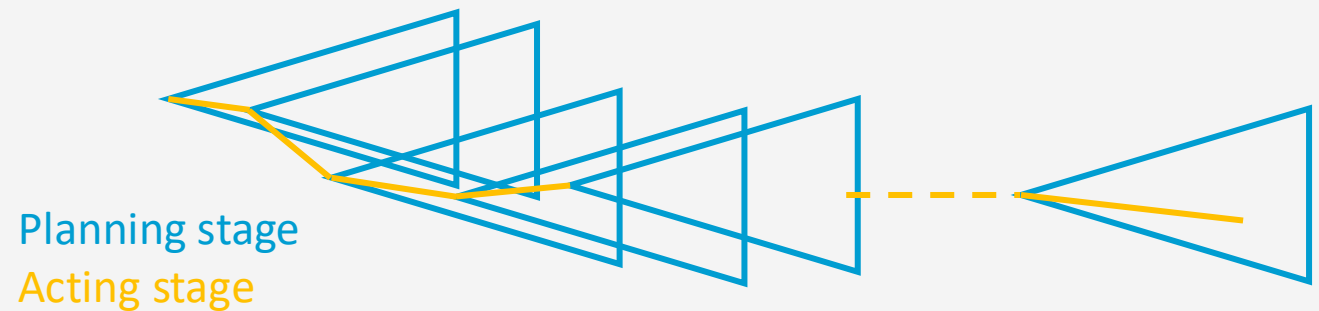

## Using Planning in Acting

- May detect opportunities earlier than Run-Lazy-Lookahead
  - But may miss some that Run-Lookahead would find
- Without SIMULATE, may fail to detect problems until it is too late
  - Not as bad at this as Run-Lazy-Lookahead
  - Possible work-around: restart LOOKAHEAD each time  $s$  changes

```
Run-Concurrent-Lookahead ( $\Sigma, g$ )  
   $\pi \leftarrow \langle \rangle$   
   $s \leftarrow$  abstraction of observed state  $\xi$   
  // thread 1 + 2 run concurrently  
thread 1:  
  loop  
     $\pi \leftarrow$  Lookahead( $\Sigma, s, g$ )  
thread 2:  
  loop  
    if  $s \models g$  then  
      return success  
    else if  $\pi =$  failure then  
      return failure  
    else if  $\pi \neq \langle \rangle$  and  $s \not\models g$  and  
      Simulate( $\Sigma, s, g, \pi$ )  $\neq$  failure then  
       $a \leftarrow$  pop-first-action( $\pi$ )  
      perform  $a$   
       $s \leftarrow$  abstraction of observed state  $\xi$ 
```

## How to do Lookahead

- **Subgoaling**: Instead of planning for  $g$ , plan for a subgoal  $g'$ 
  - Once  $g'$  is achieved, plan for next subgoal
  - E.g., using landmarks
- **Receding horizon**: Return a plan that goes just part-way to  $g'$ 
  - E.g., cut off search when
    - Plan's cost exceeds some value  $c_{max}$
    - Plan's length exceeds some value  $l_{max}$
    - No time left
  - Horizon recedes on the actor's successive calls to the planner
- **Sampling**: Try a few (e.g., randomly chosen) depth-first rollouts, take the one that looks best
- Can use combinations of these

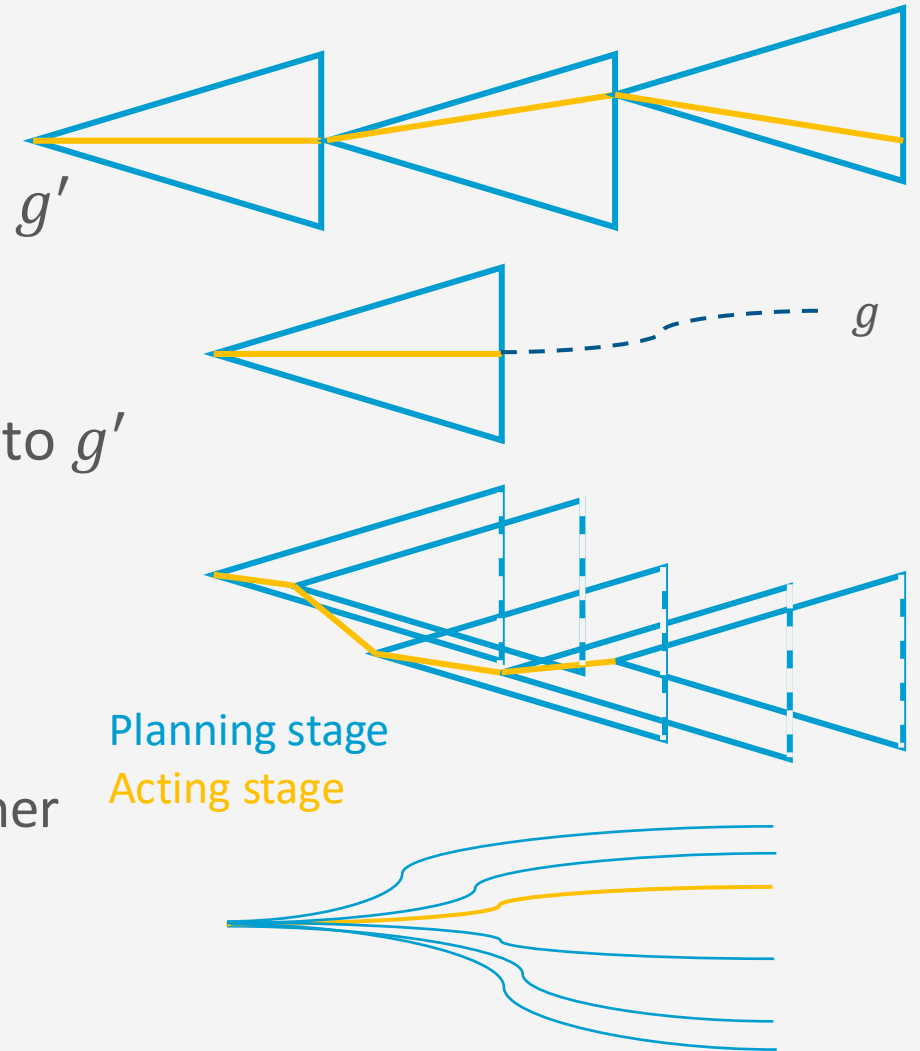

## Receding-Horizon Search

- After line (i), put something like these:
  - Cost-based cutoff:  
**if**  $cost(\pi) + h(s) > c_{max}$  **then**  
    **return**  $\pi$
  - Length-based cutoff:  
**if**  $|\pi| > l_{max}$  **then**  
    **return**  $\pi$
  - Time-based cutoff:  
**if**  $time-left() = 0$  **then**  
    **return**  $\pi$

### Deterministic-Search ( $\Sigma, s_0, g$ )

```
Frontier  $\leftarrow$  { ( $\langle \rangle, s_0$ ) }
```

```
Expanded  $\leftarrow$   $\emptyset$ 
```

```
while Frontier  $\neq$   $\emptyset$  do
```

```
    select a node  $v = (\pi, s) \in$  Frontier (i)
```

```
    remove  $v$  from Frontier
```

```
    add  $v$  to Expanded
```

```
    if  $s$  satisfies  $g$  then
```

```
        return  $\pi$ 
```

```
    Children  $\leftarrow$ 
```

```
        {  $(\pi.a, \gamma(s, a)) \mid s$  satisfies  $pre(a)$  }
```

```
    prune 0 or more nodes from
```

```
        Children, Frontier, Expanded (ii)
```

```
    Frontier  $\leftarrow$  Frontier  $\cup$  Children
```

```
return failure
```

Input:

- Planning problem ( $\Sigma, s_0, g$ )

## Partial or Non-optimal Plans

- Sampling
  - Planner is a modified version of greedy algorithm
  - Make randomized choice at (i)
  - Run several times, get several solutions
  - Return best one
- Actor calls the planner repeatedly as it acts
  - An analogous technique is used in the game of Go

```
Greedy( $\Sigma, s_0, g, Visited$ )  
  if  $s$  satisfies  $g$  then  
    return  $\pi$   
   $Act \leftarrow \{a \in A \mid s \text{ satisfies } pre(a) \text{ and } \gamma(s, a) \notin Visited\}$   
  if  $Act = \emptyset$  then  
    return failure  
   $a \leftarrow \operatorname{argmin}_{a \in Act} h(\gamma(s, a))$  (i)  
   $\pi \leftarrow \text{Greedy}(\Sigma, \gamma(s, a), g, Visited \cup \{s\})$   
  if  $\pi \neq failure$  then  
    return  $a.\pi$   
  return failure
```

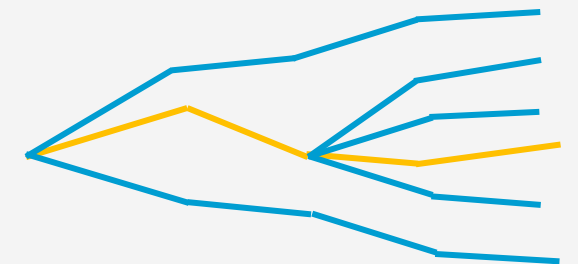

Planning stage  
Acting stage

## Intermediate Summary

- Incorporating Planning into an actor
  - Things that can go wrong while acting
  - Algorithms
    - Run-Lookahead
    - Run-Lazy-Lookahead
    - Run-Concurrent-Lookahead
  - Lookahead
    - Subgoalting
    - Receding-horizon search
    - Sampling

## Outline per the Book

### 2.1 *State-variable representation*

- State = {values of variables}; action = changes to those values

### 2.2 *Forward state-space search*

- Start at initial state, look for sequence of actions that achieve goal

### 2.3 *Heuristic functions*

- How to guide a forward state-space search

### 2.6 *Incorporating planning into an actor*

- Online lookahead, unexpected events

### 2.4 *Backward search*

- Start at goal state, go backwards toward initial state

### 2.5 *Plan-space search*

- Start with incomplete plan for getting from initial state to goal state, make transformations to fix flaws in the plan

## Backward Search

- Forward search starts at the initial state
  - Choose applicable action
  - Compute state transition  $s' = \gamma(s, a)$
- Backward search starts at the goal
  - Chooses **relevant** action
    - A possible “last action” before the goal
  - Computes **inverse** state transition  $g' = \gamma^{-1}(g, a)$ 
    - $g'$  = properties a state  $s'$  should satisfy for  $\gamma(s', a)$  to satisfy  $g$
- Sometimes has a lower branching factor

- Example
  - Forward: 7 applicable actions
    - Five load actions, two move actions
  - Backward:  $g = \{loc(r1) = d3\}$ 
    - Two relevant actions:
      - $move(r1, d1, d3),$
      - $move(r1, d2, d3)$

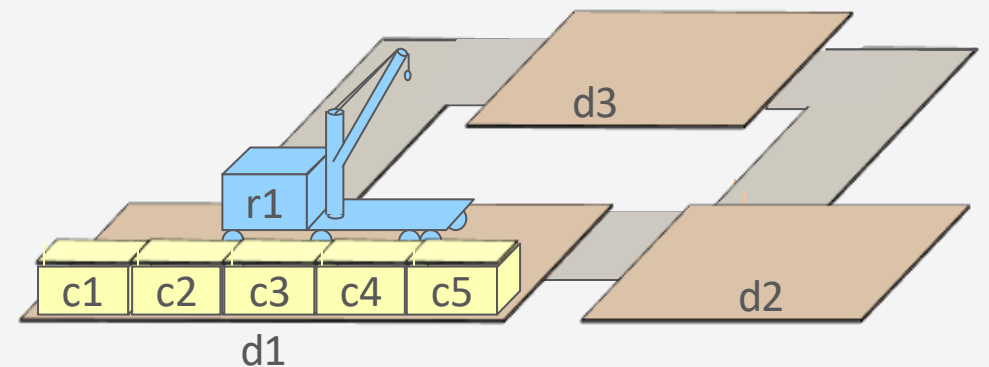

## Relevance

- Idea: when can  $a$  be useful as the last action of a plan  $\pi$  for achieving  $g$ ?
  - $a$  can make at least one atom in  $g$  true that was not true already
  - $a$  does not make any part of  $g$  false

Formally,

- $a$  is **relevant** for  $g = \{x_1 = c_1, \dots, x_k = c_k\}$  if
  - At least one atom in  $g$  is also in  $eff(a)$ 
    - i.e.,  $g$  contains  $x = c$  and  $eff(a)$  contains  $x \leftarrow c$
  - For every atom  $x = c$  in  $g$ 
    - $a$  does not make  $x = c$  false
      - i.e.,  $eff(a)$  doesn't contain  $x \leftarrow c'$  for some  $c' \neq c$
      - if  $pre(a)$  requires  $x = c$  to be false, then  $eff(a)$  makes it true
        - i.e., if  $pre(a)$  contains  $x \neq c$  or  $x = c'$ , then  $eff(a)$  contains  $x \leftarrow c$

## Relevance

- $adj = \{(d1, d2), (d1, d3), (d2, d1), (d2, d3), (d3, d1), (d3, d2)\}$
- $s = \{loc(c1) = d1, loc(c2) = d1, loc(c3) = d1, loc(r1) = d2, cargo(r1) = nil, loc(r2) = d2, cargo(r2) = nil\}$
- $g = \{loc(c1) = r1, loc(r1) = d3\}$
- For each action below, is it relevant for  $g$ ?

- $take(r1, d1, c1)$
- $take(r1, d2, c1)$
- $put(r2, d3, c1)$
- $move(r1, d1, d3)$
- $move(r1, d3, d1)$
- $move(r1, d2, d3)$

$move(r, l, m)$

- pre:  $loc(r) = l, adj(l, m)$
- eff:  $loc(r) \leftarrow m$

$take(r, l, c)$

- pre:  $cargo(r) = nil, loc(r) = l, loc(c) = l$
- eff:  $cargo(r) \leftarrow c, loc(c) \leftarrow r$

$put(r, l, c)$

- pre:  $loc(r) = l, loc(c) = r$
- eff:  $cargo(r) \leftarrow nil, loc(c) \leftarrow l$

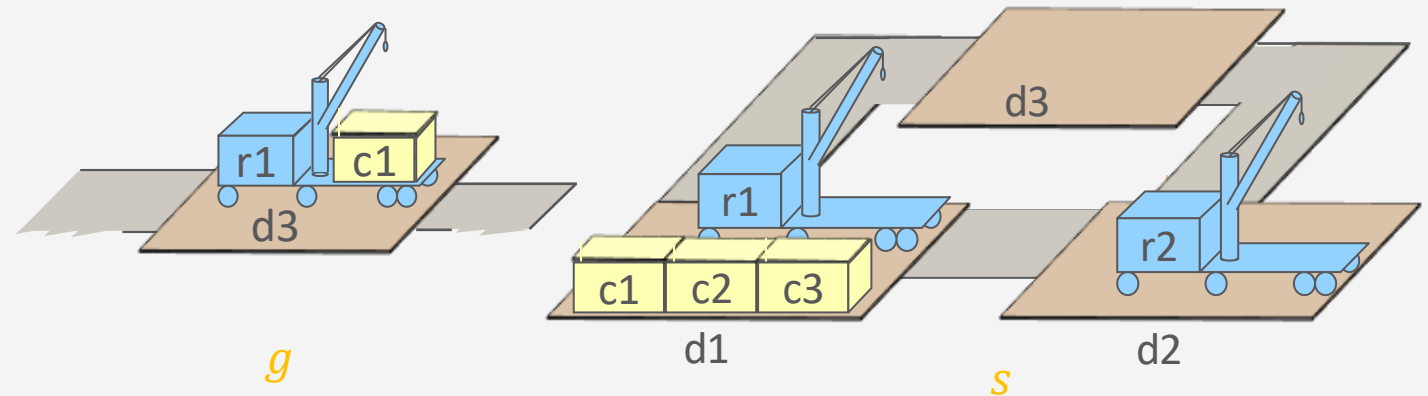

## Inverse State Transitions

- If  $a$  is relevant for  $g$ , then
 
$$\gamma^{-1}(g, a) = pre(a) \cup (g - eff(a))$$
- If  $a$  is not relevant for  $g$ , then  $\gamma^{-1}(g, a)$  is undefined
- Example:
  - $g = \{loc(c1) = r1\}$
  - What is  $\gamma^{-1}(g, take(r1, d3, c1))$ ?
  - What is  $\gamma^{-1}(g, take(r2, d1, c1))$ ?

$move(r, l, m)$

- pre:  $loc(r) = l, adj(l, m)$
- eff:  $loc(r) \leftarrow m$

$take(r, l, c)$

- pre:  $cargo(r) = nil, loc(r) = l, loc(c) = l$
- eff:  $cargo(r) \leftarrow c, loc(c) \leftarrow r$

$put(r, l, c)$

- pre:  $loc(r) = l, loc(c) = r$
- eff:  $cargo(r) \leftarrow nil, loc(c) \leftarrow l$

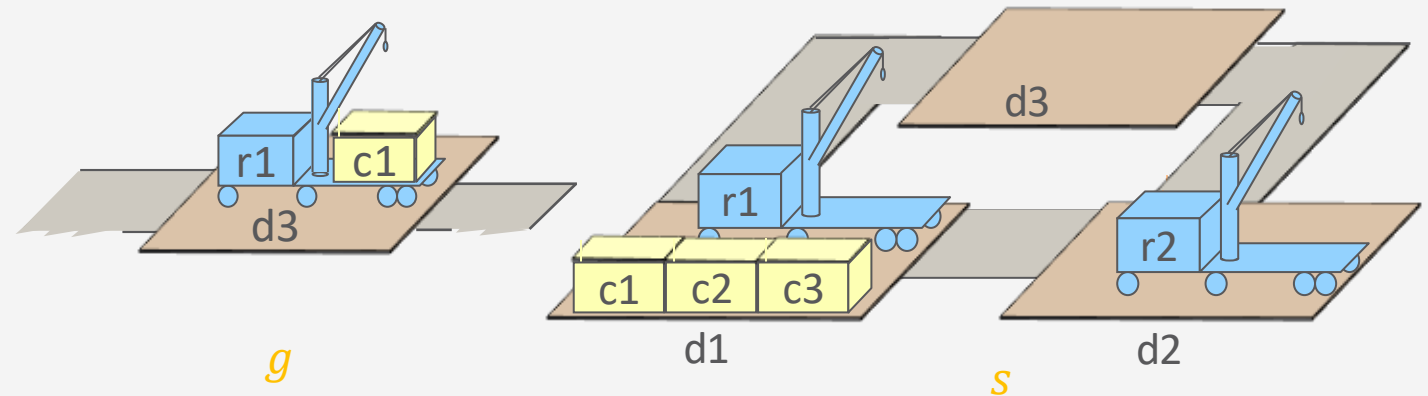

## Backward Search

- Cycle checking:
  - After line (i), put  $Solved \leftarrow \{g\}$
  - After line (ii), put either of the following two:
    - if  $g \in Solved$  then  
return failure  
 $Solved \leftarrow Solved \cup \{g\}$
    - if  $\exists g' \in Solved : g' \subseteq g$  then  
return failure  
 $Solved \leftarrow Solved \cup \{g\}$
- With cycle checking, sound and complete
  - If  $(\Sigma, s_0, g_0)$  is solvable, then at least one of the execution traces will find a solution

**Backward-search**  $(\Sigma, s_0, g_0)$

$g \leftarrow g_0$

$\pi \leftarrow \langle \rangle$  (i)

**loop**

**if**  $s_0$  satisfies  $g$  **then**

**return**  $\pi$

$A' \leftarrow \{a \in A \mid a \text{ is relevant for } g\}$

**if**  $A' = \emptyset$  **then**

**return** failure

nondeterministically choose  $a \in A'$

$g \leftarrow \gamma^{-1}(g, a)$

$\pi \leftarrow a.\pi$  (ii)

**Input:**

- Planning problem  $(\Sigma, s_0, g)$

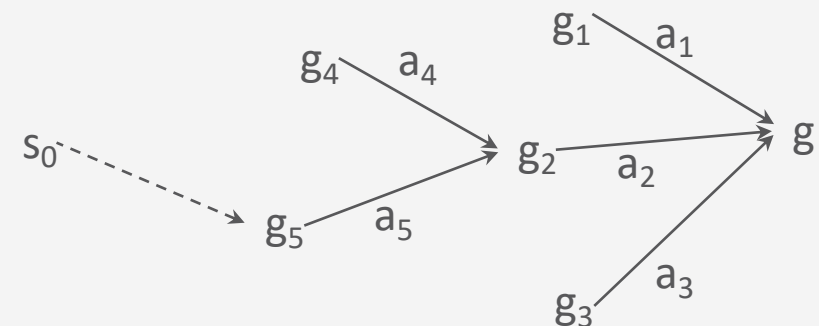

## Branching Factor

- Motivation for Backward-search was to reduce the branching factor
  - As written, does not accomplish that
- Solve this by **lifting**:
  - When possible, leave variables uninstantiated

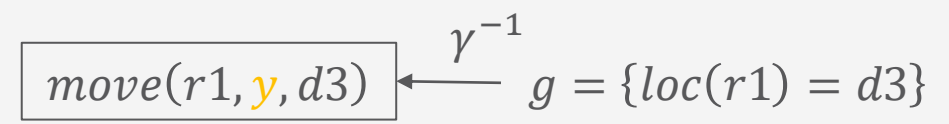
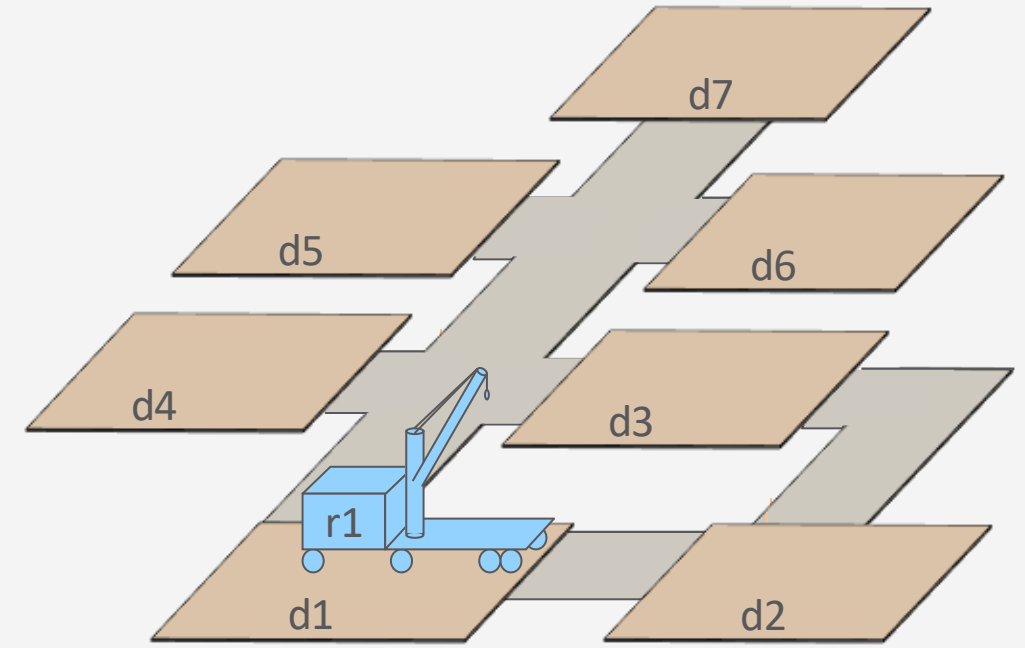
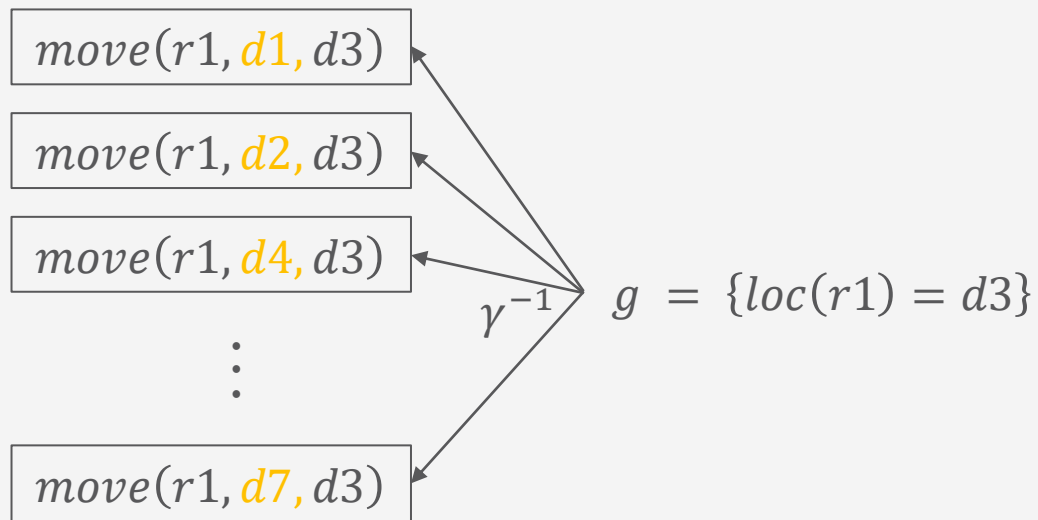

## Lifted Backward Search

- Like Backward-search but much smaller branching factor
  - Keep track of what values were substituted for which parameters
  - I will not discuss the details
  - Plan-space planning (next) does something similar

### Backward-search ( $\Sigma, s_0, g_0$ )

```

g ← g0
π ← ⟨⟩
loop
  if s0 satisfies g then
    return π
  A' ← {a ∈ A | a is relevant for g}
  if A' = ∅ then
    return failure
  nondeterministically choose a ∈ A'
  g ← γ-1(g, a)
  π ← a.π

```

### Lifted-Backward-search ( $\mathcal{A}, s_0, g$ )

```

π ← ⟨⟩
loop
  if s0 satisfies g then
    return π
  A ← {(a, θ) | a is a standardisation of an action template in  $\mathcal{A}$ ,
           θ is an mgu for an atom of g and an atom of eff+(a), and
           γ-1(θ(g), θ(a)) is defined}
  if A = ∅ then
    return failure
  nondeterministically choose (a, θ) ∈ A
  g ← γ-1(θ(g), θ(a)), π ← a.π

```

## Intermediate Summary

- Backward State-space Search
  - Relevance, inverse state transition  $\gamma^{-1}$
  - Backward search, cycle checking
  - Lifted backward search (briefly)

## Outline per the Book

### 2.1 *State-variable representation*

- State = {values of variables}; action = changes to those values

### 2.2 *Forward state-space search*

- Start at initial state, look for sequence of actions that achieve goal

### 2.3 *Heuristic functions*

- How to guide a forward state-space search

### 2.6 *Incorporating planning into an actor*

- Online lookahead, unexpected events

### 2.4 *Backward search*

- Start at goal state, go backwards toward initial state

### 2.5 *Plan-space search*

- Start with incomplete plan for getting from initial state to goal state, make transformations to fix flaws in the plan

## Plan-Space Search

- Formulate planning as a constraint satisfaction problem (CSP)
  - Use constraint-satisfaction techniques to produce solutions that are more flexible than ordinary plans
    - E.g., plans in which the actions are partially ordered
    - Postpone ordering decisions until the plan is being executed
      - The actor may have a better idea about which ordering is best
- First step toward temporal planning (Chapter 4 in book)
- Basic idea:
  - Backward search from the goal
  - Each node of the search space is a **partial plan** that contains **flaws**
    - Remove the flaws by making **refinements**
  - If successful, we will get a **partially ordered** solution

## Definitions

- **Partially ordered plan**
  - Partially ordered set of nodes
  - Each node contains an action
- **Partially ordered solution**
  - Partially ordered plan  $\pi$  such that every total ordering of  $\pi$  is a solution
- **Partial plan**
  - Partially ordered set of nodes that contain **partially instantiated** actions
  - **Inequality constraints**
    - E.g.,  $z \neq x$  or  $w \neq p1$
  - **Causal links** (dashed arcs)
    - Use action  $a$  to establish precondition  $p$  of action  $b$

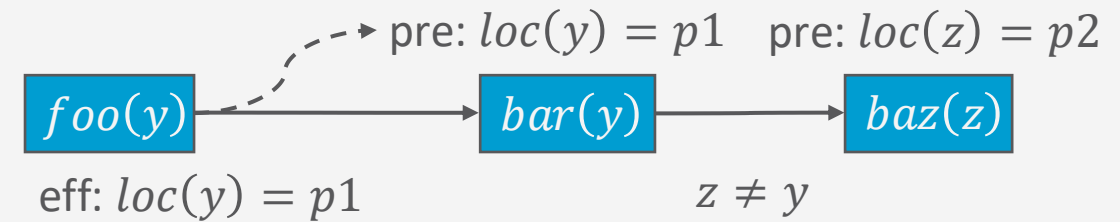
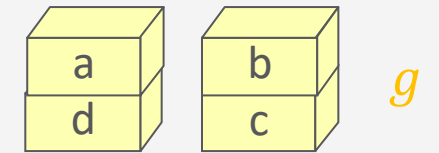
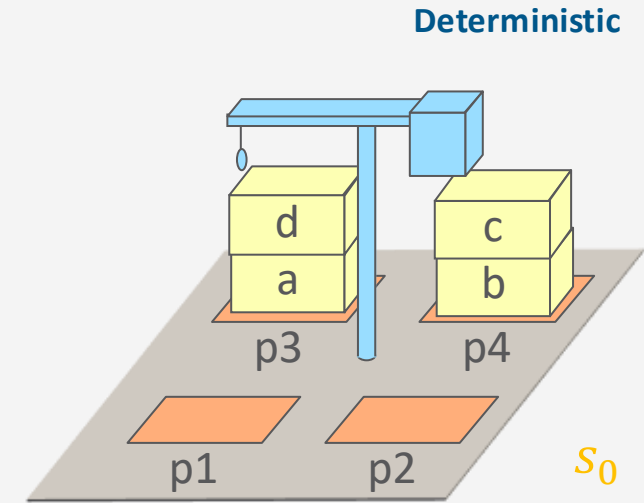
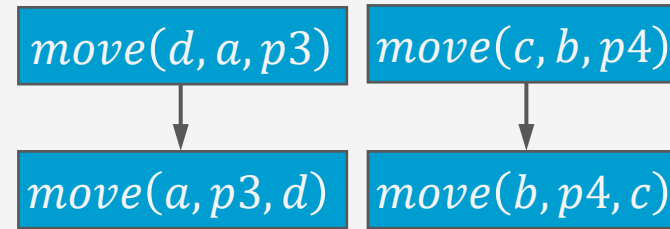

## Flaws: 1. Open Goals

- A precondition  $p$  of an action  $b$  is an **open goal** if there is no causal link for  $p$
- Resolve the flaw by creating a causal link
  - Find an action  $a$  (either already in  $\pi$ , or can add it to  $\pi$ ) that can establish  $p$ 
    - Can precede  $b$
    - Can have  $p$  as an effect
  - Do substitutions on variables to make  $a$  assert  $p$ 
    - E.g., replace  $x$  with  $y$
  - Add an ordering constraint  $a < b$
  - Create a causal link from  $a$  to  $p$

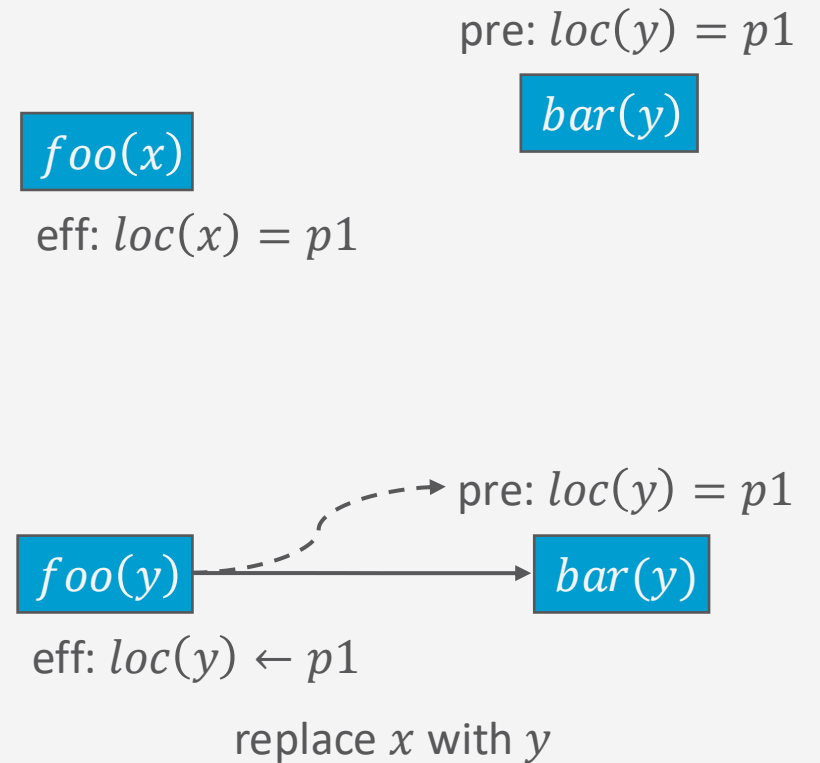

## Flaws: 2. Threats

- Suppose we have a causal link from action  $a$  to precondition  $p$  of action  $b$
- Action  $c$  **threatens** the link if  $c$  may affect  $p$  and may come between  $a$  and  $b$ 
  - **$c$  is a threat** even if it makes  $p$  true rather than false
    - Causal link means  $a$ , not  $c$ , is supposed to establish  $p$  for  $b$
    - Plan in which  $c$  establishes  $p$  will be generated on another path in the search space
- Three possible ways to resolve the flaw:
  - Make  $c < a$
  - Make  $b < c$
  - Add inequality constraints to prevent  $c$  from affecting  $p$

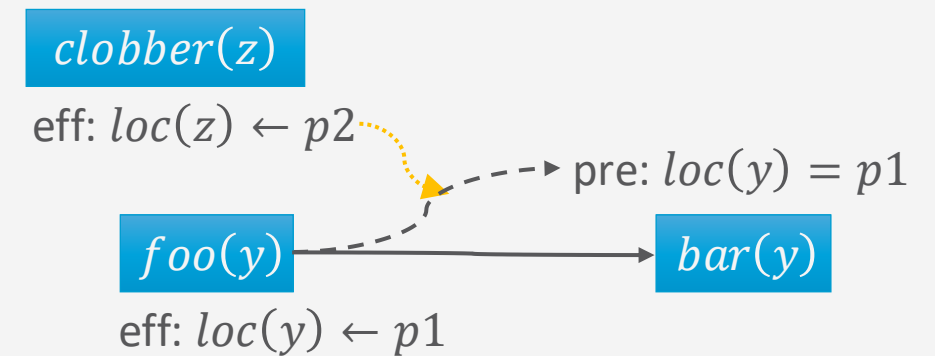

# PSP Algorithm

- Initial plan is always  $\{Start, Finish\}$  with  $Start \prec Finish$ 
  - Start
    - No preconditions
    - Effects: atoms in  $s_0$
  - Finish
    - Preconditions: atoms in  $g$
    - No effects
- PSP is sound and complete
  - Returns a partially ordered plan  $\pi$  s.t. any total ordering of  $\pi$  will achieve  $g$
  - In some environments, could execute actions in parallel

```

PSP ( $\Sigma, \pi$ )
  loop
    if  $Flaws(\pi) = \emptyset$  then
      return  $\pi$ 
    arbitrarily select  $f \in Flaws(\pi)$ 
     $R \leftarrow \{\text{all feasible resolvers for } f\}$ 
    if  $R = \emptyset$  then
      return failure
    nondeterministically choose  $\rho \in R$ 
     $\pi \leftarrow \rho(\pi)$ 
  
```

Inputs:

- Planning domain  $\Sigma$
- Initial plan  $\pi$



# Example

- Finish has two open goals:  
 $\text{pos}(a)=d$ ,  $\text{pos}(b)=c$

```
loop
  if  $Flaws(\pi) = \emptyset$  then
    return  $\pi$ 
  arbitrarily select  $f \in Flaws(\pi)$ 
   $R \leftarrow \{\text{all feasible resolvers for } f\}$ 
  if  $R = \emptyset$  then
    return failure
  nondeterministically choose  $\rho \in R$ 
   $\pi \leftarrow \rho(\pi)$ 
```

$\text{move}(c, y, z)$

pre:  $\text{pos}(c)=y$ ,  $\text{clear}(c)=T$ ,  $\text{clear}(z)=T$

eff:  $\text{pos}(c) \leftarrow z$ ,  $\text{clear}(y) \leftarrow T$ ,  $\text{clear}(z) \leftarrow F$

$\text{ran}(c) = \text{Containers}$

$\text{ran}(y) = \text{ran}(z) = \text{Container} \cup \text{pallets}$

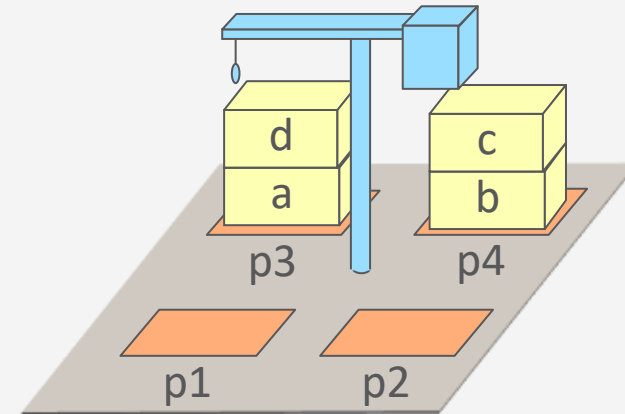

Start

$\text{clear}(p1)=T$   $\text{clear}(p2)=T$   $\text{clear}(p3)=F$   $\text{clear}(p4)=F$   
 $\text{clear}(a)=F$   $\text{clear}(b)=F$   $\text{clear}(c)=T$   $\text{clear}(d)=T$   
 $\text{pos}(a)=p3$   $\text{pos}(b)=p4$   $\text{pos}(c)=b$   $\text{pos}(d)=a$

$\text{pos}(a)=d$   $\text{pos}(b)=c$

Finish

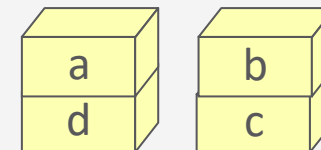

# Example

- For each open goal, add a new action
- Every new action  $a$  must have  $Start < a < Finish$

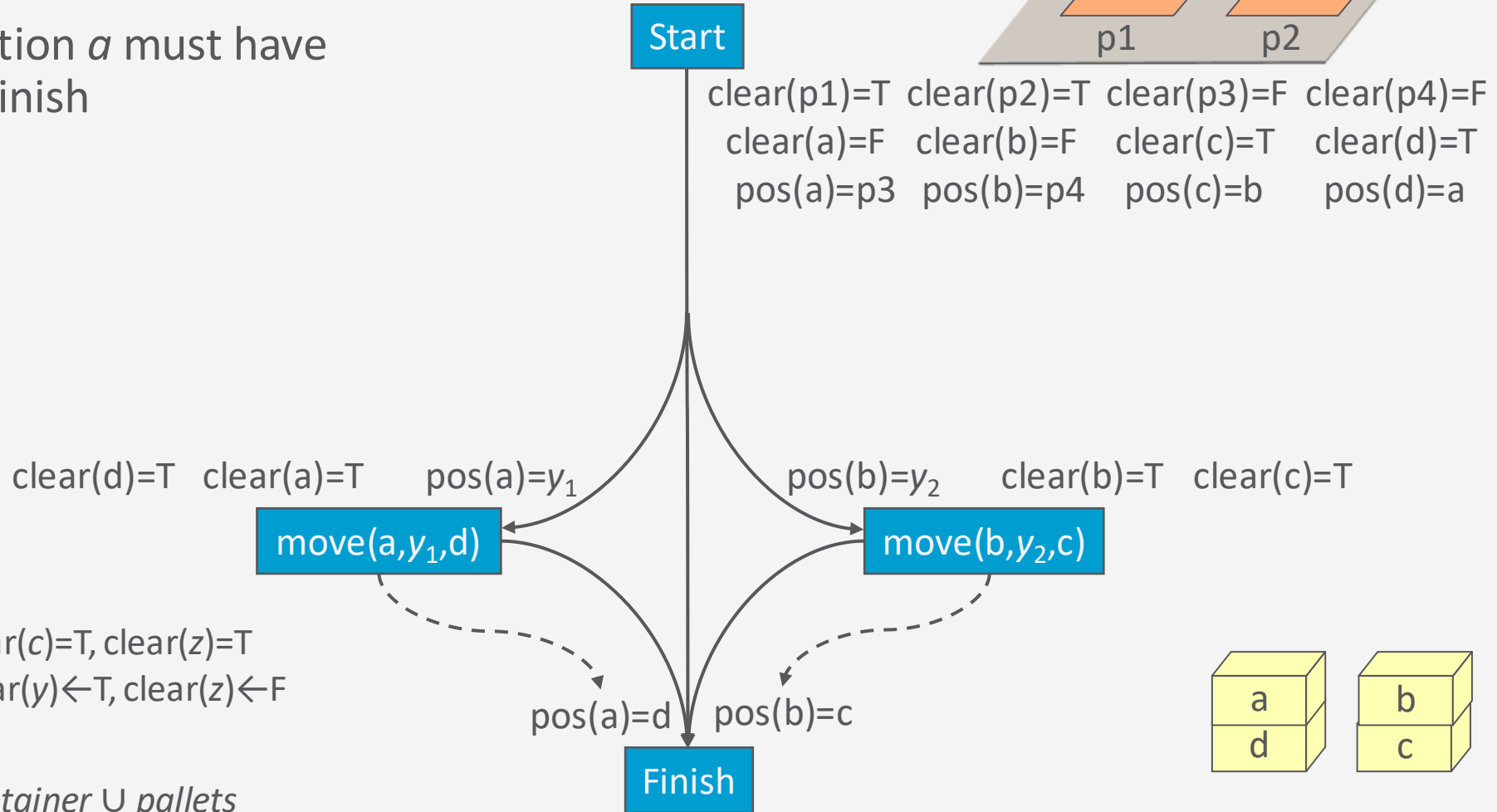
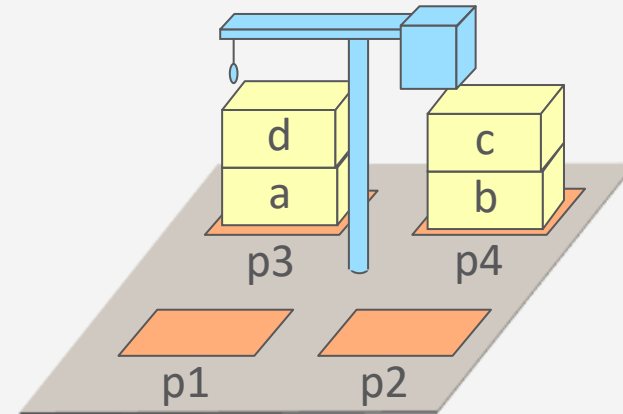

# Example

- Resolve four open goals using the Start action
- Substitute  $y_1=p3$ ,  $y_2=p4$

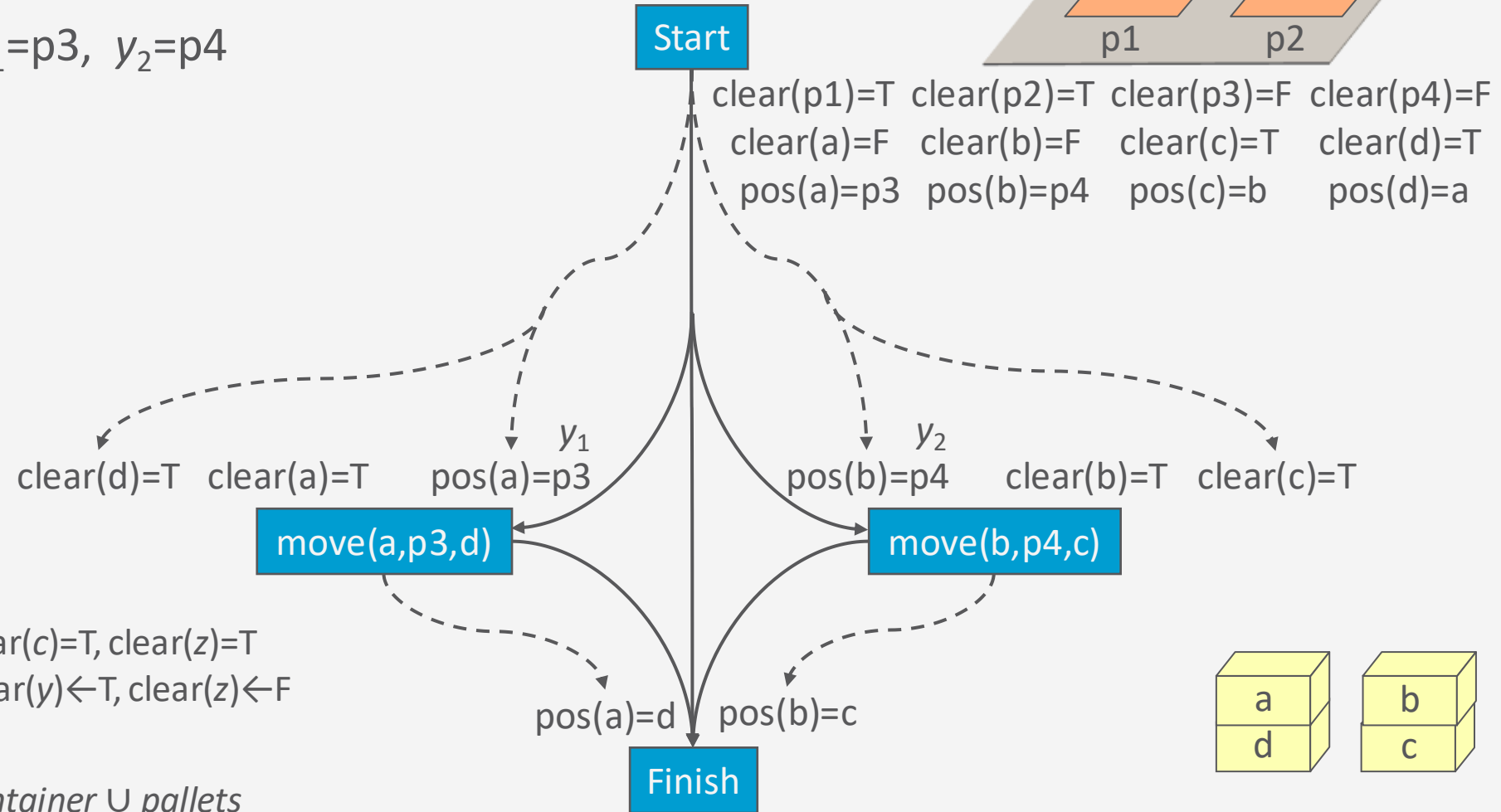
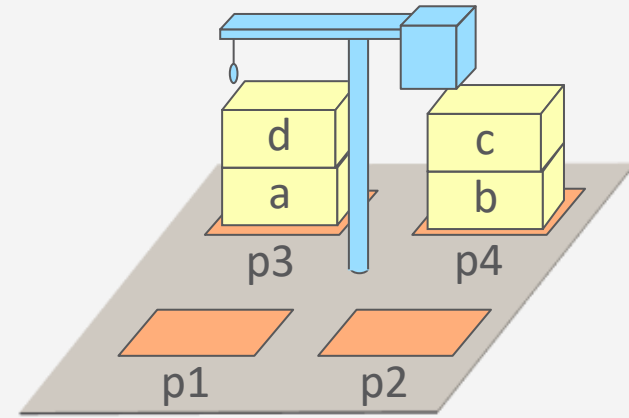

# Example

- New action to resolve open goal
- 1<sup>st</sup> threat has one resolver:  $z_3 \neq d$
- 2<sup>nd</sup> threat has two resolvers:
  - $move(b, p4, c) < move(x_3, a, z_3)$
  - $z_3 \neq c$

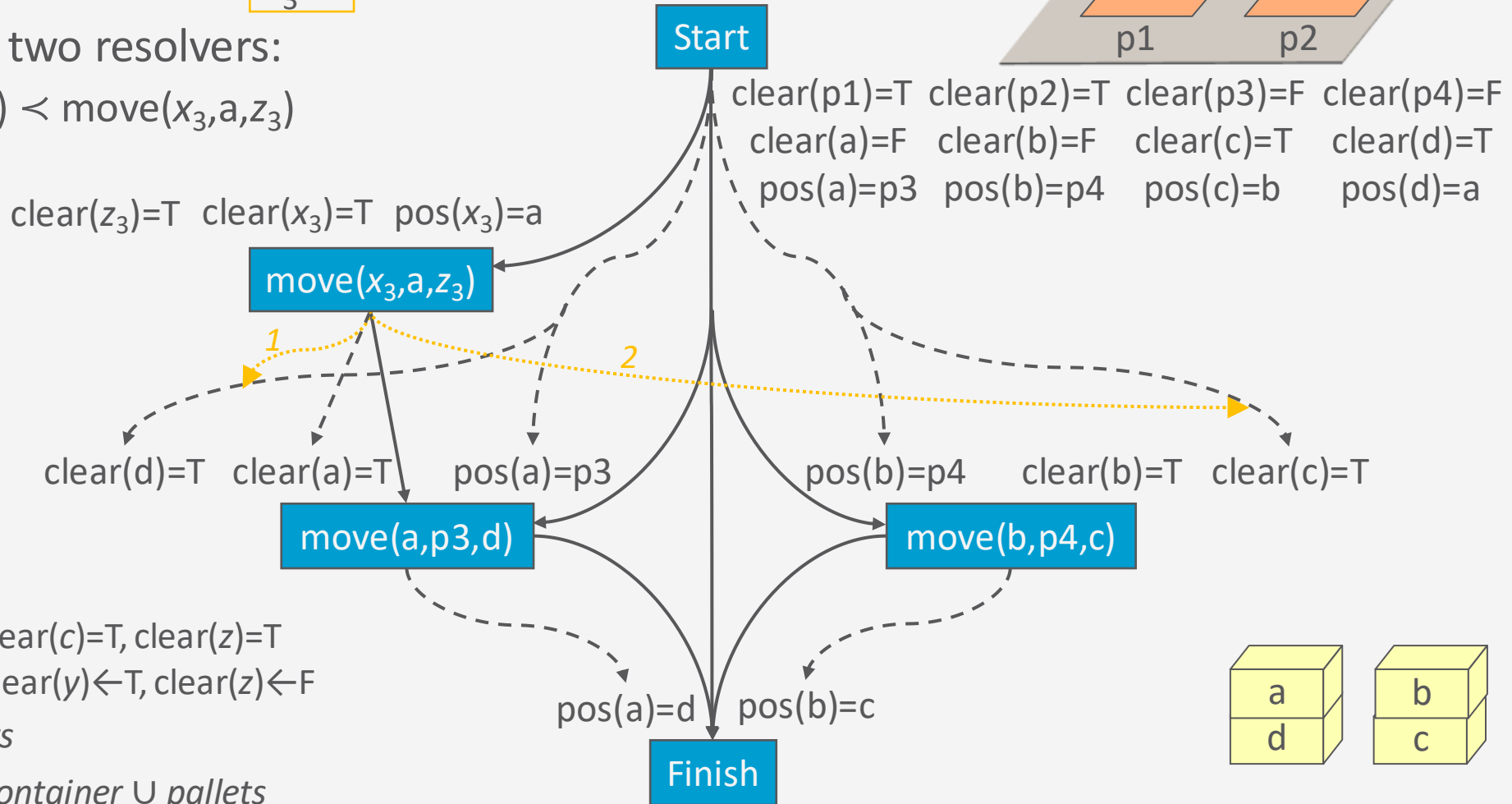
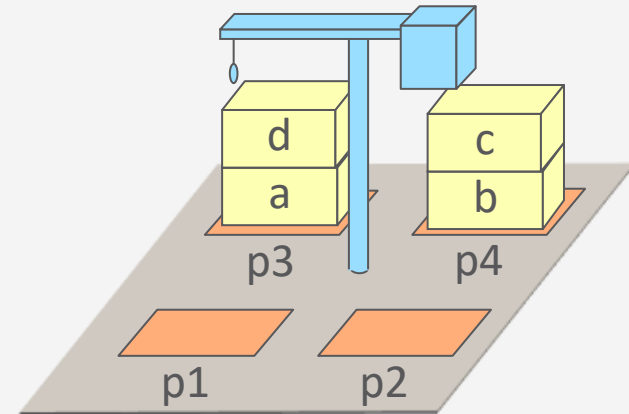

# Example

- Threats resolved

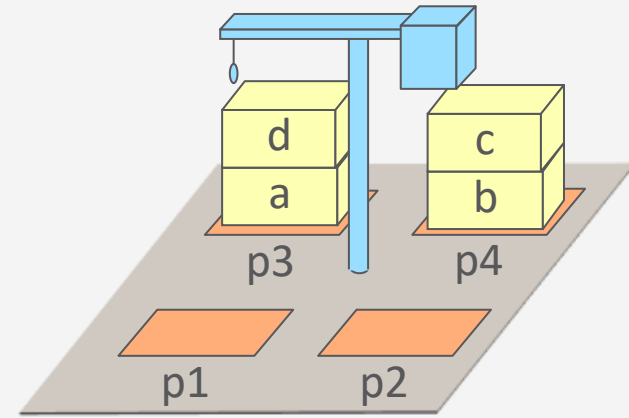

$z_3 \neq c$   
 $z_3 \neq d$

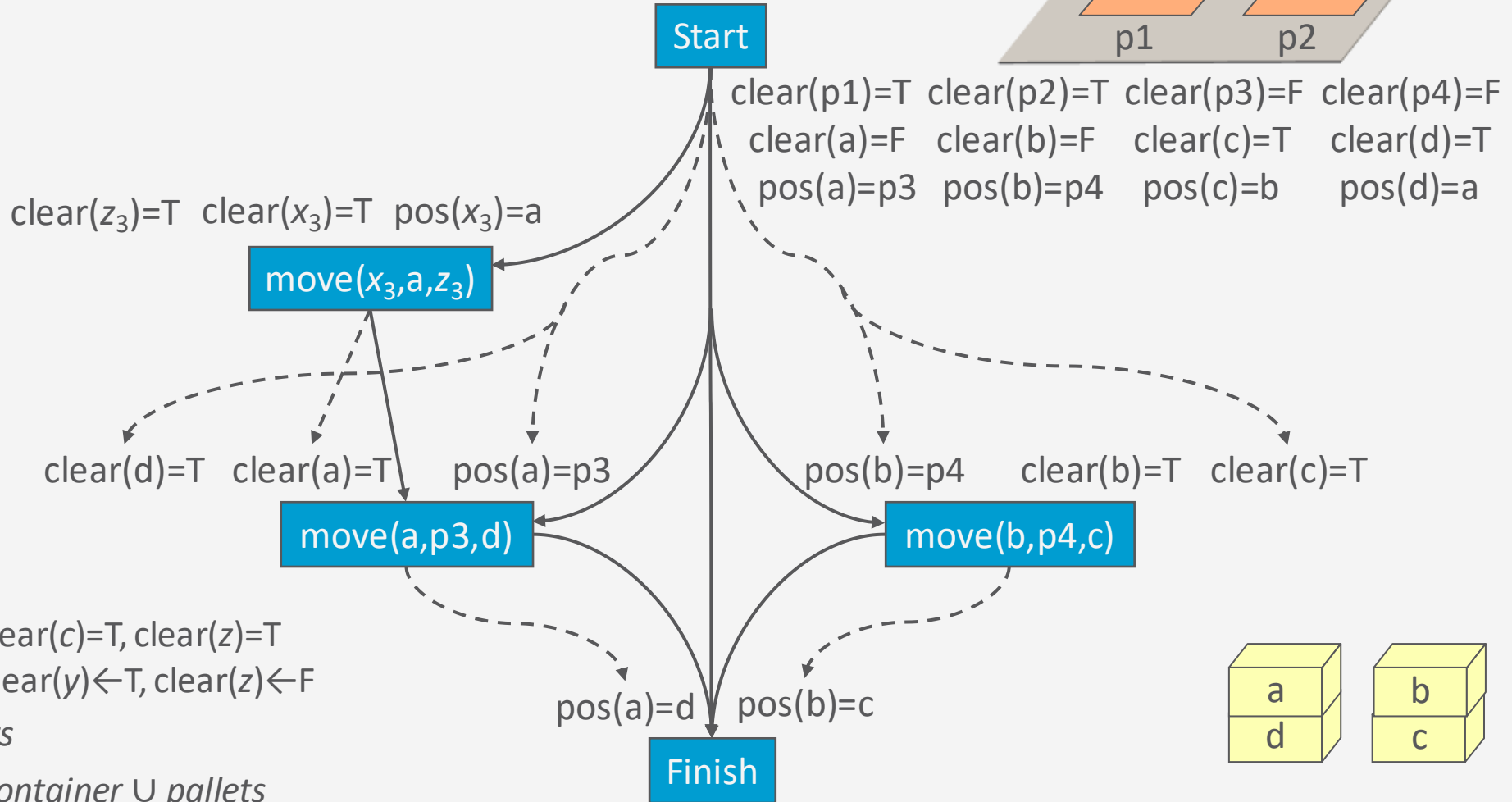

# Example

- 1<sup>st</sup> threat has two resolvers:
  - An ordering constraint, and  $z_4 \neq d$
- 2<sup>nd</sup> threat has three resolvers:
  - Two ordering constraints, and  $z_4 \neq a$
- 3<sup>rd</sup> threat has one:  $z_4 \neq c$

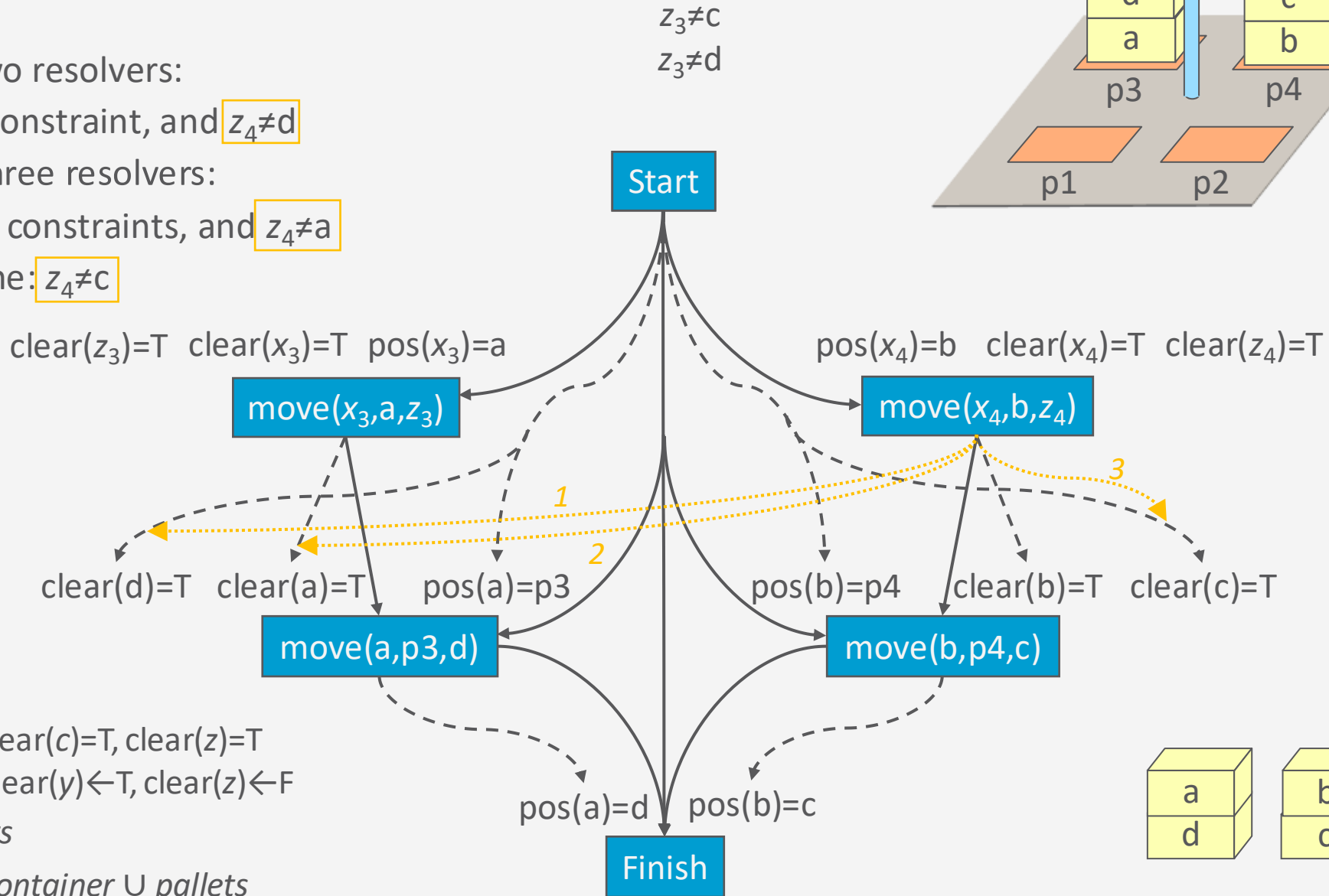
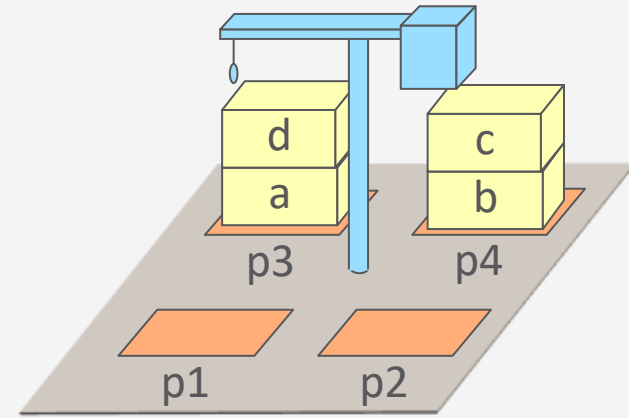

move( $c, y, z$ )  
 pre: pos( $c$ )= $y$ , clear( $c$ )=T, clear( $z$ )=T  
 eff: pos( $c$ ) $\leftarrow$  $z$ , clear( $y$ ) $\leftarrow$ T, clear( $z$ ) $\leftarrow$ F  
 ran( $c$ ) = Containers  
 ran( $y$ ) = ran( $z$ ) = Container  $\cup$  pallets

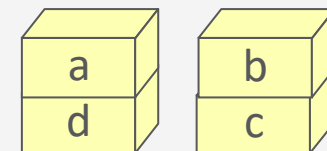

# Example

- Resolve the three threats using inequality constraints

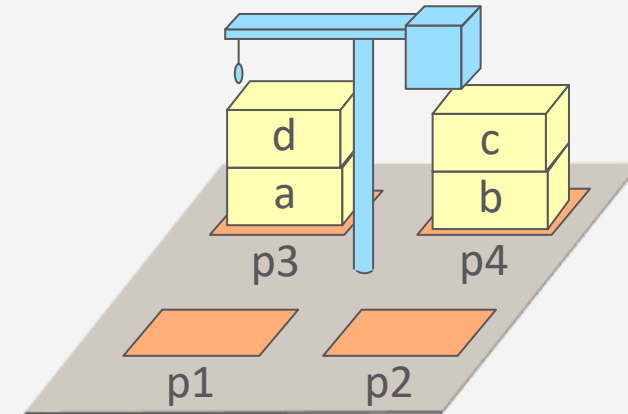

$z_3 \neq c$      $z_4 \neq a$   
 $z_3 \neq d$      $z_4 \neq c$   
 $z_4 \neq d$

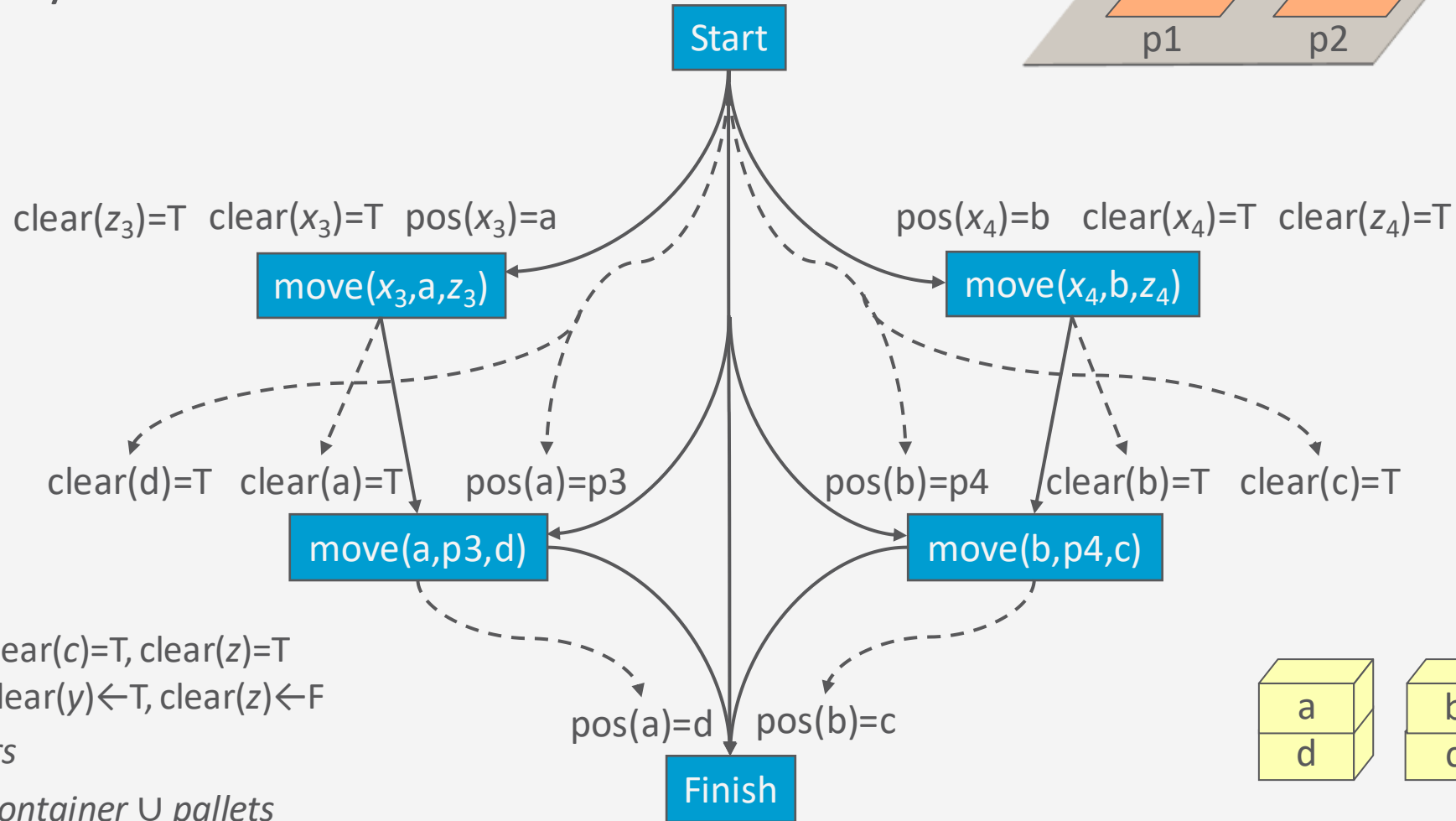

move( $c, y, z$ )  
 pre: pos( $c$ )= $y$ , clear( $c$ )=T, clear( $z$ )=T  
 eff: pos( $c$ ) $\leftarrow$  $z$ , clear( $y$ ) $\leftarrow$ T, clear( $z$ ) $\leftarrow$ F  
 ran( $c$ ) = Containers  
 ran( $y$ ) = ran( $z$ ) = Container  $\cup$  pallets

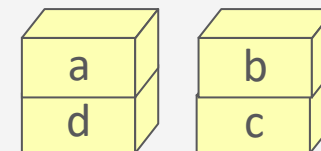

# Example

- Resolve five open goals using the Start action

- Substitute  $x_3=d, x_4=c, z_3=p1$

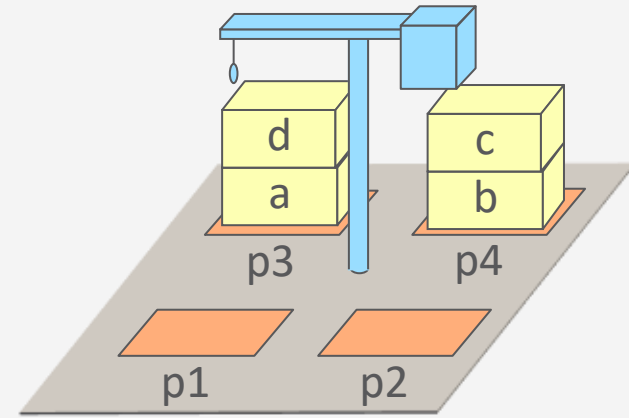

$z_3 \neq c$      $z_4 \neq a$   
 $z_3 \neq d$      $z_4 \neq c$   
 satisfied     $z_4 \neq d$

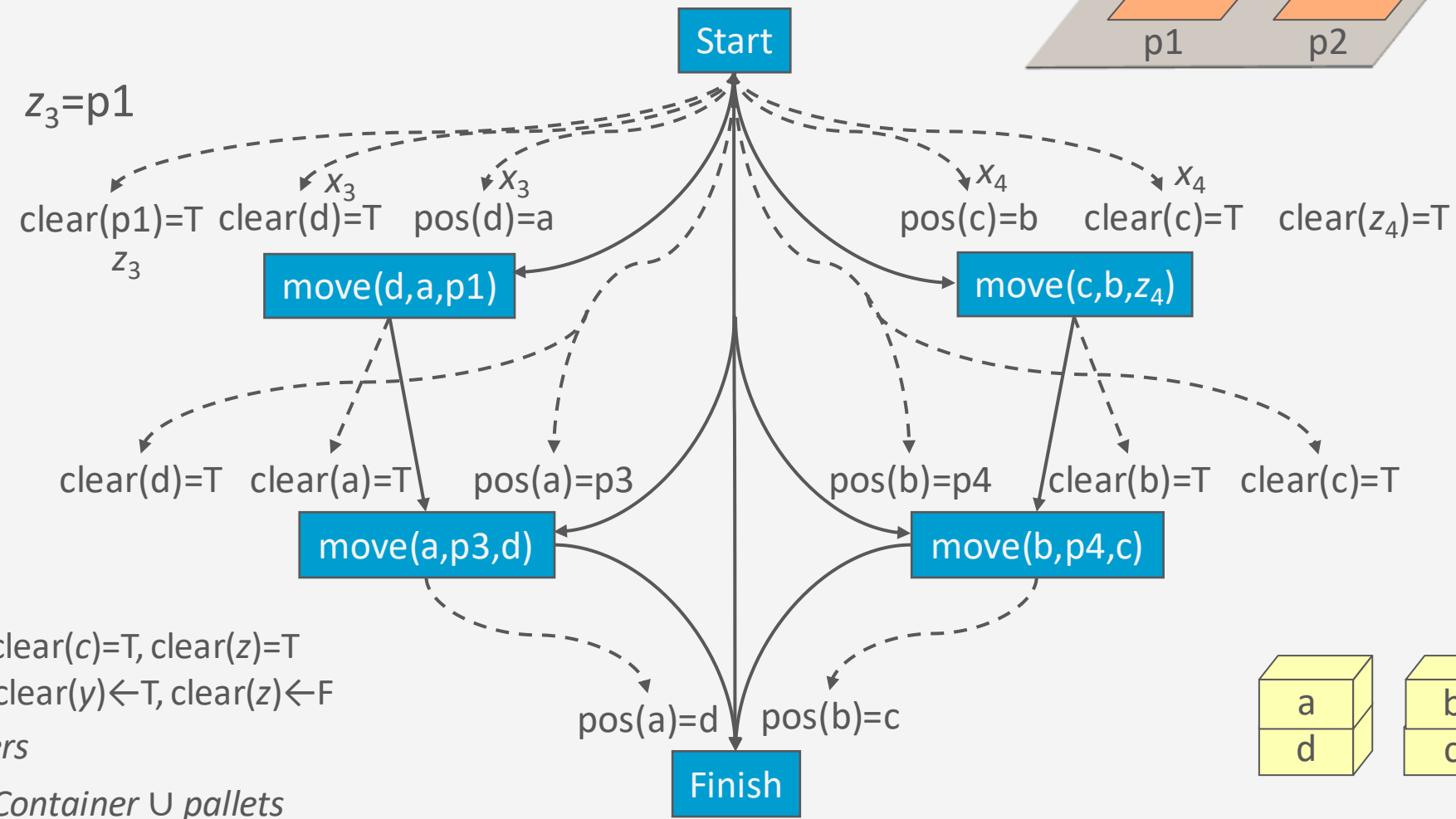

$move(c, y, z)$   
 pre:  $pos(c)=y, clear(c)=T, clear(z)=T$   
 eff:  $pos(c) \leftarrow z, clear(y) \leftarrow T, clear(z) \leftarrow F$   
 $ran(c) = Containers$   
 $ran(y) = ran(z) = Container \cup pallets$

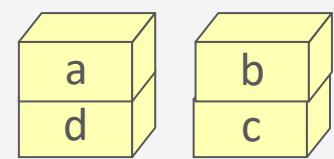

# Example

- Threatened causal link
- Resolvers:

- $\text{move}(d,a,p1) < \text{move}(c,b,z_4)$
- $z_4 \neq p1$

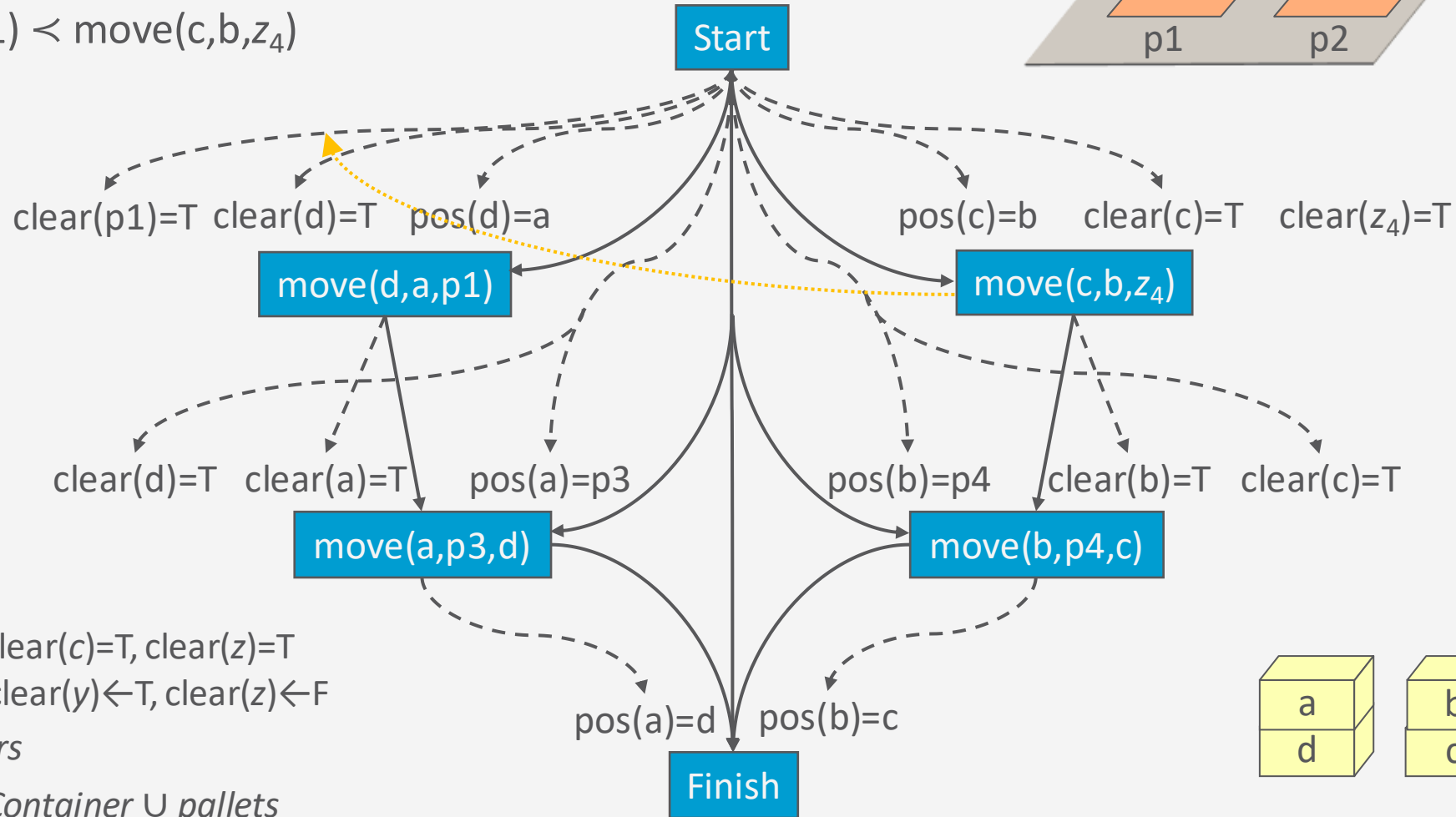
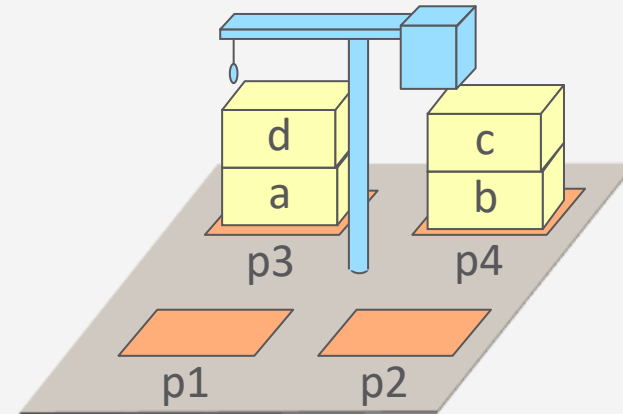

$\text{move}(c, y, z)$   
 pre:  $\text{pos}(c)=y, \text{clear}(c)=T, \text{clear}(z)=T$   
 eff:  $\text{pos}(c) \leftarrow z, \text{clear}(y) \leftarrow T, \text{clear}(z) \leftarrow F$   
 $\text{ran}(c) = \text{Containers}$   
 $\text{ran}(y) = \text{ran}(z) = \text{Container} \cup \text{pallets}$

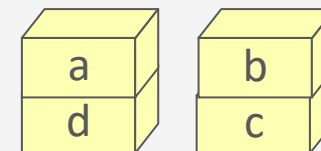

# Example

- Threat resolved

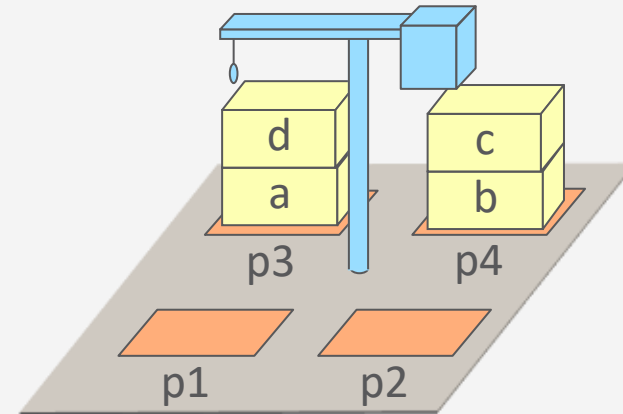

$z_4 \neq a$   
 $z_4 \neq c$   
 $z_4 \neq d$   
 $z_4 \neq p1$

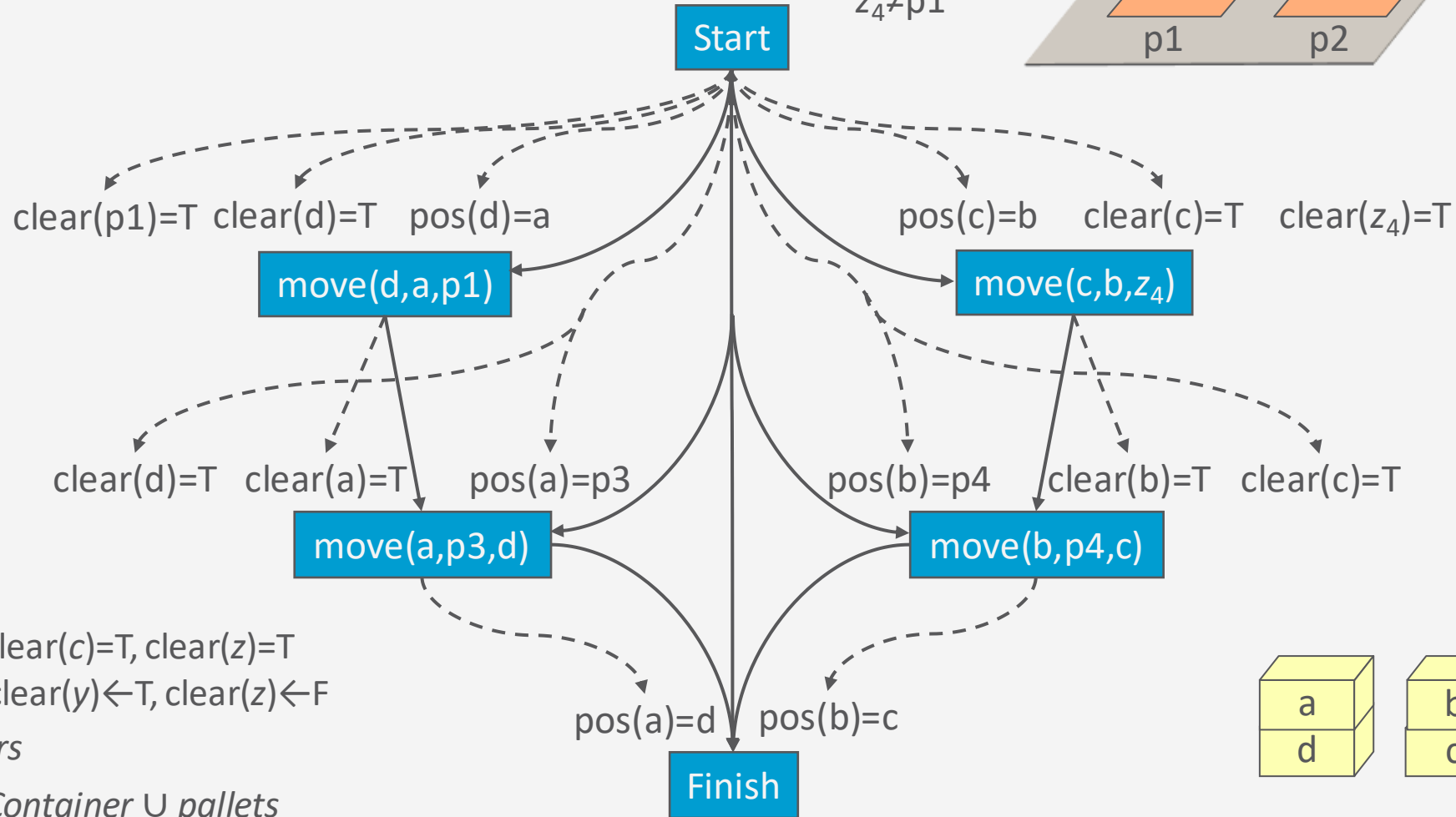

move(c, y, z)  
 pre: pos(c)=y, clear(c)=T, clear(z)=T  
 eff: pos(c)←z, clear(y)←T, clear(z)←F  
 ran(c) = Containers  
 ran(y) = ran(z) = Container ∪ pallets

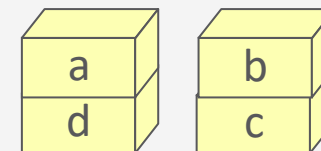

# Example

- Resolve open goal using the Start action
  - substitute  $z_4 = p2$
- No more flaws, so we are done!

$z_4 \neq a$   
 $z_4 \neq c$   
 $z_4 \neq d$   
 $z_4 \neq p1$   
 satisfied

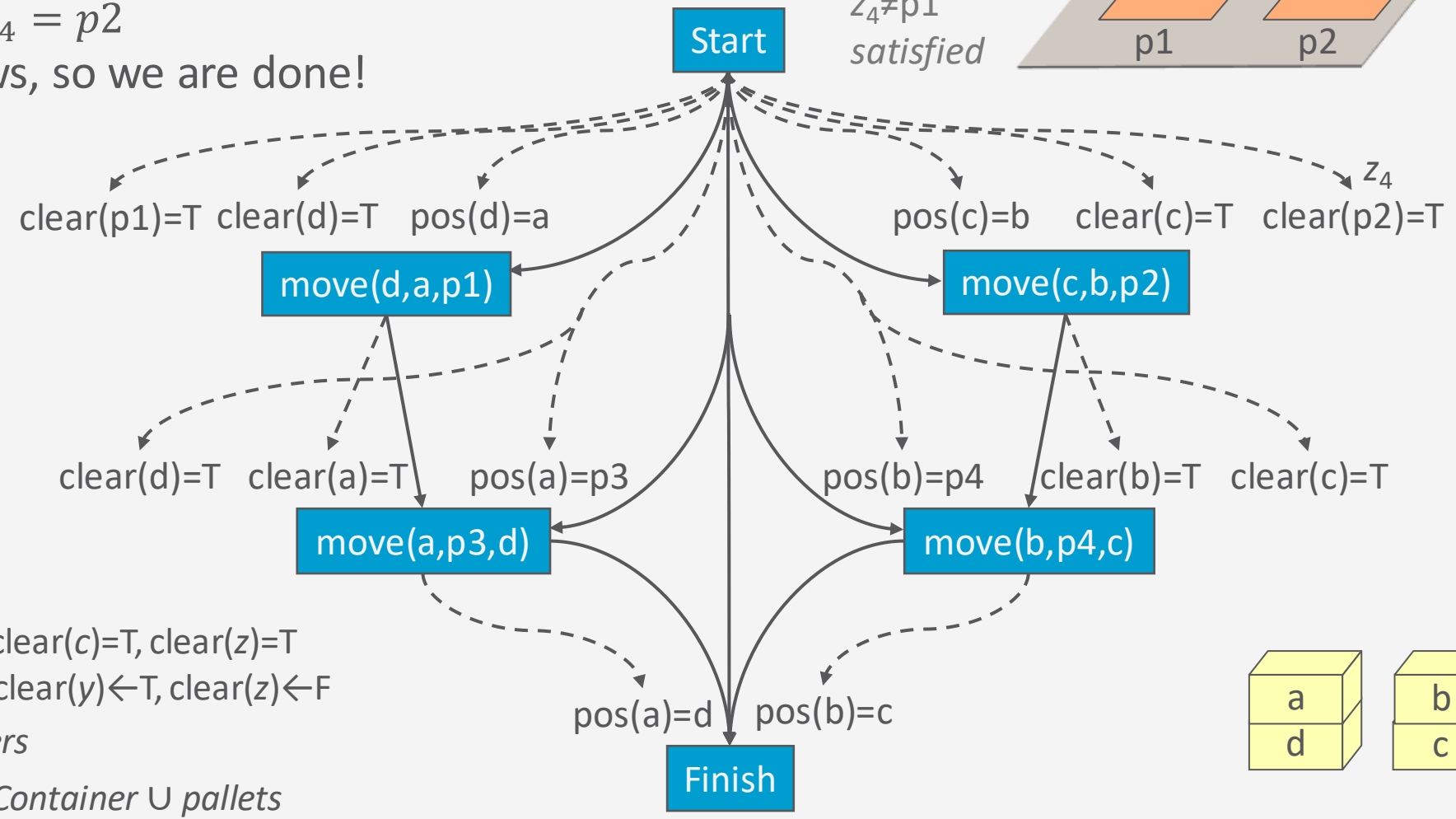
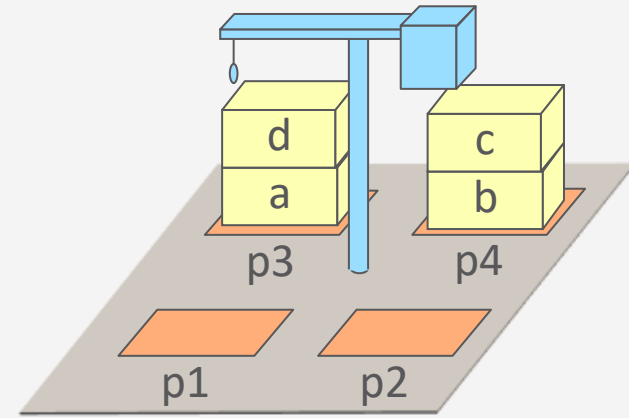

move(c, y, z)  
 pre: pos(c)=y, clear(c)=T, clear(z)=T  
 eff: pos(c)←z, clear(y)←T, clear(z)←F  
 ran(c) = Containers  
 ran(y) = ran(z) = Container U pallets

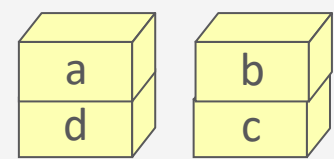

# Example

- PSP returns this solution:

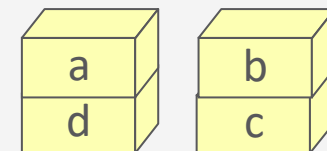
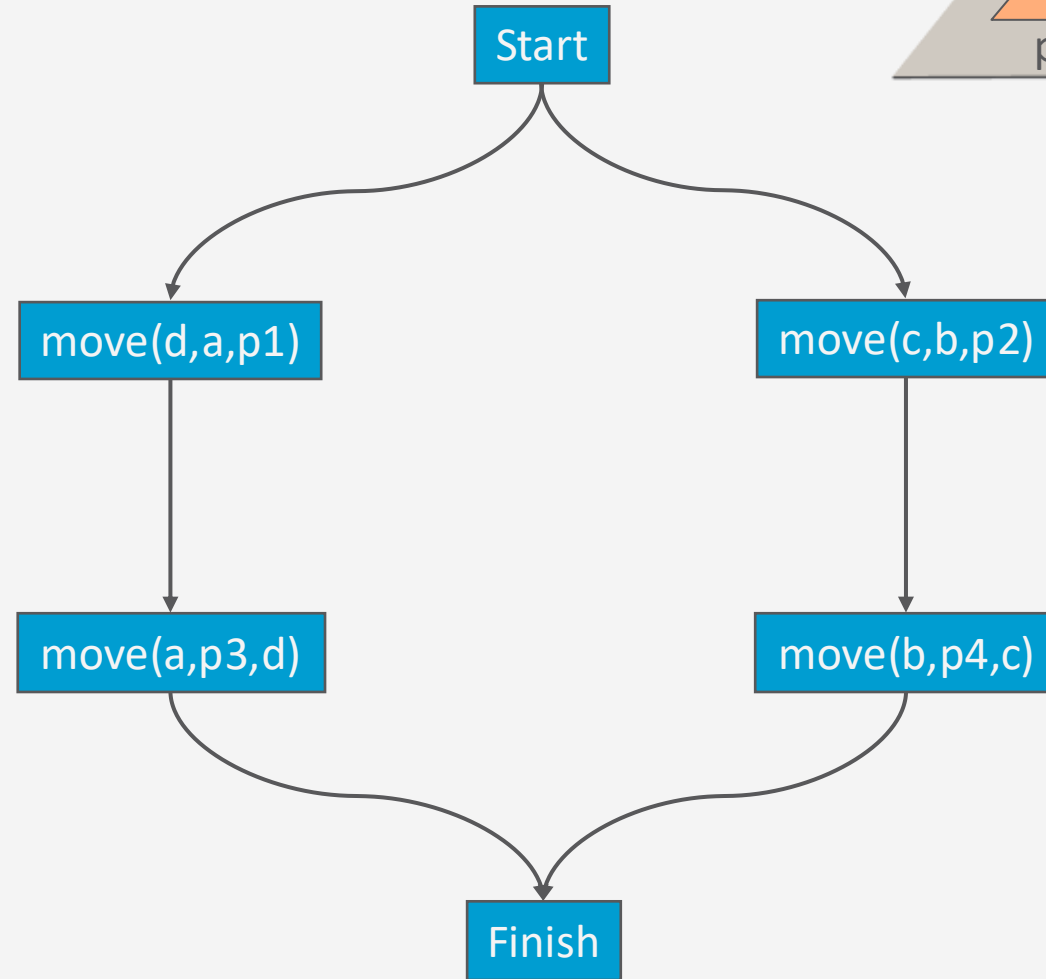
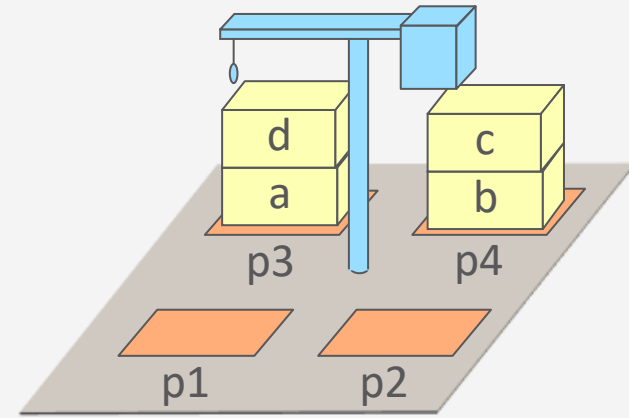

## Example 2

- Go back to the last threat, choose the other resolver:

- $move(d, a, p1) < move(c, b, z_4)$

- $z_4 \neq p1$

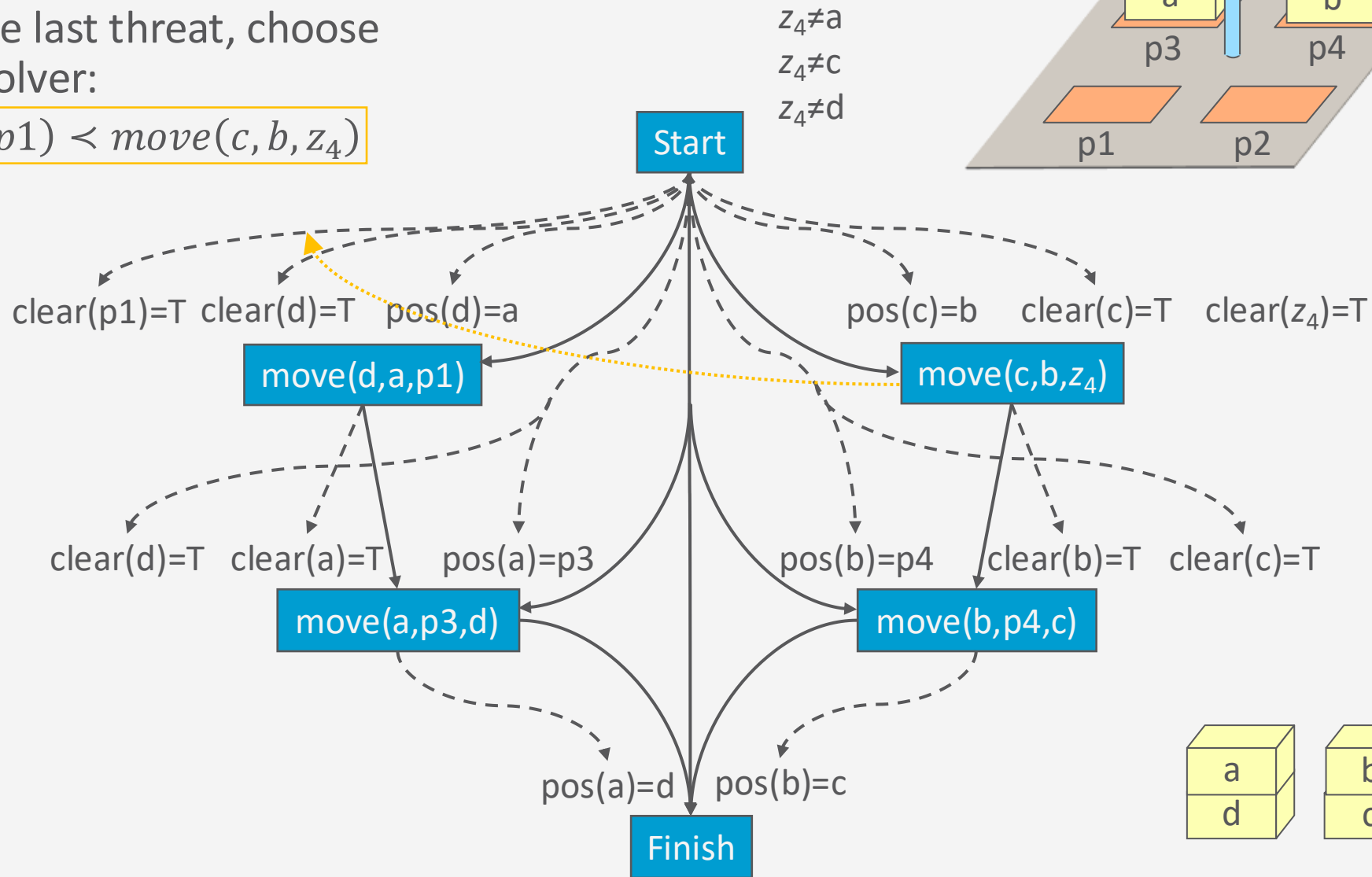
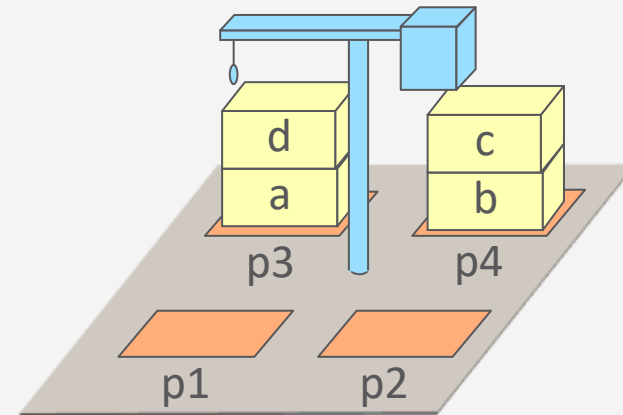

# Example 2

- Threat resolved

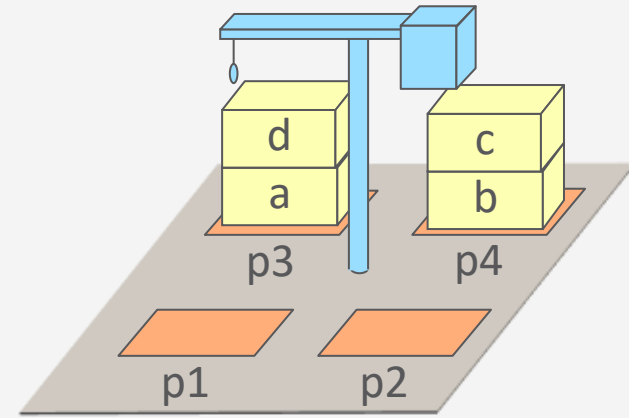

$z_4 \neq a$   
 $z_4 \neq c$   
 $z_4 \neq d$

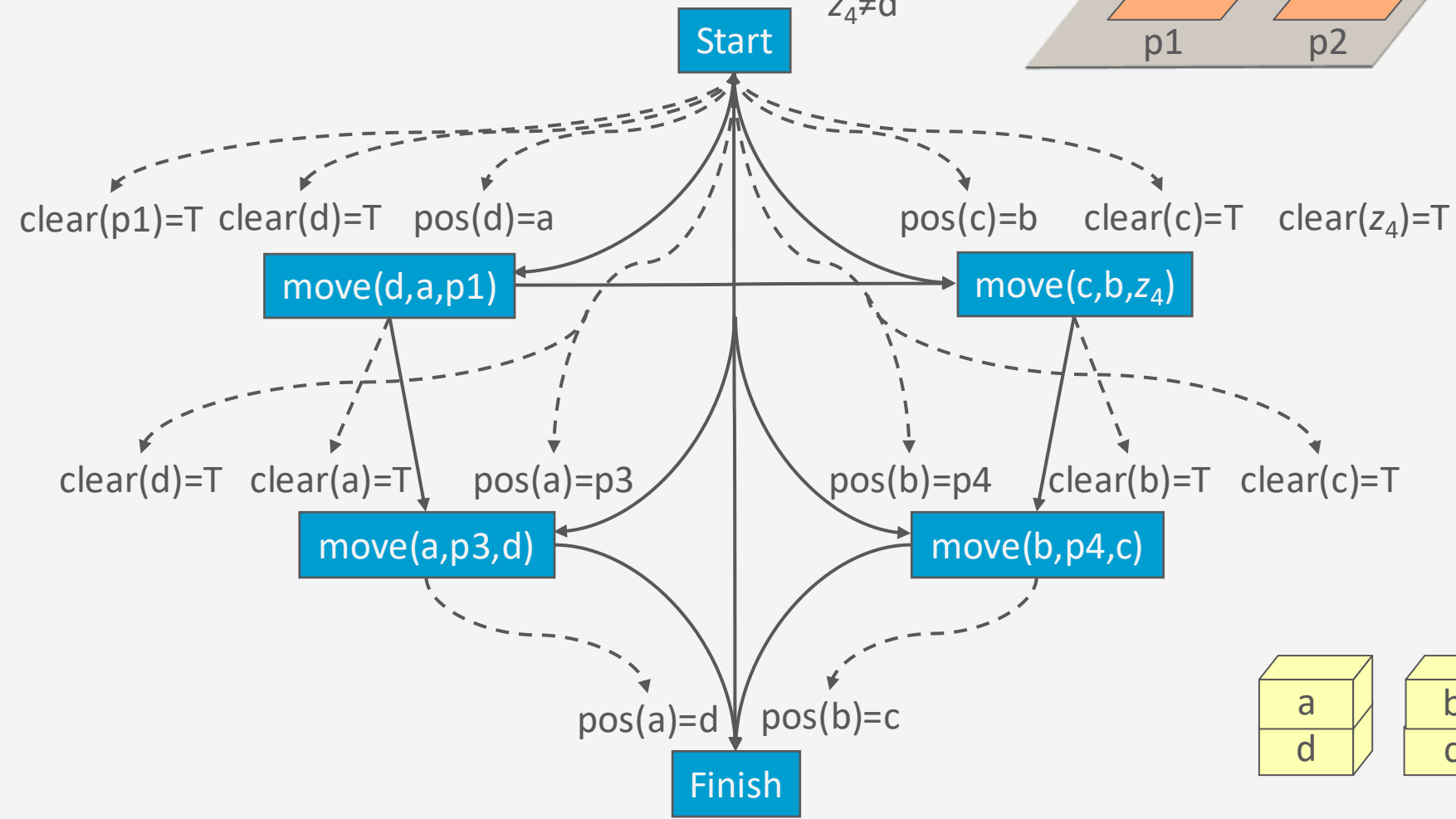

# Example 2

- Resolve open goal
- Substitute  $z_4 = p2$
- No more flaws, so we are done

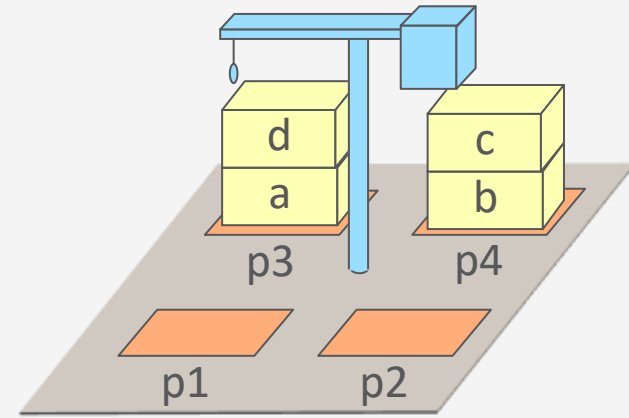

$z_4 \neq a$   
 $z_4 \neq c$   
 $z_4 \neq d$   
 satisfied

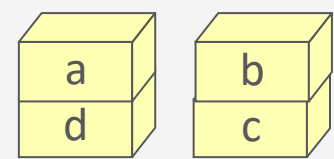
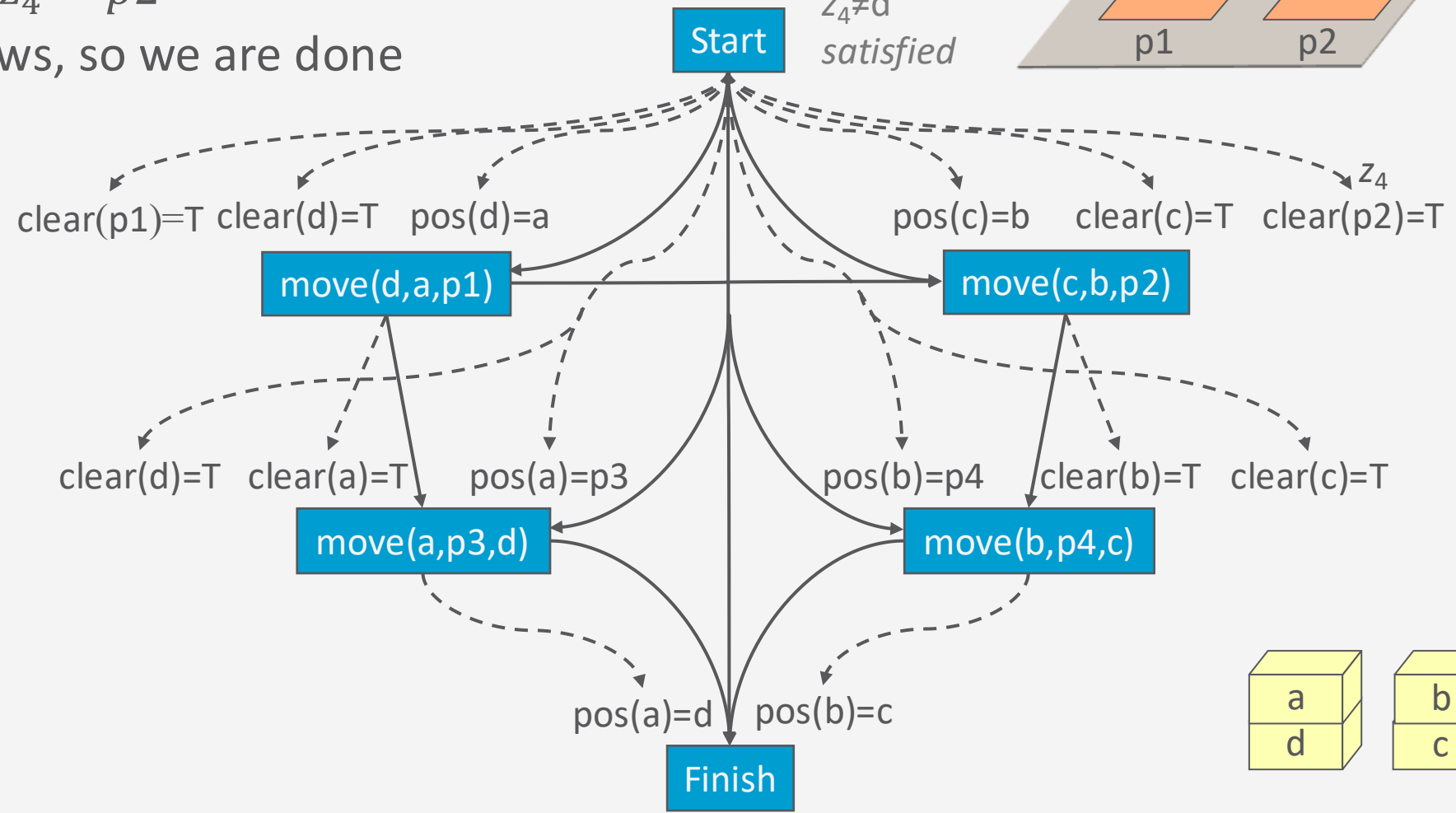

## Example 2

- Like previous solution, but has another ordering constraint

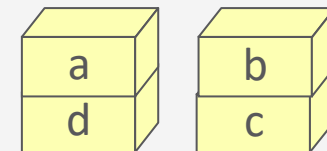
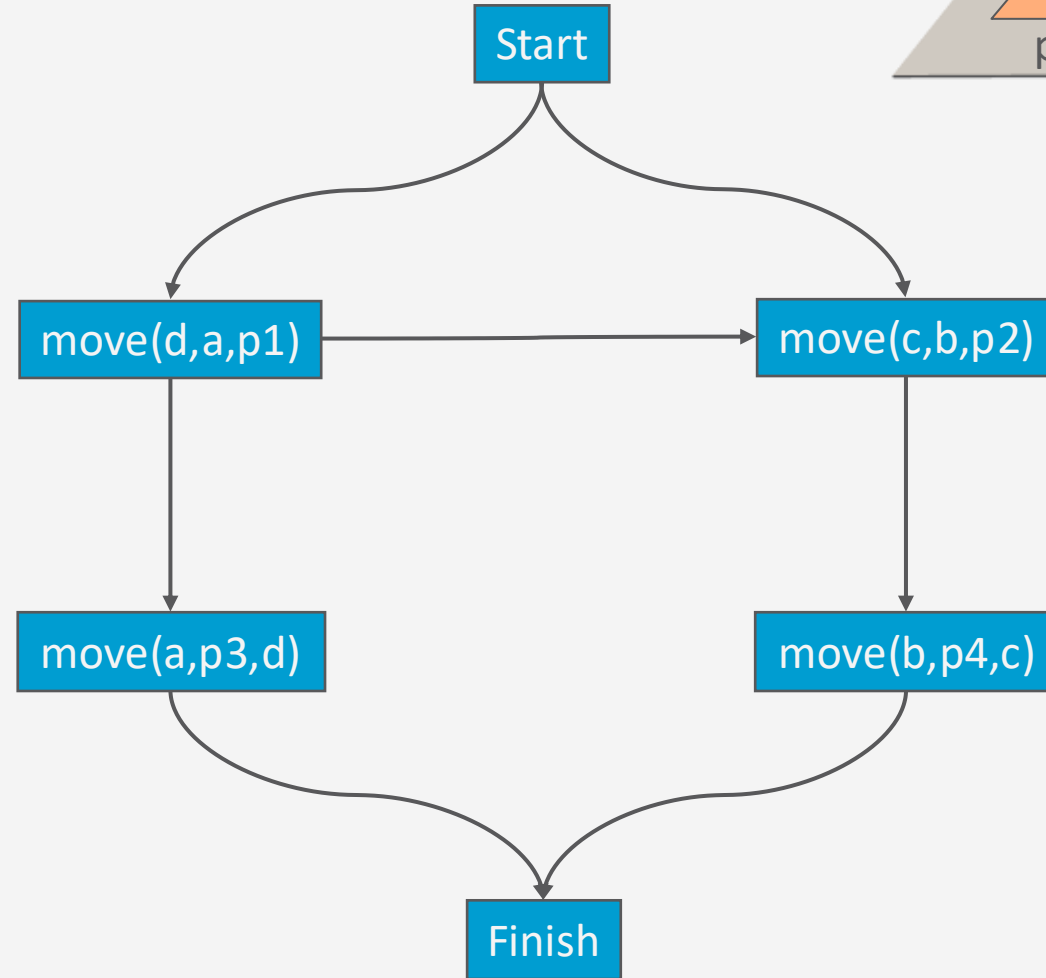
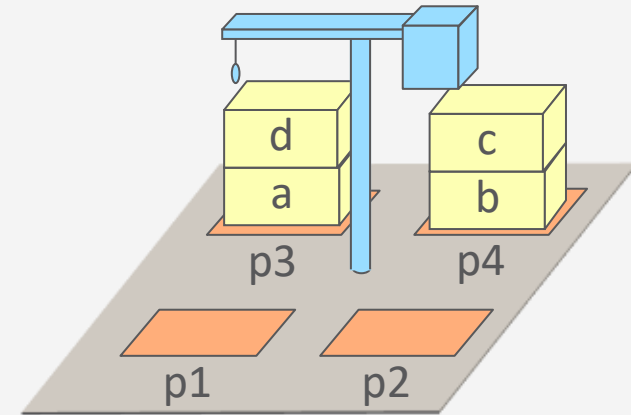

## Node-selection Heuristics

- Analogy to CSP
  - Resolving a flaw in PSP  
≈ assigning a value to a variable in a CSP
- What flaw to work on next?
  - **Fewest Alternatives First (FAF)**
    - Choose a flaw having the fewest resolvers  
≈ Minimum Remaining Values (MRV) heuristics for CSPs
- To resolve the flaw, which resolver to try first?
  - **Least Constraining Resolver (LCR)**
    - Choose a resolver that rules out the fewest resolvers for the other flaws  
≈ Least Constraining Value (LCV) heuristics for CSPs

# Example

- Fewest Alternatives First:
  - 1<sup>st</sup> threat has two resolvers: an ordering constraint, and  $z_4 \neq d$
  - 2<sup>nd</sup> threat has three resolvers: 2 ordering constraints, and  $z_4 \neq a$
  - 3<sup>rd</sup> threat has one resolver:  $z_4 \neq c$
- So, resolve the 3<sup>rd</sup> threat first

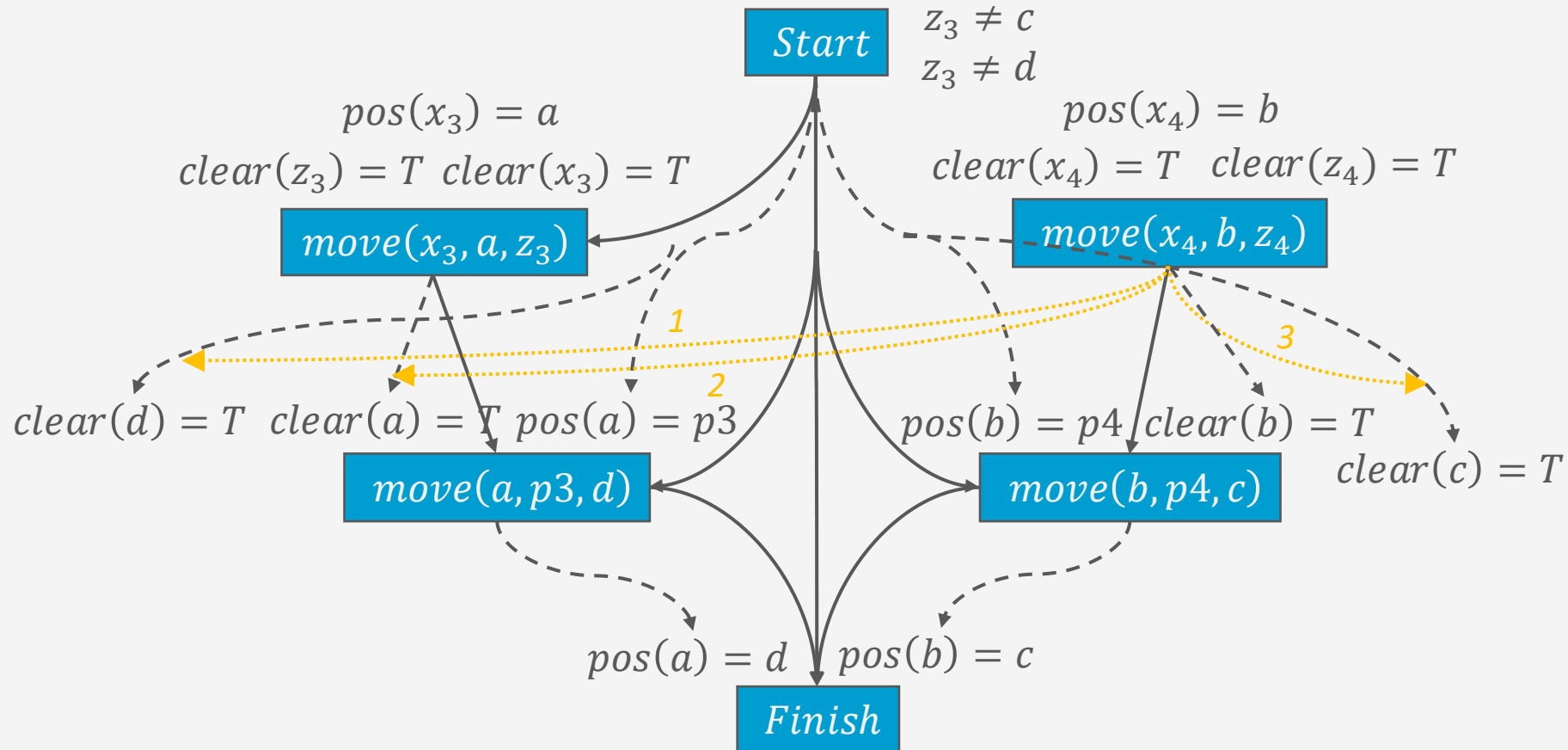

## Node-selection Heuristics

- In PSP, introducing a new action introduces new flaws to resolve
  - The plan can get arbitrarily large; want it to be as small as possible
    - Not like CSPs, where the search tree always has a fixed depth
  - Avoid introducing new actions unless necessary
- To choose between actions  $a$  and  $b$ , estimate distance from  $s_0$  to  $Pre(a)$  and  $Pre(b)$ 
  - Can use the heuristic functions we discussed earlier

## Discussion

- Problem: how to prune infinitely long paths in the search space?
  - Loop detection is based on recognizing states or goals we have seen before
  - In a partially ordered plan, we do not know the states
- Can we prune if  $\pi$  contains the same *action* more than once?
  - $\langle a_1, a_2, \dots, a_1, \dots \rangle$
  - No. Sometimes we might need the same action several times in different states of the world
  - E.g., Towers of Hanoi problem
    - Do this action many times:
      - stack disk1 onto disk2

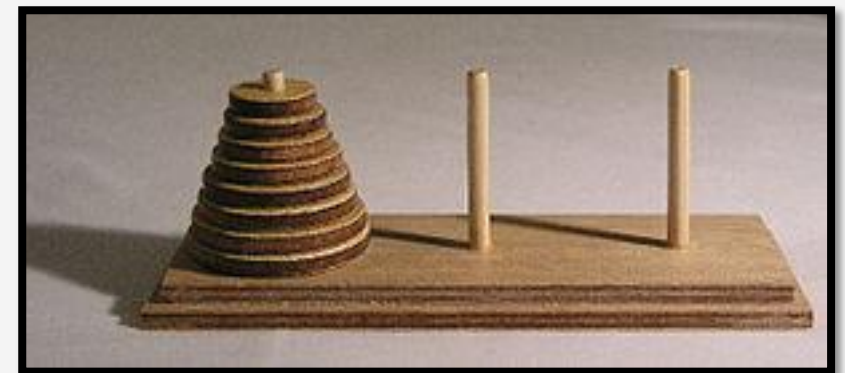

## A Weak Pruning Technique

- Can prune all partial plans of  $n$  or more actions, where  $n = |S|$ 
  - Not very helpful

*“I’m not sure whether there’s a good pruning technique for plan-space planning.”*

– Dana Nau

## Intermediate Summary

- Plan-space Search
  - Partially ordered plans and solutions
  - partial plans, causal links
  - flaws: open goals, threats, resolvers
  - PSP algorithm, long example, node-selection heuristics

## Summary

### 2.1 *State-variable representation*

- State = {values of variables}; action = changes to those values

### 2.2 *Forward state-space search*

- Start at initial state, look for sequence of actions that achieve goal

### 2.3 *Heuristic functions*

- How to guide a forward state-space search

### 2.6 *Incorporating planning into an actor*

- Online lookahead, unexpected events

### 2.4 *Backward search*

- Start at goal state, go backwards toward initial state

### 2.5 *Plan-space search*

- Start with incomplete plan for getting from initial state to goal state, make transformations to fix flaws in the plan

⇒ Next: Planning and Acting with Temporal Models