



WESTFÄLISCHE
WILHELMS-UNIVERSITÄT
MÜNSTER

From COSY to HESR: Mesons, Exotics and more...

GRK 2149 Annual Retreat 2015

24th – 26th November 2015



wissen.leben
WWU Münster

Alfons Khoukaz

Institut für Kernphysik



Meson Production and Decay Studies

- Investigation on meson production mechanisms
 - Elementary nucleon-nucleon scattering (e.g. $pp \rightarrow X$, $pn \rightarrow X$)
 - Fusion reactions (e.g. $pd \rightarrow {}^3\text{He}X$)
 - Mesons: e.g. π^0 , π^\pm , $\pi^+\pi^-$, η , η' , ω
- Study of the strong interaction between hadrons
 - Study of final state interactions between mesons and nucleons/nuclei (e.g. $d\eta$ or ${}^3\text{He}\eta$ systems)
- Symmetries and rare/forbidden η meson decays
- High precision measurements
 - E.g. η meson mass ($\Delta m/m = 5 \cdot 10^{-5}$)

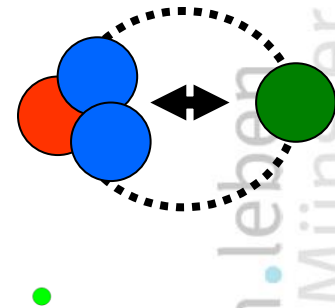
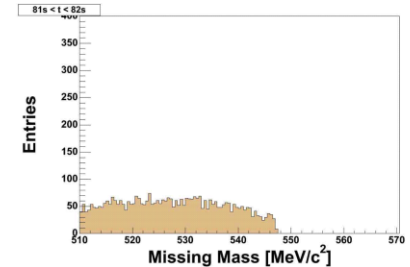



Targets for Accelerator Experiments

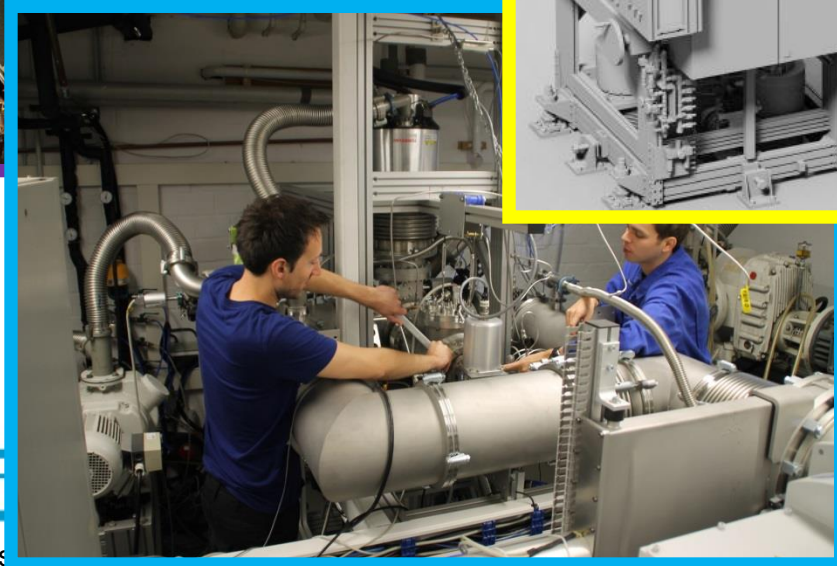
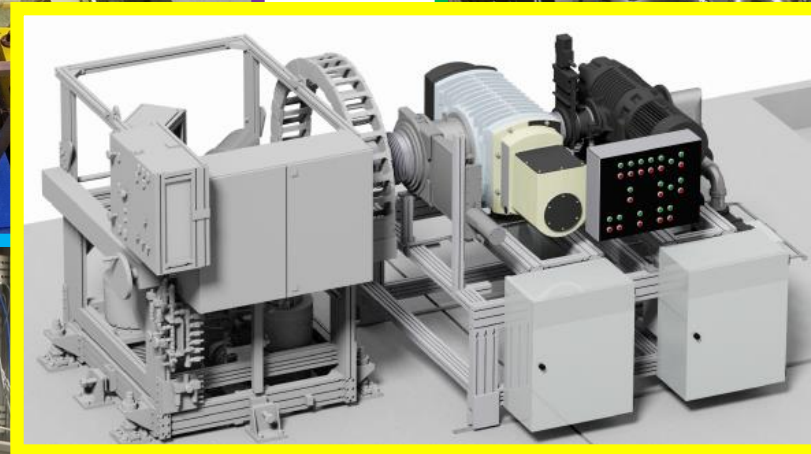
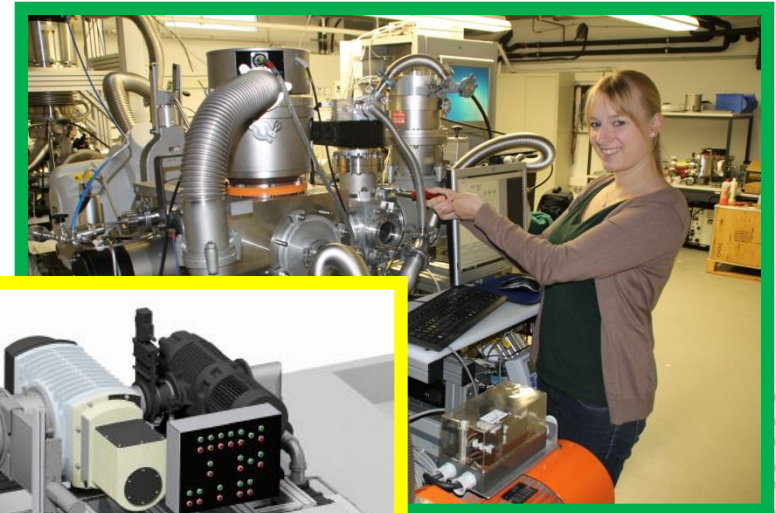
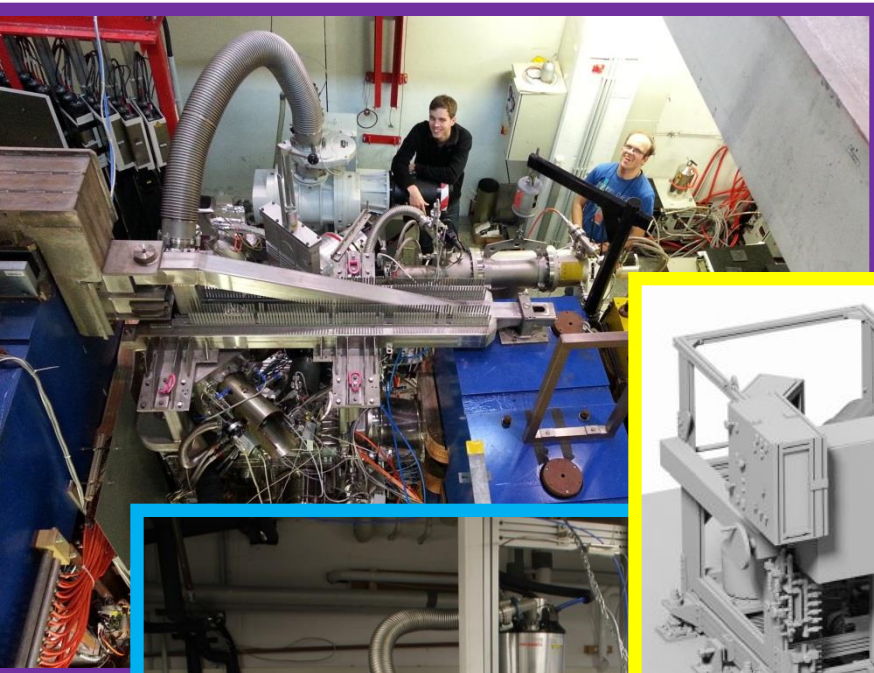

COSY Accelerator at Jülich



Energie range

- 0.045 – 2.8 GeV (p)
- 0.023 – 2.3 GeV (d)
(momentum 3.7 GeV/c)

Beam cooling

- Electron cooling
- Stochastic cooling

Polarisation

- p, d beams & targets

Accelerator beams

- intern, extern

„Our“ Experiments

- COSY-11, ANKE, WASA,

COSY (Cooler Synchrotron)



„Our“ Experiments at COSY

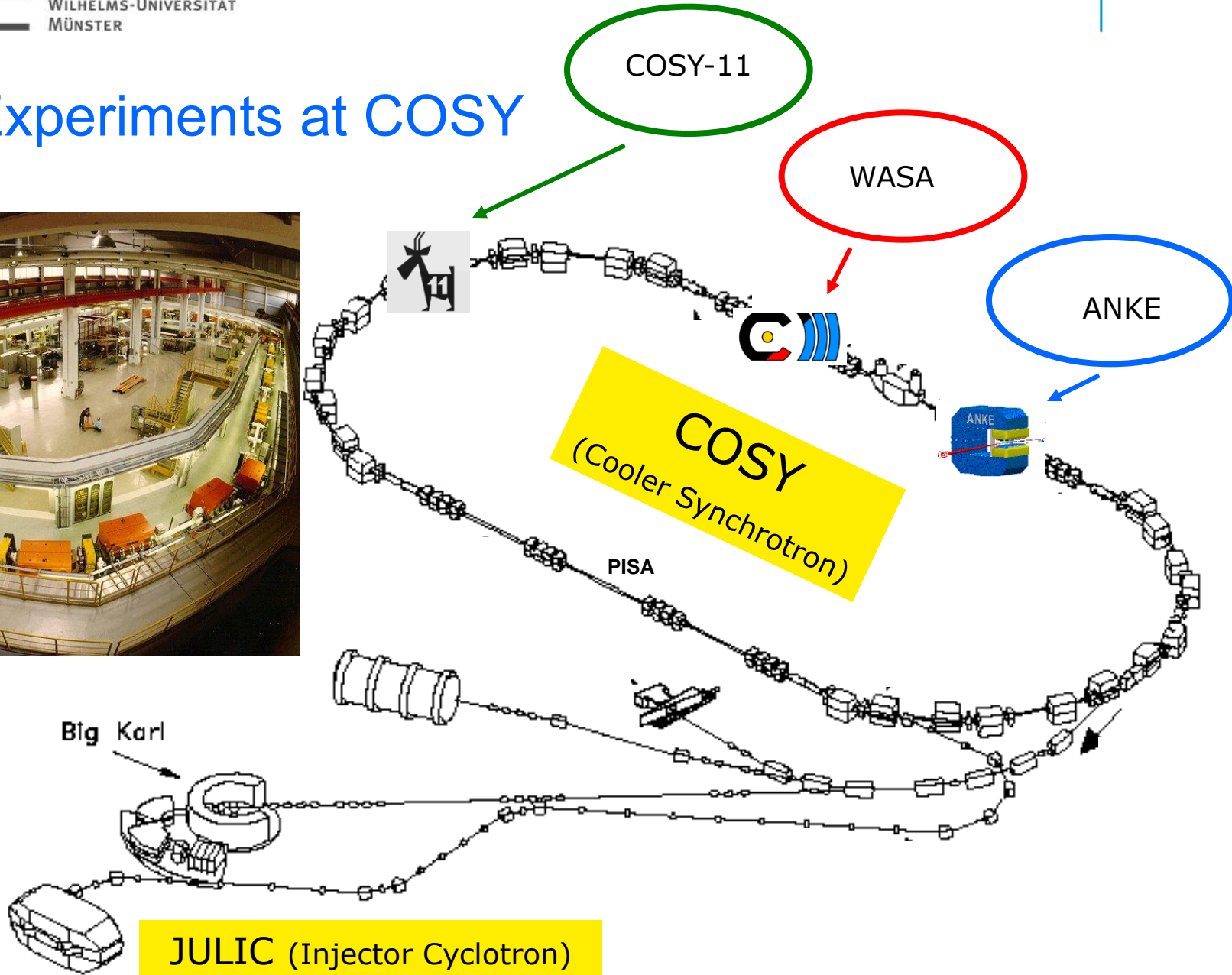

Meson Production and Decay Studies

- Investigation on meson production mechanisms
- Study of the strong interaction between hadrons
- Symmetries and rare/forbidden η meson decays
- High precision measurements

*~ 0.5 billion η
mesons on
tape*

- Huge set of COSY data available for detailed analyses
- Data are also highly interesting for preparatory studies for future experiments, e.g., PANDA at FAIR

From COSY to HESR/FAIR...

- The new FAIR facility will allow for a rich and exciting physics program with, e.g., anti-protons at HESR

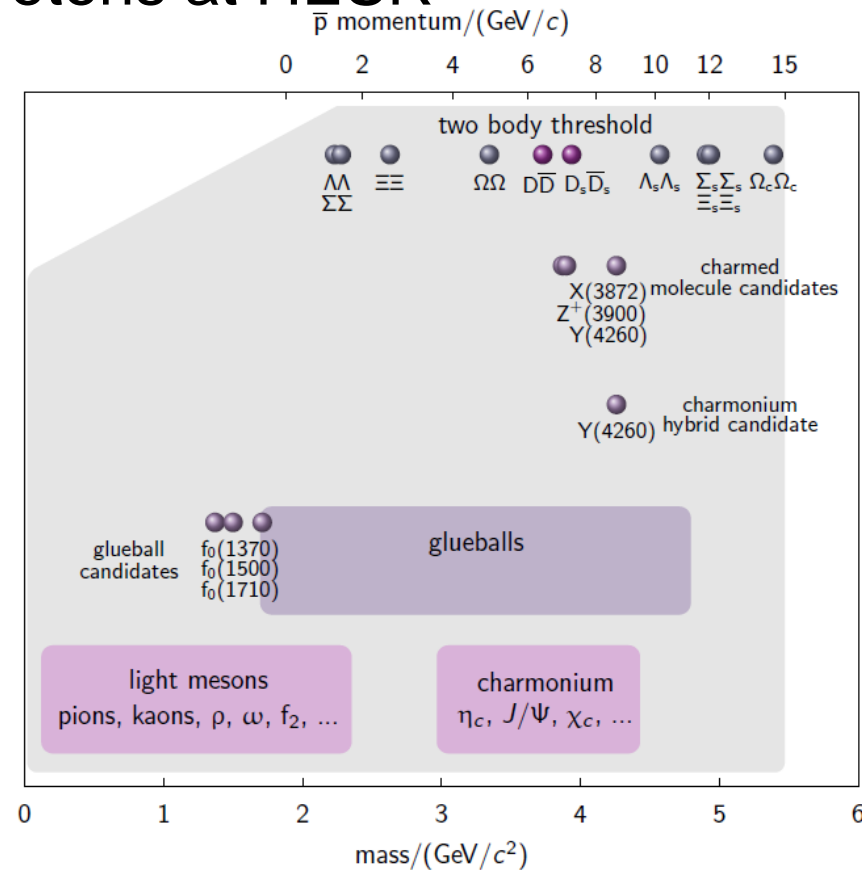
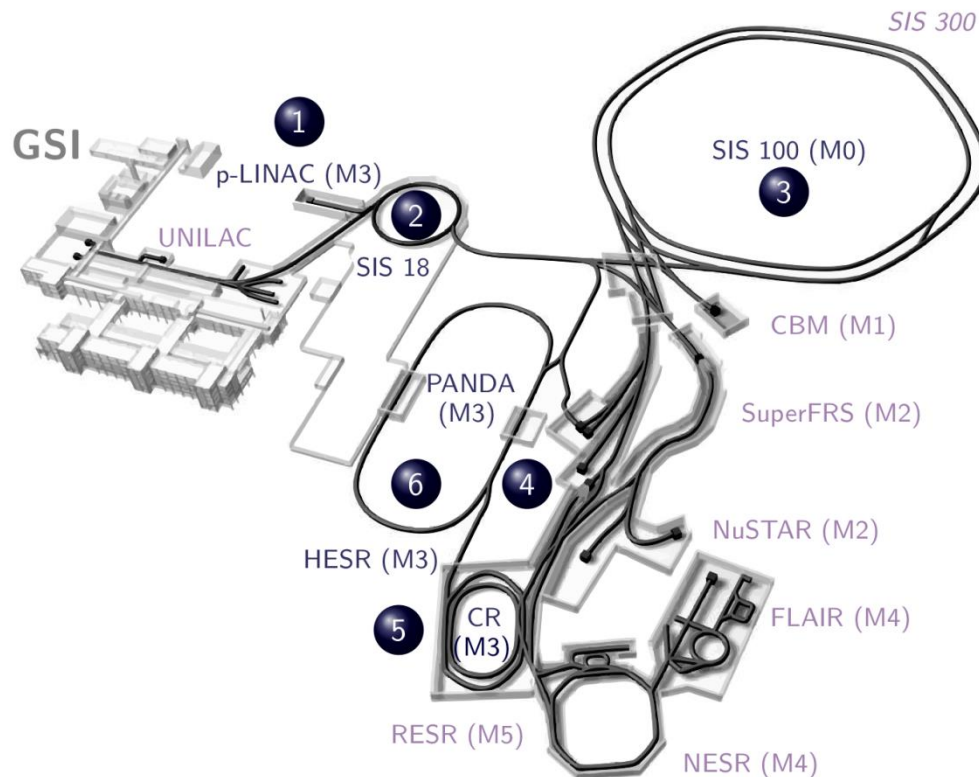

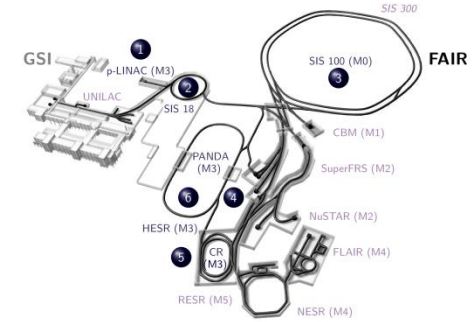

From COSY to HESR/FAIR...

- The new FAIR facility will allow for a rich and exciting physics program with, e.g., anti-protons at HESR
- PANDA Experiment:
 - Fixed target experiment for pbar-p and pbar-A interaction

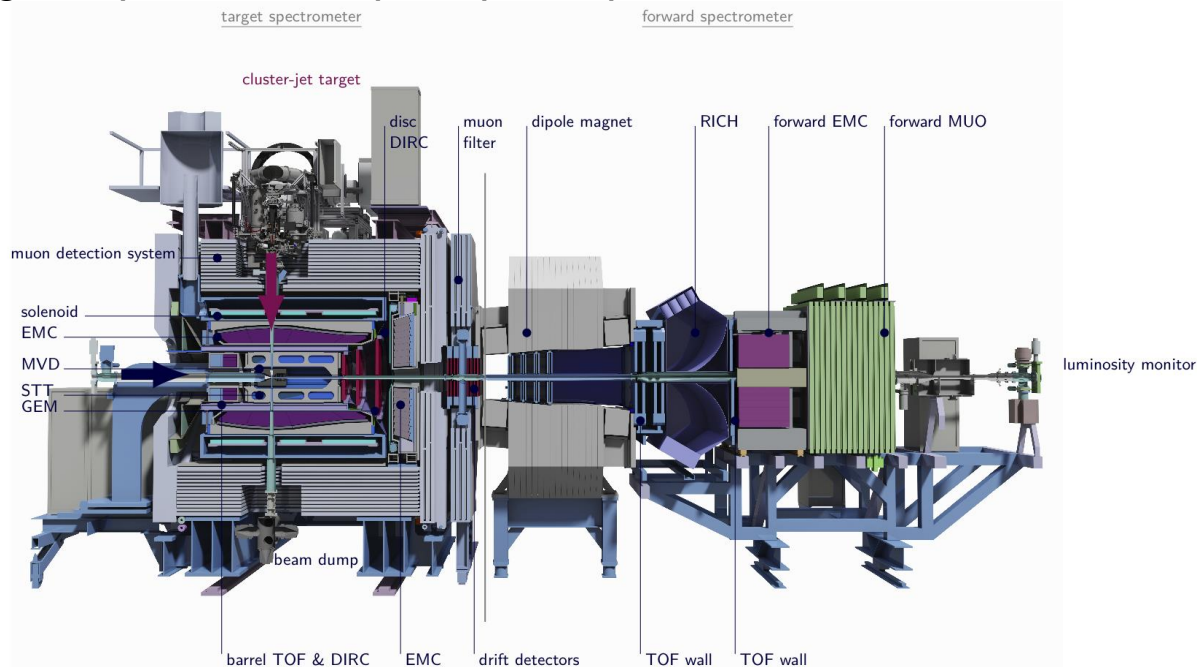

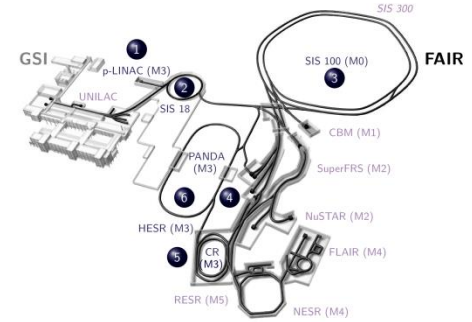

From COSY to HESR/FAIR...

- The new FAIR facility will allow for a rich and exciting physics program with, e.g., anti-protons at HESR
- PANDA Experiment:
 - Fixed target experiment for $p\bar{p}$ -p and $p\bar{p}$ -A interaction
 - Study of leptonic $D_{(s)}$ meson decays

A5+A6

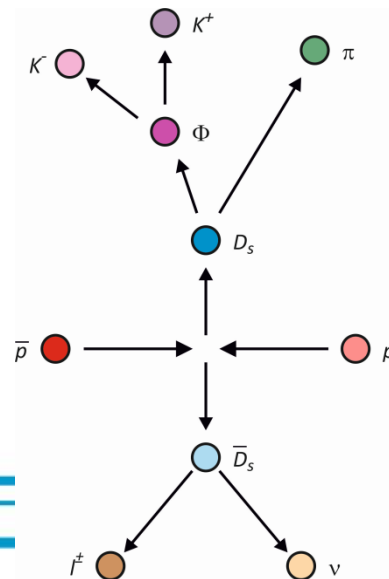
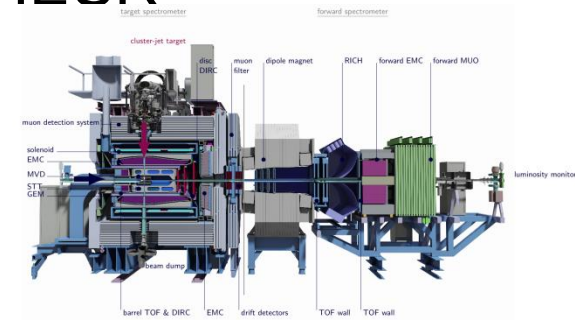

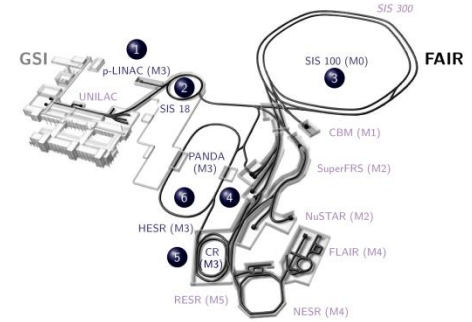

From COSY to HESR/FAIR...

- The new FAIR facility will allow for a rich and exciting physics program with, e.g., anti-protons at HESR
- PANDA Experiment:
 - Fixed target experiment for $p\bar{p}$ -p and $p\bar{p}$ -A interaction
 - Study of leptonic $D_{(S)}$ meson decays A5
 - Search/investigation of charmonium states
 - Search for exotic particles (glueballs, hybrids, ...)

A5+A6

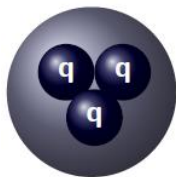
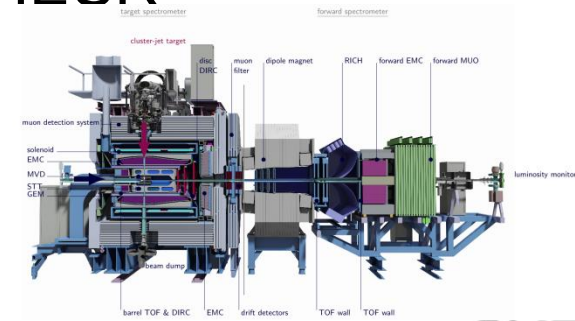

baryon

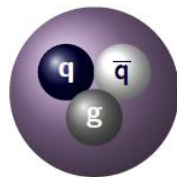

hybrid



glueball

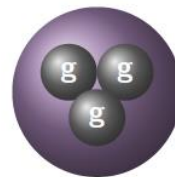

meson

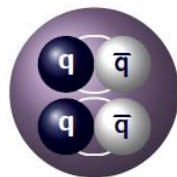

quark molecule



tetraquark



pentaquark

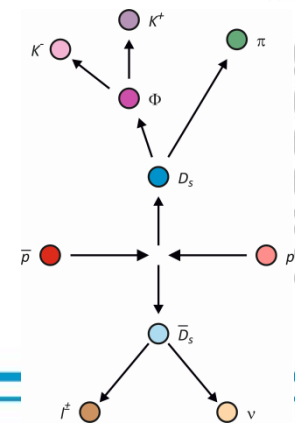

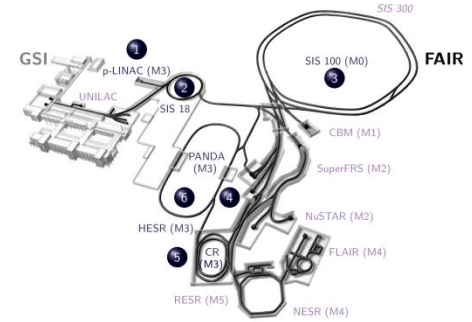

From COSY to HESR/FAIR...

- The new FAIR facility will allow for a rich and exciting physics program with, e.g., anti-protons at HESR
- PANDA Experiment:
 - Fixed target experiment for $p\bar{p}$ -p and $p\bar{p}$ -A interaction
 - Study of leptonic $D_{(S)}$ meson decays A5
 - Search/investigation of charmonium states
 - Search for exotic particles (glueballs, hybrids, ...)
 - Studies on (light?) X, Y, Z states

A5+A6

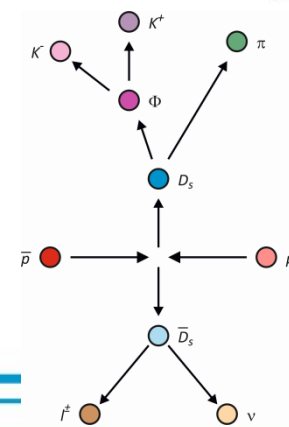
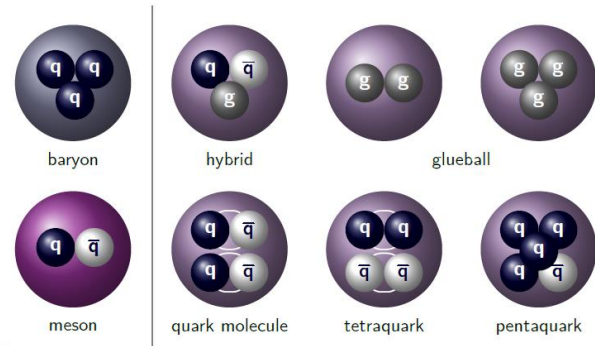
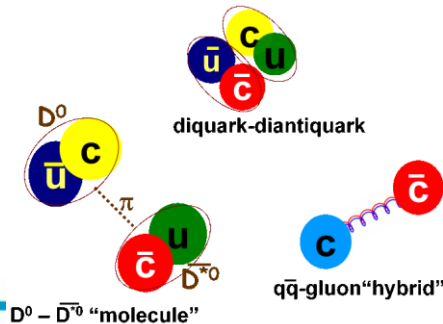
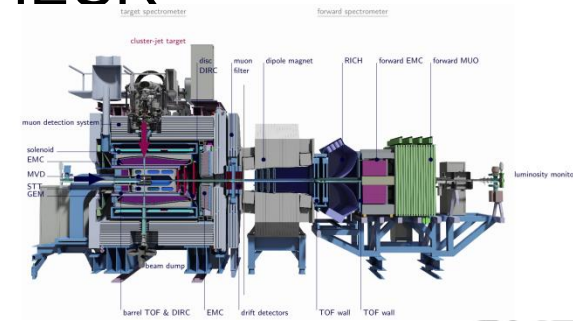

From COSY to HESR/FAIR...

- Simulation studies for future experiments (e.g. PANDA) can start right now
- Close cooperation with the AG Heitger
 - Leptonic $D_{(s)}$ meson decay studies
 - Exotic particles (e.g. glueballs, hybrids)
- Preparatory studies for future experiments strongly profit from current COSY analyses
- COSY experiments with their rich data sets and analysing/simulation tools provide nice experimental projects for 